



Jungheinrich Truck Terminal

WMT 215

Application

Jungheinrich Truck Terminals were specifically developed for heavy-duty use on forklift trucks and in logistics. In connection with the appropriate software solution, the terminals allow a significant increase of throughput, efficiency and quality of the logistics processes, whilst lowering operating costs at the same time. Thanks to the fanless design with maintenance-free and shock-resistant components plus cold store capability to -30°C , these terminals offer reliable service in any environment.

Software

For optimum compatibility protection against software manipulation, the terminals are equipped with a lean, optionally write-protected Windows® 10 IoT Enterprise operating system. Jungheinrich offers the possibility of defining customer-specific software versions and settings so the devices can be used immediately "out of the box".

Features and interfaces

The terminal offers a variety of equipment options and accessories for industrial applications. Fitted with a solid-state drive (SSD) with up to 192 GB, 8 GB RAM and the latest Windows operating system, even CPU intensive applications run smoothly. Two integrated antennas ensure an optimal WLAN connection at all times and also support the current Wi-Fi 6 standard. Numerous standardized interfaces such as USB, RS-232 and Bluetooth meet all your requirements.

Power supply and optional battery (UPS)

Thanks to the optimal adapted power supply of 12 to 48 volts, the terminals can be supplied directly via the truck's board voltage without a converter. An optionally available battery bridges voltage interruptions or short pauses.

Service and support

We provide all the support regarding the proper assembly and commissioning of the devices in your work environment. With service and support executed by Jungheinrich, you benefit from maximum availability and optimum performance of your devices.

Everything from a single source

The truck terminals from Jungheinrich receive transport orders via the radio network directly from the warehouse management system and provide the employees with the required information directly at the truck.

Thanks to the holistic product portfolio, Jungheinrich offers you all the components needed for more productivity in the warehouse - from the digitalization and automation of individual processes to in-house warehouse management systems and fully integrated IT solutions from a single source.

WMT 215

Without USV

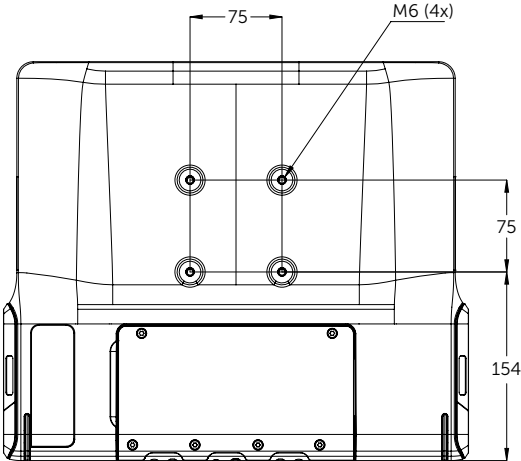
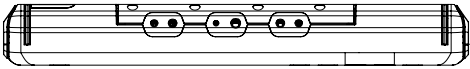
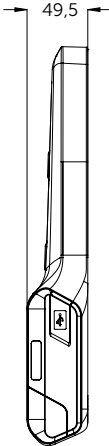
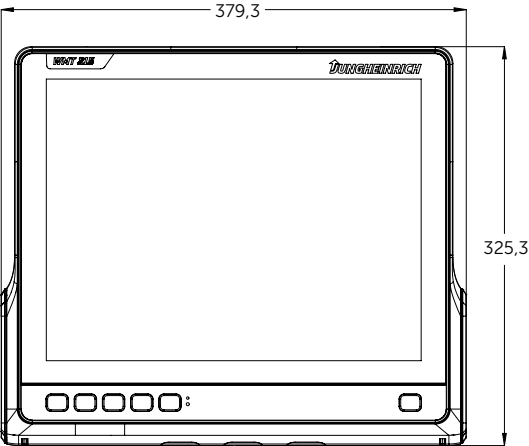

With USV

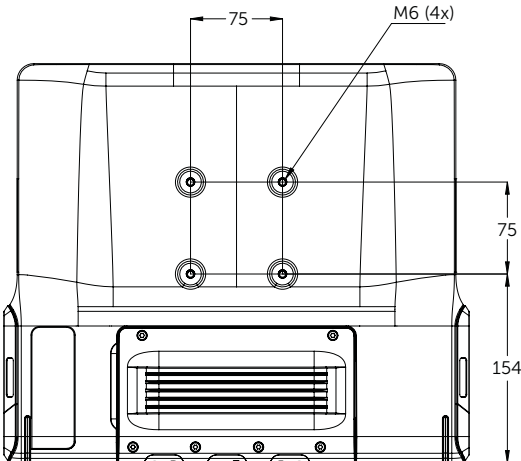
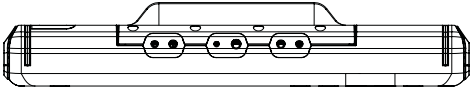
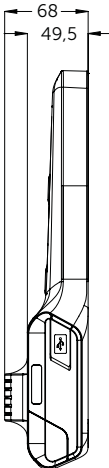
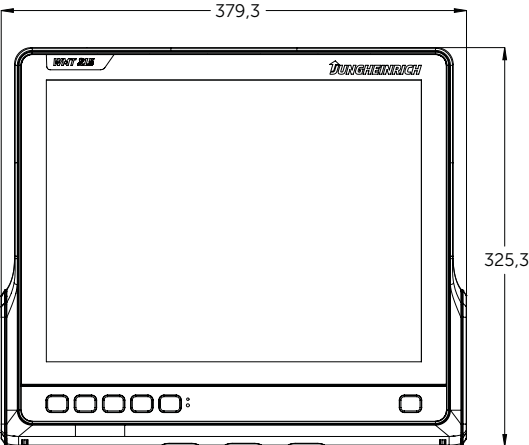



		WMT 215
Display and housing	Housing (W x H x D)	380 x 326 x 50 mm – 4.6 kg
	Housing with USV (W x H x D)	380 x 326 x 68 mm – 4.7 kg incl. USV
	Display	15", XGA 1024 x 768 Pixel, Typ. 500 cd/m ²
	Vibration/shock	Vibration 3 G (EN 60068-2-6) Schock 40 G (EN 60068-2-27)
	Protection rating	IP 65
	Assembly preparation	VESA 75 – hole pattern on rear and optional mounting bracket
	Operating environment	–30 °C to +50 °C, rel. humidity permanently at 95 %, non-condensing
	Storage temperature	–40 °C to +80 °C
	Power supply	12–48 V DC (9 to 72 V DC)
	Power consumption	Typically 25 W, max. 50 W, 64 W incl. USV
	Battery – UPS	Optional: for operation for min. 15 minutes and controlled shutdown
Architecture	Processor	Intel Atom x7-E3950 (Quad-Core-SoC, up to 2 GHz)
	RAM	8 GB LPDDR4 RAM
	Mass storage	64 GB eMMC (MLC) – optional: additional 128 GB mSATA industrial SSD
	Audio	Integrated stereo loudspeakers
Operation and interfaces	Touchscreen	Resistive
	Front buttons	4 freely programmable front buttons, double assignment via additional FN button
	WLAN	Wi-Fi 6 (2,4 and 5 GHz) via 2 internal antennas – 1 x R-SMA connector
	Bluetooth	Bluetooth 5.2
	LAN	2 x Ethernet 10/100/1000 Mbit RJ45
	USB	3 x TYP A USB 3.0 in the service duct, 1 x TYP A USB 2.0 in the front area, All external USB ports offer a high current of 1A
	RS-232	2 x D-Sub 9-pin, 1 x 5 V DC connectible to PIN 9
Software	Operating System	Windows 10 IoT Enterprise 2021 LTSC
	Software	Configurable on-screen keyboard, write-protection filter, tool for connecting serial scanners, tool for backup and recovery
Accessories and support	Accessories	Installation Guide, DC connector terminal Optional: desktop power supply (230 V AC), scanner holder, keyboard and keyboard holder, mounting bracket, dc-connection cable
	Warranty/Support	12 months liability for defects Optional: up to 5 years comprehensive coverage

Windows is a trademark or a registered trademark of the Microsoft Corporation in the USA and/or other countries. Intel and Atom are trademarks or registered trademarks of the Intel Corporation and its subsidiaries in the USA and/or other countries. Rights reserved for technical alterations and improvements.

Jungheinrich Aktiengesellschaft

Friedrich-Ebert-Damm 129
22047 Hamburg
Germany
Telephone +49 40 6948-0
Telefax +49 40 6948-1777

info@jungheinrich.com
www.jungheinrich.com

The German production facilities
in Norderstedt, Moosburg
and Landsberg are certified. **ISO 9001**
ISO 14001

Jungheinrich trucks
conform to the European
Safety Requirements. 