

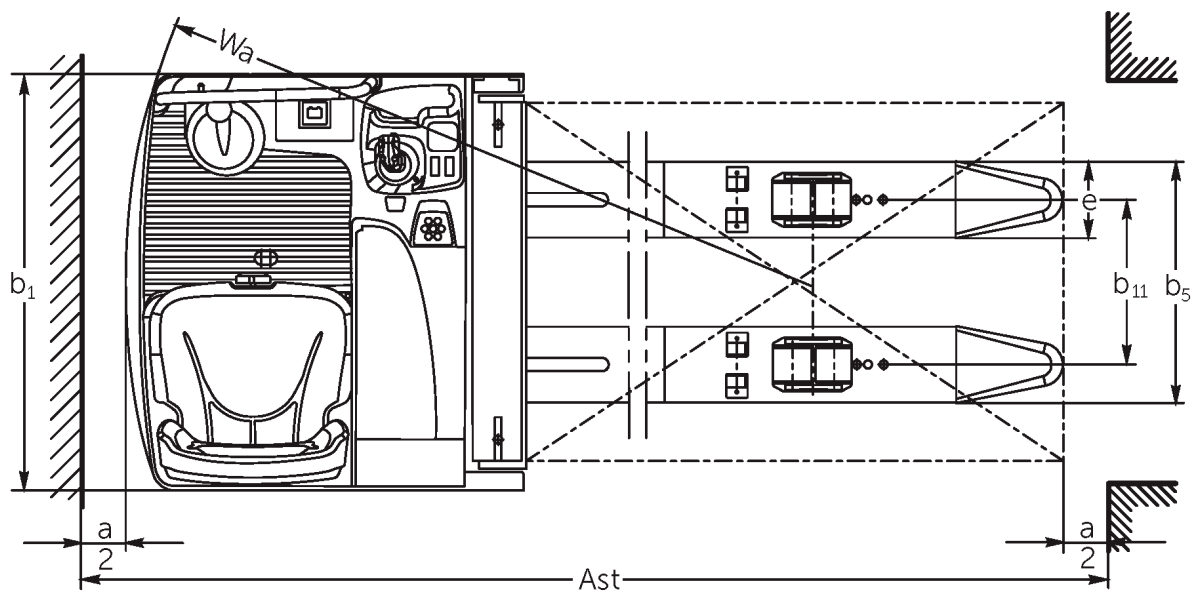

## **Electric sideways-seated pallet truck** **ESE 220-320**

**Lift height: 125 mm / Load capacity: 2000 kg**

# ESE 220-320

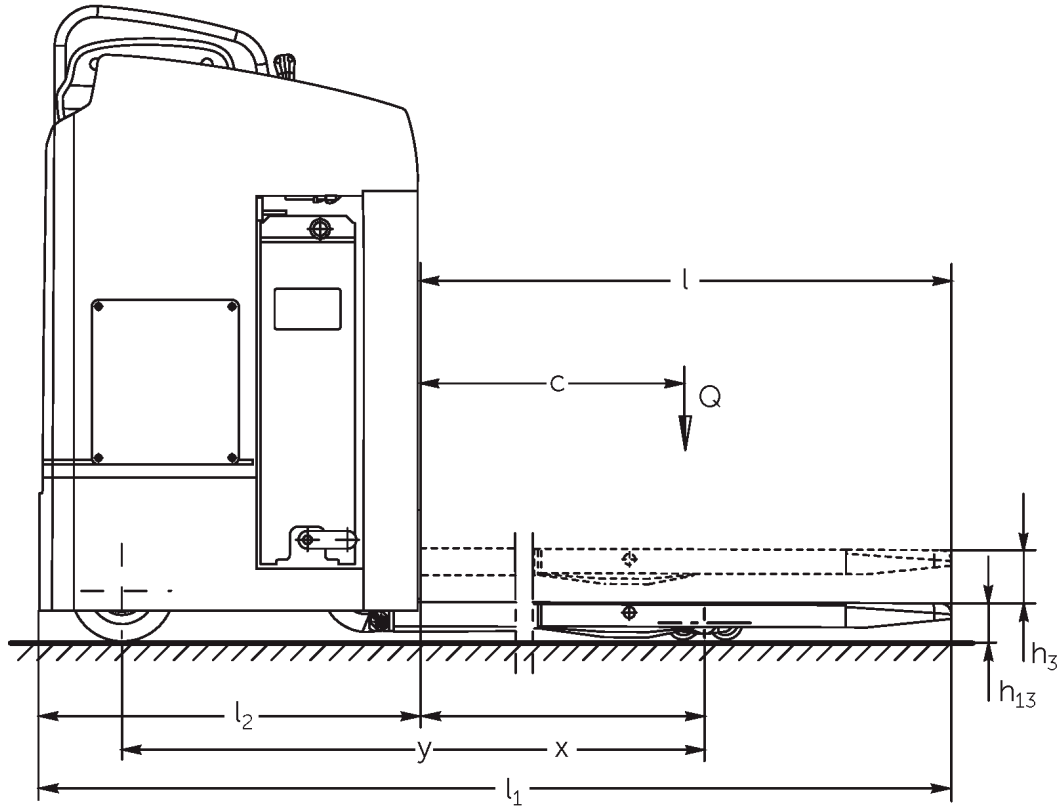

# VDI table

Stand-on: 04/2022

Characteristic	Item No.	Description	Unit	Jungheinrich		
				ESE 220	ESE 320	
Characteristic	1.1	Manufacturer (abbreviated description)		Jungheinrich		
	1.2	Manufacturer's type designation		ESE 220	ESE 320	
	1.3	Drive		Electric		
	1.4	Operation		Seat		
	1.5	Load capacity/load	Q	kg	2000	
	1.6	Load centre distance	c	mm	600	
	1.8	Load distance, centre of drive axle to fork	x	mm	868	
	1.9	Wheelbase	y	mm	1535	1541
	Weights	2.1.1	Service weight (incl. battery)		kg	1062
2.2		Axle load laden front/rear		kg	1896 / 1142	1902 / 1182
2.3		Axle load unladen front/rear		kg	258 / 808	264 / 816
Wheels/suspension system	3.1	Tyres		Polyurethane (PU)		
	3.2	Tyre size, front		Ø 230 x 78		
	3.3	Tyre size, rear		Ø 85x85		
	3.4	Additional wheels		Ø 140 x 54		
	3.5	Wheels, number front/back (x=driven)		2 - 1x / 4	1+1x/4	
	3.6	Tread width, front	b <sub>10</sub>	mm	544	645
	3.7	Tread width, rear	b <sub>11</sub>	mm	385	
Basic dimensions	4.4	Lift (h <sub>3</sub> )	h <sub>3</sub>	mm	125	
	4.8	Seat height/stand height	h <sub>7</sub>	mm	1020	
	4.15	Height, lowered	h <sub>13</sub>	mm	90	
	4.19	Overall length	l <sub>1</sub>	mm	2009	
	4.20	Length including fork shank	l <sub>2</sub>	mm	859	
	4.21.1	Overall width	b <sub>1</sub>	mm	820	930
	4.22	Fork dimensions	s/e/l	mm	60 x 172 x 1150	
	4.25	Width across forks	b <sub>5</sub>	mm	540	
	4.32	Ground clearance centre of wheelbase	m <sub>2</sub>	mm	25	
	4.34.1	Aisle width (pallet 800x1200 length)	Ast	mm	2197	2215
	4.35	Turning radius	W <sub>a</sub>	mm	1665	1683
Performance data	5.1	Travel speed laden/unladen		km/h	10 / 12.5	
	5.2	Lift speed laden/unladen		m/s	0.06 / 0.07	
	5.3	Lowering speed laden/unladen		m/s	0.06 / 0.05	
	5.8	Max. gradeability laden/unladen		%	8 / 13	
	5.10	Service brake			electric	
E-motor/Electronics	6.1	Drive motor, performance S2 60 min		kW	2.8	
	6.2	Lift motor, performance with S3		kW	1.5	
	6.3	Battery according to DIN 43531/35/36			no	
	6.4	Battery voltage/nominal capacity		V / Ah	24 / 465	
	6.5	Battery weight		kg	380	
	6.6.1	Energy consumption according to EN cycle		kWh/h	0.41	0.43
	6.6.2	CO2 equivalent as per EN 16796		kg/h	0.2	
Other	8.1	Type of drive control			AC	

- This data sheet according to VDI guideline 2198 only states the technical values of the standard truck. Different tyres, other masts, additional equipment etc. may result in different values.

- VDI no. 1.8: lowered load section: + 90 mm.
- VDI no. 1.9: lowered load section: ESE 220: + 90 mm, ESE 320: + 95 mm.
- VDI no. 4.34: diagonal as per VDI: + 188 mm.

The German production facilities in  
Norderstedt, Moosburg and Landsberg  
are certified.

ISO 9001  
ISO 14001

Jungheinrich fork lift trucks meet  
European safety requirements.



 **JUNGHEINRICH**

The Jungheinrich logo, featuring a red upward-pointing arrow integrated into the letter 'J', followed by the brand name 'JUNGHEINRICH' in a bold, black, sans-serif font.