

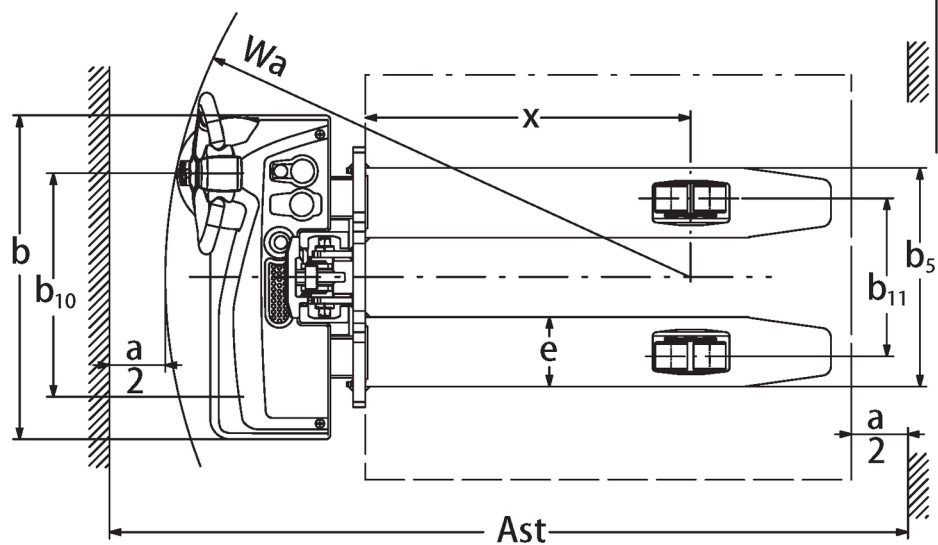

## **Electric pedestrian stacker** **EJC M10 E / M10b E**

**Lift height: 1540-1900 mm / Load capacity: 1000 kg**

# EJC M10 E / M10b E

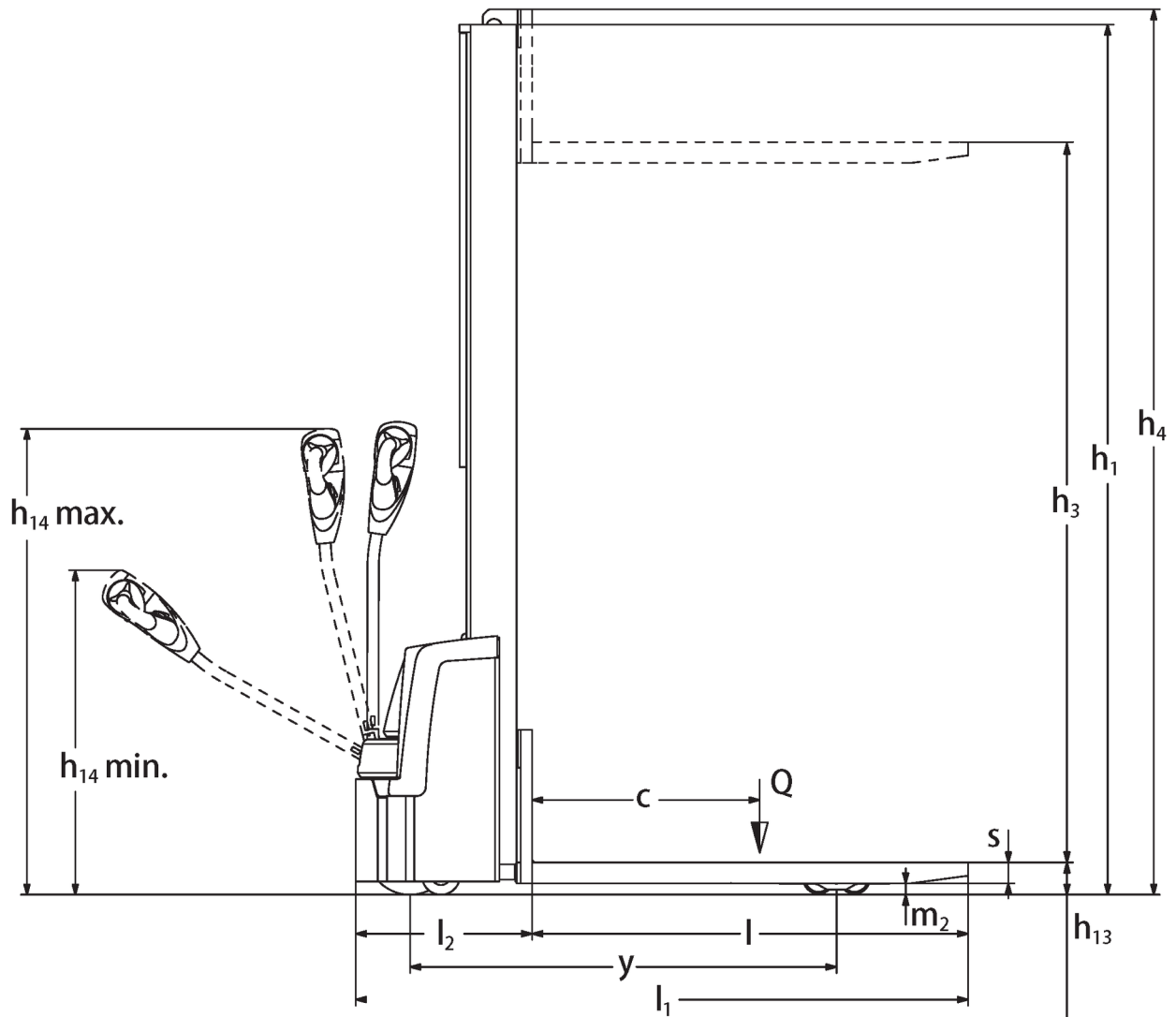

EJC M10 (E)

# EJC M10 E / M10b E

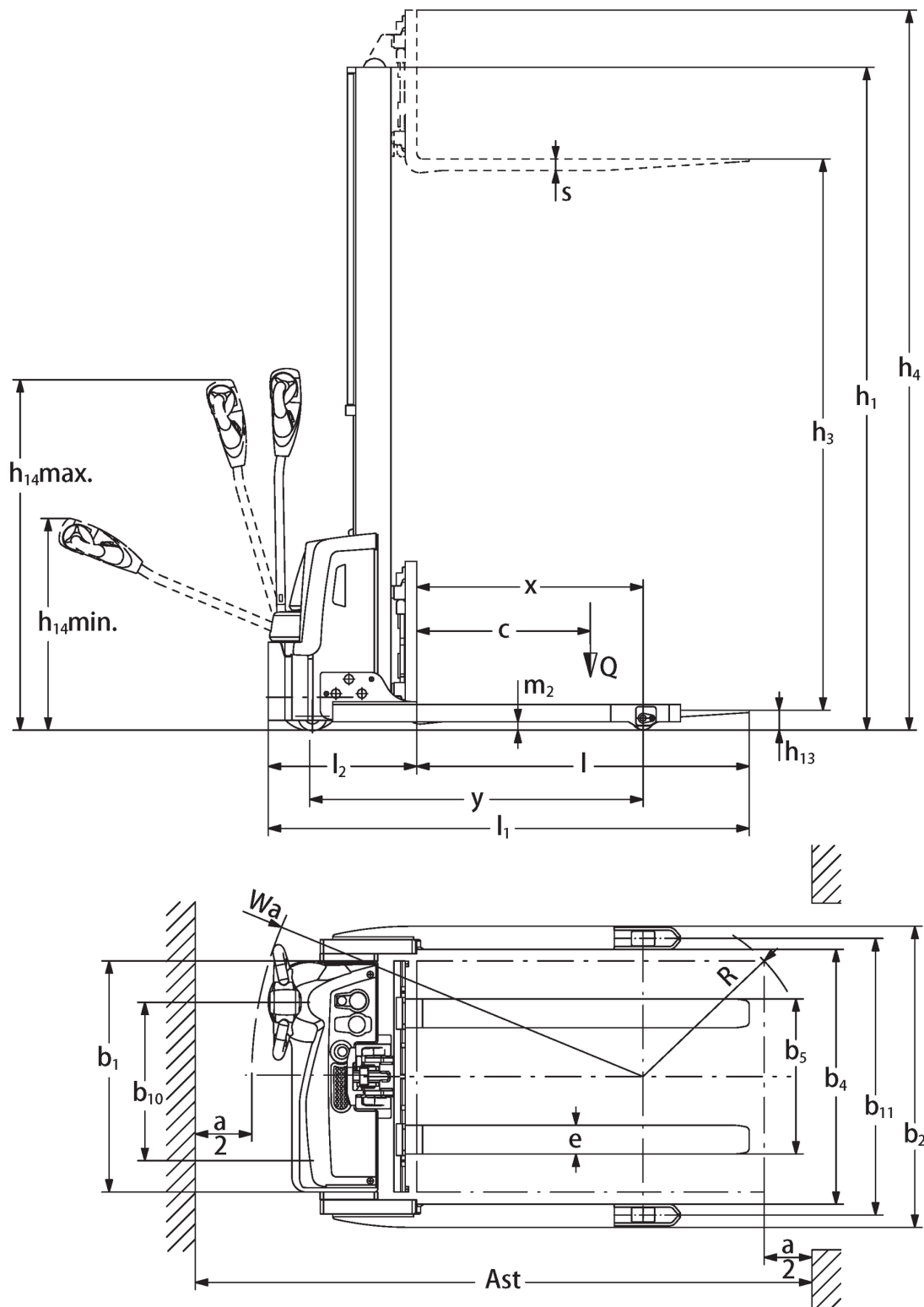

# VDI table

Stand-on: 12/2022

			Jungheinrich				
			EJC M10 E 1540 Li-Ion	EJC M10 E 1900 Li-Ion	EJC M10b E 1540 Li-Ion	EJC M10b E 1900 Li-Ion	
Kennzeichen	1.1	Manufacturer (abbreviated description)					
	1.2	Manufacturer's type designation					
	1.3	Drive	Electric				
	1.4	Operation	Pedestrian				
	1.5	Load capacity/load	Q kg	1000			
	1.6	Load centre distance	c mm	600			
	1.8	Load distance, centre of drive axle to fork	x mm	803		783	
	1.9	Wheelbase	y mm	1125		1154	
	Gewichte	2.1.1	Service weight (incl. battery)	kg	460	478	602
2.2		Axle load laden front/rear	kg	622 / 838	630 / 848	560 / 1042	570 / 1050
2.3		Axle load unladen front/rear	kg	350 / 110	360 / 118	430 / 172	440 / 180
Räder/Fahrwerk	3.1	Tyres	TPU/PU		Polyurethane (PU)		
	3.2	Tyre size, front	Ø230x65				
	3.3	Tyre size, rear	Ø80x70		Ø100x50		
	3.4	Additional wheels	Ø100x50		Ø80x50		
	3.5	Wheels, number front/back (x=driven)	1x+1/4		1x+1/2		
	3.6	Tread width, front	b <sub>10</sub> mm	550			
	3.7	Tread width, rear	b <sub>11</sub> mm	390		962	
	3.7.1	2. Tread width, rear	mm	-		1128	
	3.7.2	3. Tread width, rear	mm	-		1328	
Grundabmessungen	4.2	Retracted mast height (h1)	h <sub>1</sub> mm	1935	2295	1935	2295
	4.3	Free lift (h2)	h <sub>2</sub> mm	1500	1860	1350	1710
	4.4	Lift (h3)	h <sub>3</sub> mm	1540	1900	1540	1900
	4.5	Extended mast height (h4)	h <sub>4</sub> mm	1975	2335	2125	2485
	4.9	Height of tiller handle in drive position min./max.	mm	740 / 1190			
	4.15	Height, lowered	h <sub>13</sub> mm	85			
	4.19	Overall length	l <sub>1</sub> mm	1615		1664	
	4.20	Length including fork shank	l <sub>2</sub> mm	465		514	
	4.21.1	Overall width	b <sub>1</sub> mm	800			
	4.21.2	Overall width	b <sub>2</sub> mm	800		1042	
	4.22	Fork dimensions	s/ e/l mm	55 x 172 x 1150		40 x 100 x 1150	
	4.25	Width across forks	b <sub>5</sub> mm	540		316	
	4.26	Width between support arms/loading areas	b <sub>4</sub> mm	-		882	
	4.32	Ground clearance centre of wheelbase	m <sub>2</sub> mm	30		35	
	4.34.1	Aisle width (pallet 1000x1200 sideways)	Ast mm	2127		2163	
	4.34.2	Aisle width (pallet 800x1200 length)	Ast mm	2059		2100	
	4.35	Turning radius	W <sub>a</sub> mm	1295		1325	
Leistungsdaten	5.1	Travel speed laden/unladen	km/h	4.5 / 5			
	5.2	Lift speed laden/unladen	m/s	0.12 / 0.22			
	5.3	Lowering speed laden/unladen	m/s	0.15 / 0.12			
	5.8	Max. gradeability laden/unladen	%	4 / 10			
	5.10	Service brake		electric			

E-Motor/Elektronik	6.1	Drive motor, performance S2 60 min	kW	0.6
	6.2	Lift motor, performance with S3	kW	2.2
	6.3	Battery according to DIN 43531/35/36		no
	6.4	Battery voltage/nominal capacity	V / Ah	25.6 / 50
	6.5	Battery weight	kg	15
	6.6.1	Energy consumption according to EN cycle	kWh/h	0.73
	6.6.2	CO2 equivalent as per EN 16796	kg/h	0.4
Sonstiges	8.1	Type of drive control		AC
	10.7	Sound level as per EN12053, operator's ear	dB (A)	66

- This data sheet according to VDI guideline 2198 only states the technical values of the standard truck. Different tyres, other masts, additional equipment etc. may result in different values.

The German production facilities in  
Norderstedt, Moosburg and Landsberg  
are certified.

ISO 9001  
ISO 14001

Jungheinrich fork lift trucks meet  
European safety requirements.



 **JUNGHEINRICH**