

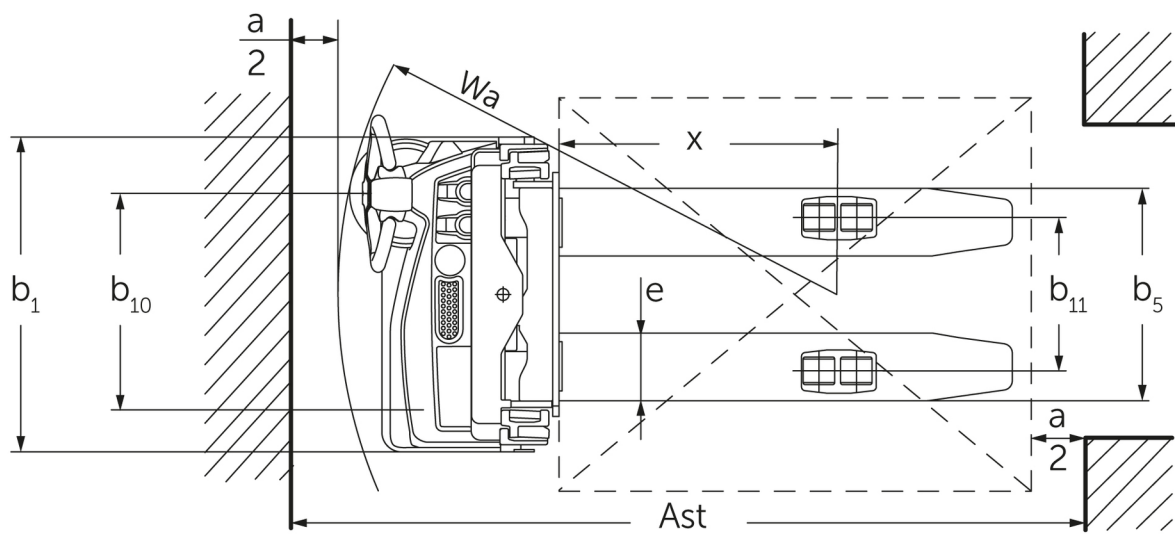

Electric pedestrian stacker **EJC M10 ZT / M13 ZT**

Lift height: 2300-3300 mm / Load capacity: 1000-1300 kg

EJC M10 ZT / M13 ZT

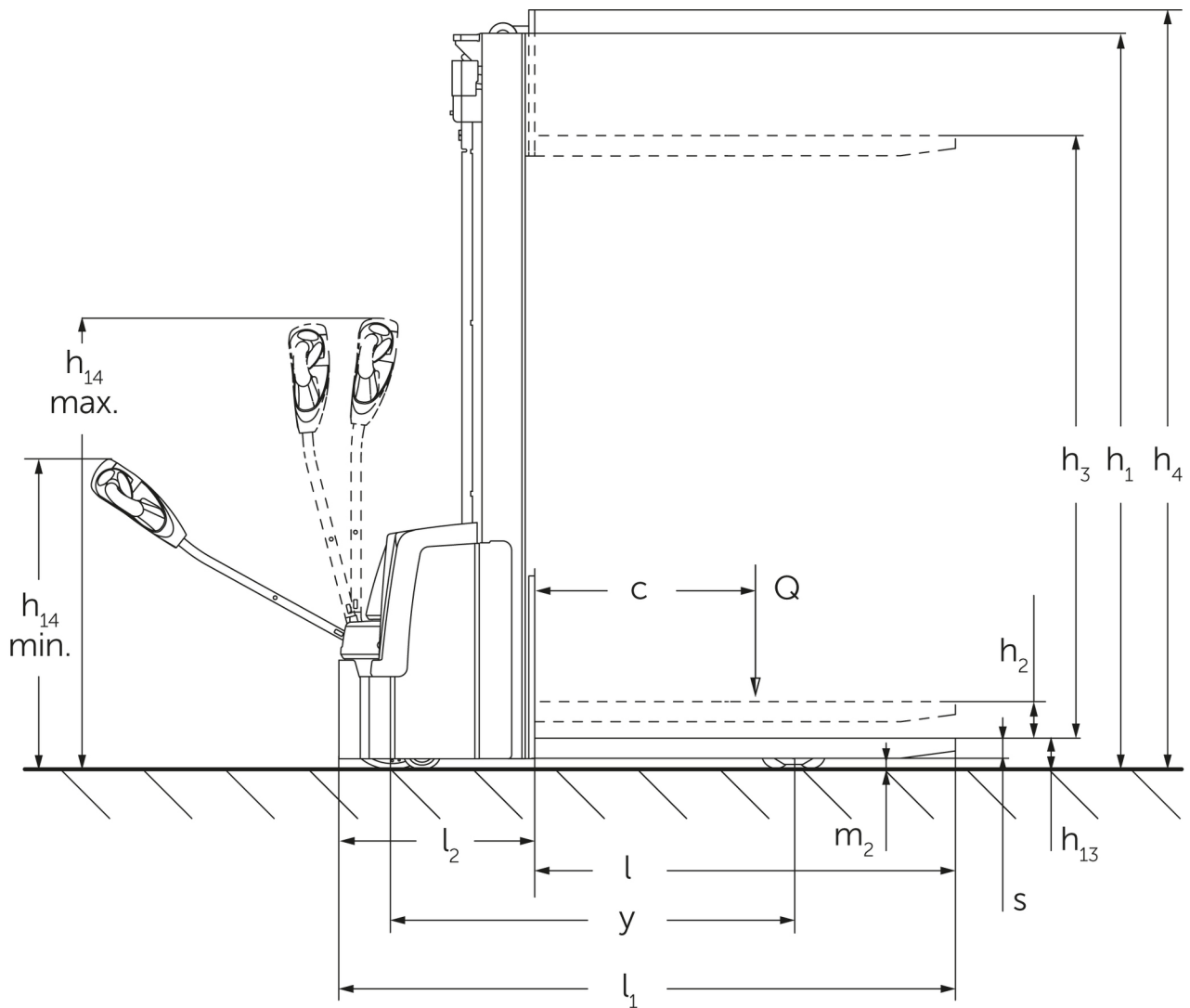

VDI table

Stand-on: 01/2023

Kennzeichen	1.1	Manufacturer (abbreviated description)		Jungheinrich							
	1.2	Manufacturer's type designation		EJC M10 ZT 2300 Li-Ion	EJC M10 ZT 2500 Li-Ion	EJC M10 ZT 2900 Li-Ion	EJC M10 ZT 3300 Li-Ion	EJC M13 ZT			
	1.3	Drive		Electric							
	1.4	Operation		Pedestrian							
	1.5	Load capacity/load	Q kg	1000				1300			
	1.6	Load centre distance	c mm	600							
	1.8	Load distance, centre of drive axle to fork	x mm	710							
	1.9	Wheelbase	y mm	1098				1296			
	Gewichte	2.1.1	Service weight (incl. battery)	kg	551	560	578	596	695	704	722
2.2		Axle load laden front/rear	kg	468 / 1083	474 / 1086	486 / 1092	498 / 1098	560 / 1435	566 / 1438	578 / 1444	590 / 1450
2.3		Axle load unladen front/rear	kg	405 / 146	411 / 149	423 / 155	435 / 161	465 / 230	471 / 233	483 / 239	495 / 245
Räder/Fahrwerk	3.1	Tyres		TPU/PU							
	3.2	Tyre size, front		Ø230x65							
	3.3	Tyre size, rear		Ø80x70							
	3.4	Additional wheels		Ø100x50							
	3.5	Wheels, number front/back (x=driven)		1x+1/4							
	3.6	Tread width, front	b ₁₀ mm	550							
	3.7	Tread width, rear	b ₁₁ mm	390							
Grundabmessungen	4.2	Retracted mast height (h1)	h ₁ mm	1615	1715	1915	2115	1615	1715	1915	2115
	4.3	Free lift (h2)	h ₂ mm	100							
	4.4	Lift (h3)	h ₃ mm	2300	2500	2900	3300	2300	2500	2900	3300
	4.5	Extended mast height (h4)	h ₄ mm	2730	2930	3330	3730	2730	2930	3330	3730
	4.9	Height of tiller handle in drive position min./max.	mm	740 / 1190							
	4.15	Height, lowered	h ₁₃ mm	85							
	4.19	Overall length	l ₁ mm	1685				1880			
	4.20	Length including fork shank	l ₂ mm	535				728			
	4.21.1	Overall width	b ₁ mm	800							
	4.21.2	Overall width	b ₂ mm	800							
	4.22	Fork dimensions	s/ e/l mm	55 x 172 x 1150							
	4.25	Width across forks	b ₅ mm	540							
	4.32	Ground clearance centre of wheelbase	m ₂ mm	30							
	4.34.1	Aisle width (pallet 1000x1200 sideways)	Ast mm	2136				2330			
	4.34.2	Aisle width (pallet 800x1200 length)	Ast mm	2103				2297			
4.35	Turning radius	W _a mm	1270				1464				
Leistungsdaten	5.1	Travel speed laden/unladen	km/h	4.5 / 5							
	5.2	Lift speed laden/unladen	m/s	0.12 / 0.22							
	5.3	Lowering speed laden/unladen	m/s	0.15 / 0.12							

	5.8	Max. gradeability laden/ unladen	%	4 / 10		
	5.10	Service brake		electric		
E-Motor/Elektronik	6.1	Drive motor, performance S2 60 min	kW	0.6		
	6.2	Lift motor, performance with S3	kW	2.2		
	6.3	Battery according to DIN 43531/35/36		no		B
	6.4	Battery voltage/nominal capacity	V / Ah	24 / 105	25.6 / 50	24 / 160
	6.5	Battery weight	kg	52	15	151
	6.6.1	Energy consumption according to EN cycle	kWh/h	0.73		0.91
	6.6.2	CO2 equivalent as per EN 16796	kg/h	0.4		0.5
Sonstiges	8.1	Type of drive control		AC		
	10.7	Sound level as per EN12053, operator's ear	dB (A)	66		
- This data sheet according to VDI guideline 2198 only states the technical values of the standard truck. Different tyres, other masts, additional equipment etc. may result in different values.						

The German production facilities in
Norderstedt, Moosburg and Landsberg
are certified.

ISO 9001
ISO 14001

Jungheinrich fork lift trucks meet
European safety requirements.



 **JUNGHEINRICH**

The Jungheinrich logo, featuring a red upward-pointing arrow above the word 'JUNGHEINRICH' in a bold, black, sans-serif font.