

Powerful, maintenance-free
3-phase AC drive motor

Manoeuvrable and compact

Outstanding driving and
cornering stability

Maintenance-free gel battery
with built-in charger



EJE M13/M15

Electric Low Lift Truck (1,300/1,500 kg)

EJE M13 and EJE M15 were specially developed for the internal transfer of lightweight goods. The 0.6 kW drive motor is ideal for transporting pallets and goods weighing up to 1500 kg over short distances. EJE M13 and EJE M15 are therefore perfect for use in small and medium-sized operations with occasional goods transport requirements.

The energy consumption is enormously reduced by the maintenance-free and powerful three-phase AC technology. This offers the best conditions for fast and cost-effective goods throughput.

This gives the EJE M13 and the EJE M15 their advantages, particularly in confined spaces: Maximum manoeuvrability and optimum view of the forks are guaranteed by the compact design, the low front end length (l2) of just 435 mm and the low overall height.

In addition, 2 sprung and cushioned support wheels ensure safe and stable travel. Flexible use is guaranteed by the gel battery in conjunction with a built-in charger. The battery does not need to be topped up with water.

**JUNGHEINRICH**

EJE M13/M15

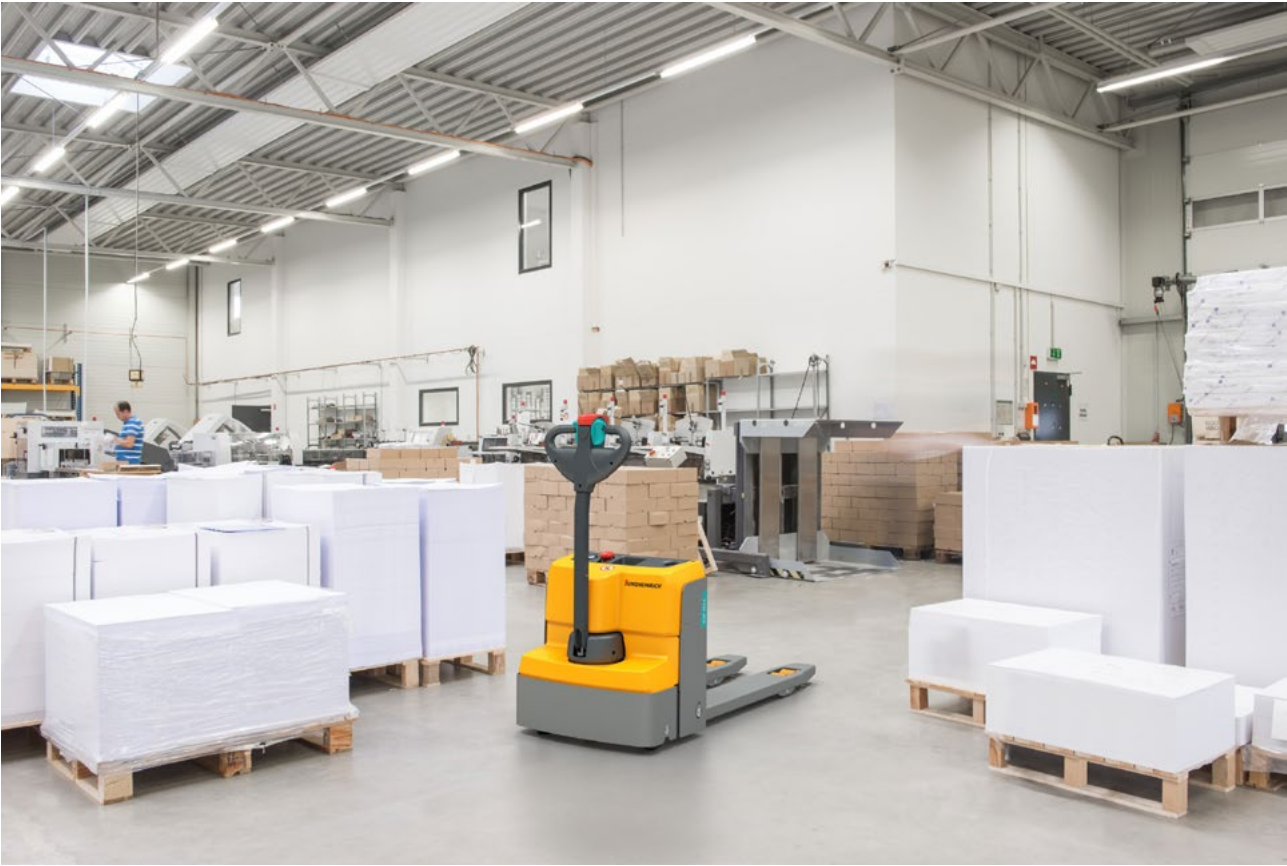
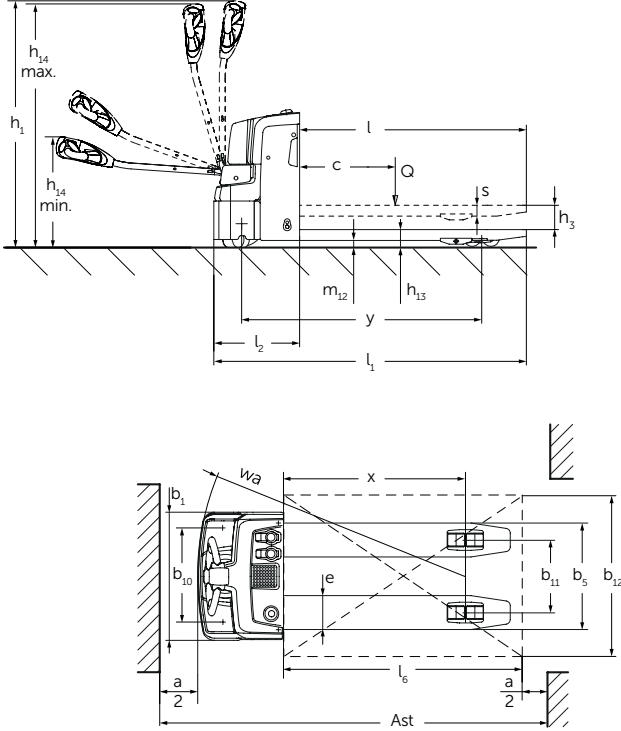

Technical data in line with VDI 2198

		Jungheinrich								
		EJE M13	EJE M13 ⁵⁾	EJE M15	EJE M15 ⁵⁾	EJE M15				
Identification	1.1	Manufacturer (abbreviation)								
	1.2	Model								
	1.3	Drive	Electric							
	1.4	Manual, pedestrian, stand-on, seated, order picker operation	pedestrian							
	1.5	Load capacity/rated load	Q	t	1.3	1.3	1.5	1.5	1.5	
	1.6	Load centre distance	c	mm	600					
	1.8	Load distance	x	mm	914	894	914	894	764	
	1.9	Wheelbase	y	mm	1,212	1,212	1,212	1,212	1,062	
	Weights	2.1.1	Net weight incl. battery (see row 6.5)			kg	214	253	219	258
2.2		Axle loading, laden front/rear			kg	696 / 1,018	716 / 1,037	700 / 1,019	720 / 1,038	700 / 1,019
2.3		Axle loading, unladen front/rear			kg	162 / 52	184 / 69	166 / 53	188 / 70	166 / 53
Wheels / frame	3.1	Tyres	TPU/PU							
	3.2	Tyre size, front			mm	Ø230x65				
	3.3	Tyre size, rear			mm	Ø80x70				
	3.4	Additional wheels (dimensions)			mm	2 x Ø80x40				
	3.5	Wheels, number front/rear (x = driven wheels)				1x+2/4				
	3.6	Tread width, front	b ₁₀	mm	460					
	3.7	Tread width, rear	b ₁₁	mm	368					
Basic dimensions	4.4	Lift			h ₃	mm				
	4.9	Height of tiller in drive position min. / max.			h ₁₄	mm				
	4.15	Height, lowered			h ₁₃	85	90	85	90	85
	4.19	Overall length			l ₁	1,585	1,605	1,585	1,605	1,435
	4.20	Length to face of forks			l ₂	435	455	435	455	435
	4.21	Overall width			b ₁ /b ₂	650 ⁴⁾	650	650 ⁴⁾	650	650 ⁴⁾
	4.22	Fork dimensions			s/e/l	55 / 172 / 1,150	60 / 182 / 1,150	55 / 172 / 1,150	60 / 182 / 1,150	55 / 172 / 1,000
	4.25	Width across forks			b ₅	540 ¹⁾	550	540 ¹⁾	550	540 ¹⁾
	4.32	Ground clearance, centre of wheelbase			m ₂	mm				
	4.33	Aisle width for pallets 1000 x 1200 crossways			Ast	1,643	1,663	1,643	1,663	1,493
4.34	Aisle width for pallets 800 x 1200 lengthways			Ast	1,843	1,863	1,843	1,863	1,693	
4.35	Turning radius			W _a	1,357	1,357	1,357	1,357	1,207	
Performance data	5.1	Travel speed, laden/unladen			km/h	4.5 / 5				
	5.2	Lift speed, laden/unladen			m/s	0.05 / 0.06				
	5.3	Lowering speed, laden/unladen			m/s	0.08 / 0.04				
	5.8	Max. gradeability, laden/unladen			%	4 / 10				
	5.10	Service brake				electric				
Electrics	6.1	Drive motor, output S2 60 min.			kW	0.6				
	6.2	Lift motor kW rating at S3 5%			kW	1.2				
	6.3	Battery as per DIN 43531/35/36 A, B, C, no				no				
	6.4	Battery voltage / nominal capacity			V/Ah	24 / 65 ²⁾	24 / 65 ²⁾	24 / 90 ³⁾	24 / 90 ³⁾	24 / 90 ³⁾
	6.5	Battery weight			kg	35	35	53	53	53
	6.6	Energy consumption according to VDI cycle			kWh/h	0.24	0.24	0.27	0.27	0.27
Misc.	8.1	Type of drive control				AC speedCONTROL				
	8.4	Sound pressure level at operator's ear as per EN 12053			dB (A)	66				

¹⁾ 670 mm also possible

²⁾ Battery voltage/nominal capacity specified for K20; For K5: 24 V, 53.3 Ah

³⁾ Battery voltage/nominal capacity specified for K20; For K5: 24 V, 70 Ah

⁴⁾ If b = 670 mm, b/b = 670 mm

⁵⁾ with integrated weighing function

Benefit from the advantages



Centralised control instruments



Optimum stability thanks to sprung support rollers



Ergonomic tiller arm



Weighing system (optional)

Innovative drive and control technology

Motors with 3-phase AC technology offer many advantages and more efficiency, as well as reduced operating costs thanks to the perfect pairing with our own controllers:

- High efficiency levels with excellent energy management.
- Rapid direction change.
- Maintenance-free drive motor.

Energy-efficient operation

Battery and components are protected and the efficiency is increased through economic energy management:

- Intelligent automatic shut-off engages after 30 minutes without use.
- Energy recovery due to regenerative braking when decelerating.

Compact design

For use in tight spaces the EJE M13/M15 is perfect:

- High manoeuvrability due to short front end length and low overall height.
- Central requirement for all important control instrumentation such as the battery discharge indicator, the hour meter, emergency disconnect and key.
- Sufficient storage space even with slender design.

Work ergonomically

Optimal adaptation of the trucks to the ergonomic needs of the operator:

- Reduced force required while steering due to low-mounted tiller.
- Dual-sided operation of tiller handle for ergonomic and safe use.

Optimum stability

The EJE M13 and the EJE M15 have 2 sprung support rollers installed sideways

next to the drive wheel. This increases the stability of the truck and reduces the risk of transport damage. For the easy loading of pallets, entry rollers are also fitted on the fork tips.

Safe operation

A number of safety provisions reduce the operator's risk of injury:

- Low ground clearance of just 35 mm.
- Fully closed frame, especially the lift cylinder.

Additional equipment

As an option, the EJE M13 and the EJE M15 can be equipped with a weighing system. This enables goods to be weighed and moved using just one truck. 4 weighing cells provide optimum measuring results with a deviation of less than 1% across the entire weighing range.

Jungheinrich UK Ltd.

Head Office:
Sherbourne House
Sherbourne Drive
Tilbrook
Milton Keynes MK7 8HX
Telephone 01908 363100
Fax 01908 363180

info@jungheinrich.co.uk
www.jungheinrich.co.uk

The German production facilities in Norderstedt, Moosburg and Landsberg are certified. **ISO 9001**
ISO 14001

Jungheinrich fork lift trucks meet European safety requirements.



JUNGHEINRICH