



Electric tow tractor

EZS 010

Towing capacity: 1000 kg

JUNGHEINRICH

EZS 010

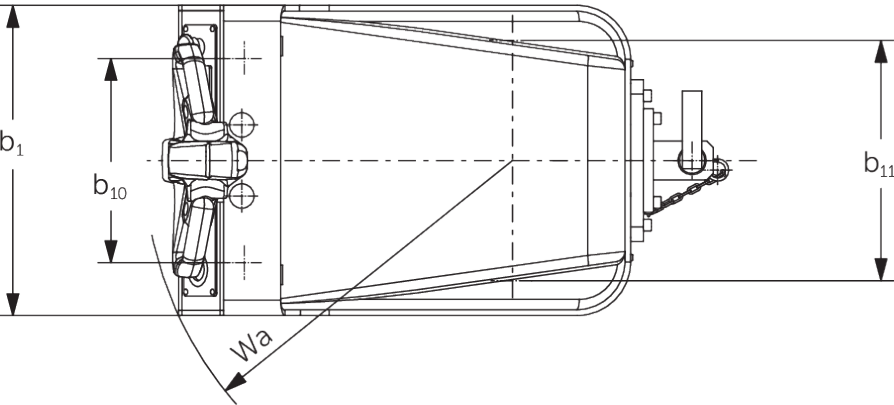
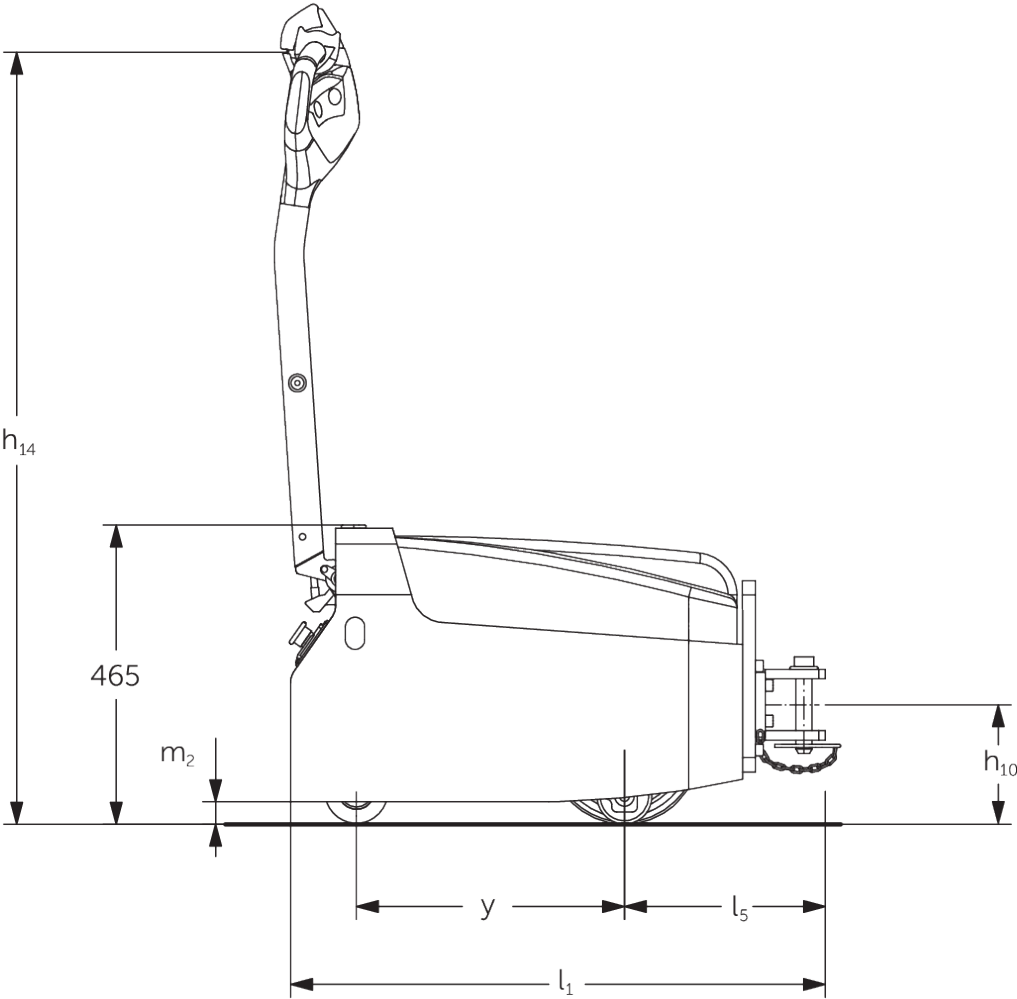

EZS 010

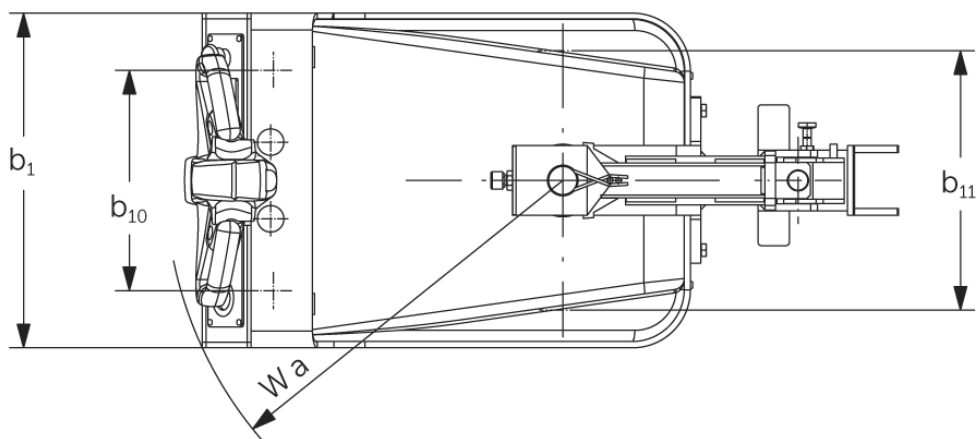
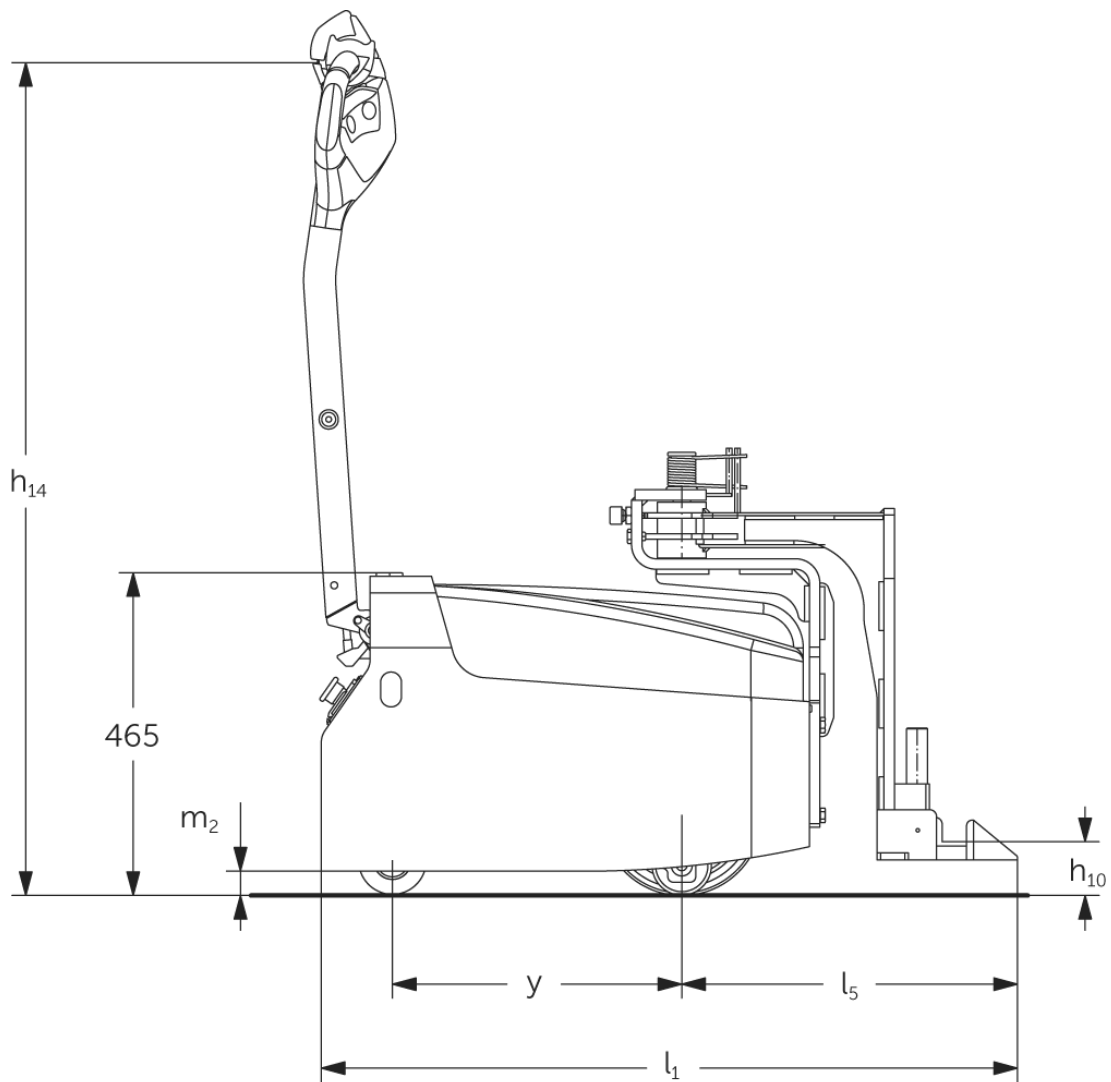

VDI table

Stand-on: 03/2023

Characteristic	1.1	Manufacturer (abbreviated description)		Jungheinrich	
	1.2	Manufacturer's type designation		EZS 010	
	1.3	Drive		Electric	
	1.4	Operation		Pedestrian	
	1.5.3	Towing capacity	Q	kg	1000
	1.7	Rated drawbar pull		N	200
	1.9	Wheelbase	y	mm	415
Weights	2.1.1	Service weight (incl. battery)		kg	190
	2.3	Axle load unladen front/rear		kg	85 / 105
Wheels/suspension system	3.1	Tyres			Polyurethane (PU) / rubber
	3.2	Tyre size, front			Ø 100 x 40
	3.3	Tyre size, rear			Ø 230 x 65
	3.5	Wheels, number front/back (x=driven)			2 / 1x + 2
	3.6	Tread width, front	b ₁₀	mm	315
	3.7	Tread width, rear	b ₁₁	mm	370
Basic dimensions	4.9	Height of tiller handle in drive position min./max.		mm	835 / 1165
	4.12	Coupling height	h ₁₀	mm	150
	4.19	Overall length	l ₁	mm	700
	4.21.1	Overall width	b ₁	mm	480
	4.32	Ground clearance centre of wheelbase	m ₂	mm	35
	4.35	Turning radius	W _a	mm	570
Performance data	5.1	Travel speed laden/unladen		km/h	5.4 / 6
	5.1.1	Reverse travel speed with/without load		km/h	5.4 / 6
	5.5	Drawbar pull laden		N	200
	5.6	Max. drawbar pull laden/unladen		N	600 / 600
	5.10	Service brake			electromagnetic
E-motor/ Electronics	6.1	Drive motor, performance S2 60 min		kW	1
	6.4	Battery voltage/nominal capacity		V / Ah	24 / 63
	6.5	Battery weight		kg	46
Other	8.1	Type of drive control			3-phase AC technology
	10.7	Sound level as per EN12053, operator's ear		dB (A)	63

- This data sheet according to VDI guideline 2198 only states the technical values of the standard truck. Different tyres, other masts, additional equipment etc. may result in different values.

The German production facilities in
Norderstedt, Moosburg and Landsberg
are certified as well as our Genuine Parts
Center in Kaltenkirchen. ISO 9001
ISO 14001

Jungheinrich fork lift trucks meet
European safety requirements. 

**JUNGHEINRICH**