

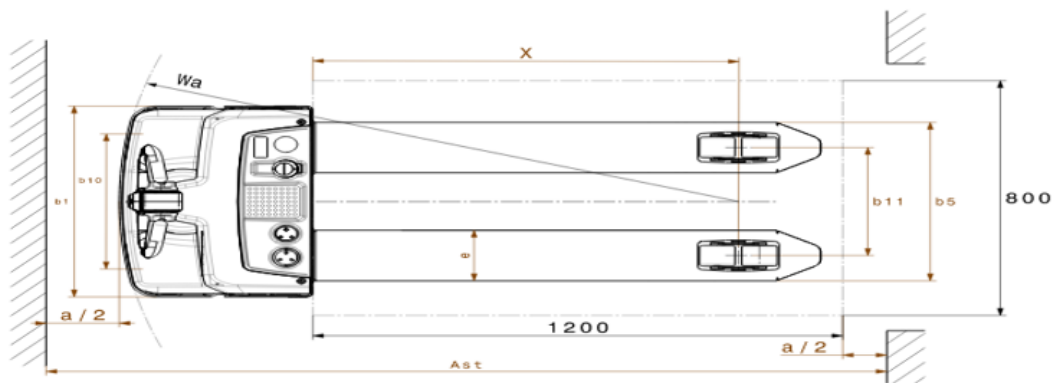

## **Electric pedestrian pallet truck** **EJE M13 / M15**

Lift height: 120 mm / Load capacity: 1300-1500 kg

# EJE M13 / M15

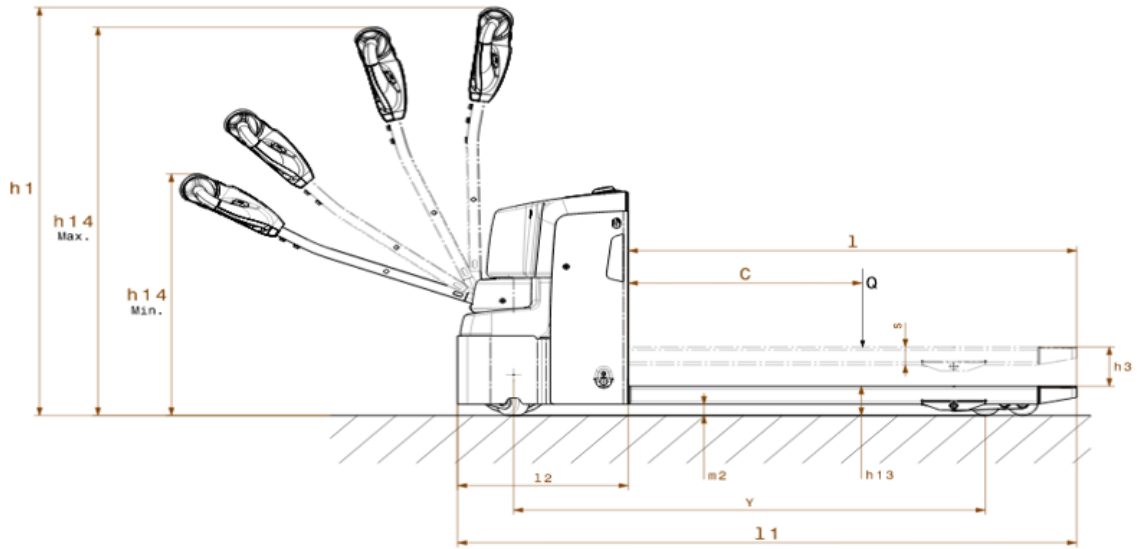

# VDI table

Stand-on: 08/2023

Characteristic	1.1	Manufacturer (abbreviated description)		Jungheinrich							
	1.2	Manufacturer's type designation		<b>EJE M13/M15</b>							
	1.3	Drive		Electric							
	1.4	Operation		Pedestrian							
	1.5	Load capacity/load	Q kg	1300			1500				
	1.6	Load centre distance	c mm	600							
	1.8	Load distance, centre of drive axle to fork	x mm	914	894	914	764	914	894	764	914
	1.9	Wheelbase	y mm	1212			1062	1212		1062	1212
	Weights	2.1.1	Service weight (incl. battery)	kg	199	224	199		224	199	
2.2		Axle load laden front/rear	kg	703 / 816	735 / 809	703 / 816	700 / 1019		730 / 1014	700 / 1019	
2.3		Axle load unladen front/rear	kg	166 / 53	176 / 68	166 / 53		176 / 68	166 / 53		
Wheels/suspension system	3.1	Tyres		TPU/PU							
	3.2	Tyre size, front		Ø210x70							
	3.3	Tyre size, rear		Ø80x70							
	3.4	Additional wheels		2 x Ø80x40							
	3.5	Wheels, number front/back (x=driven)		1x+2/4							
	3.6	Tread width, front	b <sub>10</sub> mm	460							
	3.7	Tread width, rear	b <sub>11</sub> mm	368							
Basic dimensions	4.4	Lift (h <sub>3</sub> )	h <sub>3</sub> mm	120							
	4.9	Height of tiller handle in drive position min./max.	h <sub>14</sub> mm	740 / 1190							
	4.15	Height, lowered	h <sub>13</sub> mm	85	90	85		90	85		
	4.19	total length	l <sub>1</sub> mm	1585	1605	1585	1435	1585	1605	1435	1585
	4.20	Length including fork shank	l <sub>2</sub> mm	435	455	435		455	435		
	4.21.1	total width	b <sub>1</sub> mm	650		670	650		670		
	4.22	Fork dimensions	s/ e/l mm	55 x 172 x 1150	60 x 182 x 1150	55 x 172 x 1150	55 x 172 x 1000	55 x 172 x 1150	60 x 182 x 1150	55 x 172 x 1000	55 x 172 x 1150
	4.25	Width across forks	b <sub>5</sub> mm	540	550	670	540		550	670	
	4.32	Ground clearance centre of wheelbase	m <sub>2</sub> mm	35							
	4.34.1	Aisle width (pallet 1000x1200 sideways)	Ast mm	1643	1663	1643	1493	1643	1663	1493	1643
	4.34.2	Aisle width (pallet 800x1200 length)	Ast mm	1843	1863	1843	1693	1843	1863	1693	1843
	4.35	Turning radius	W <sub>a</sub> mm	1357			1207	1357		1207	1357
	Performance data	5.1	Travel speed laden/unladen	km/h	5 / 5						
5.2		Lift speed laden/unladen	m/s	0.05 / 0.06							
5.3		Lowering speed laden/unladen	m/s	0.08 / 0.04							
5.8		Max. gradeability laden/unladen	%	6 / 16							
5.10		Service brake		electric							
E-motor/Electronics	6.1	Drive motor, performance S2 60 min	kW	1							
	6.2	Lift motor, performance with S3	kW	1.2							
	6.3	Battery according to DIN 43531/35/36		no							
	6.4	Battery voltage/nominal capacity	V / Ah	25.6 / 50							
	6.5	Battery weight	kg	15							

	6.6	Energy consumption according to VDI cycle	kWh/h	0.24	0.27
	6.6.1	Energy consumption according to EN cycle	kWh/h	0.24	0.27
	6.6.2	CO2 equivalent as per EN 16796	kg/h	0.1	0.2
Other	8.1	Type of drive control		AC	
	10.7	Sound level as per EN12053, operator's ear	dB (A)	66	
<p>- This data sheet according to VDI guideline 2198 only states the technical values of the standard truck. Different tyres, other masts, additional equipment etc. may result in different values.</p>					

The German production facilities in  
Norderstedt, Moosburg and Landsberg  
are certified as well as our Genuine Parts  
Center in Kaltenkirchen. ISO 9001  
ISO 14001

Jungheinrich fork lift trucks meet  
European safety requirements. 

**JUNGHEINRICH**