

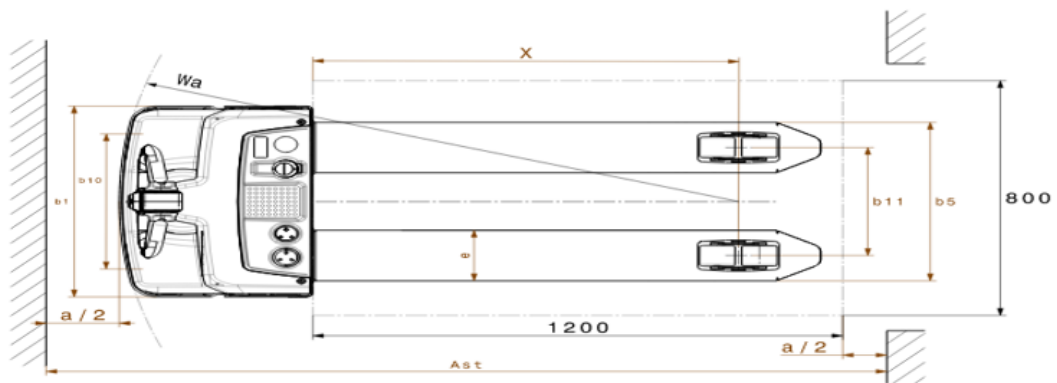

Electric pedestrian pallet truck **EJE BA 115 / 120**

Load capacity: 1500-2000 kg

EJE BA 115 / 120

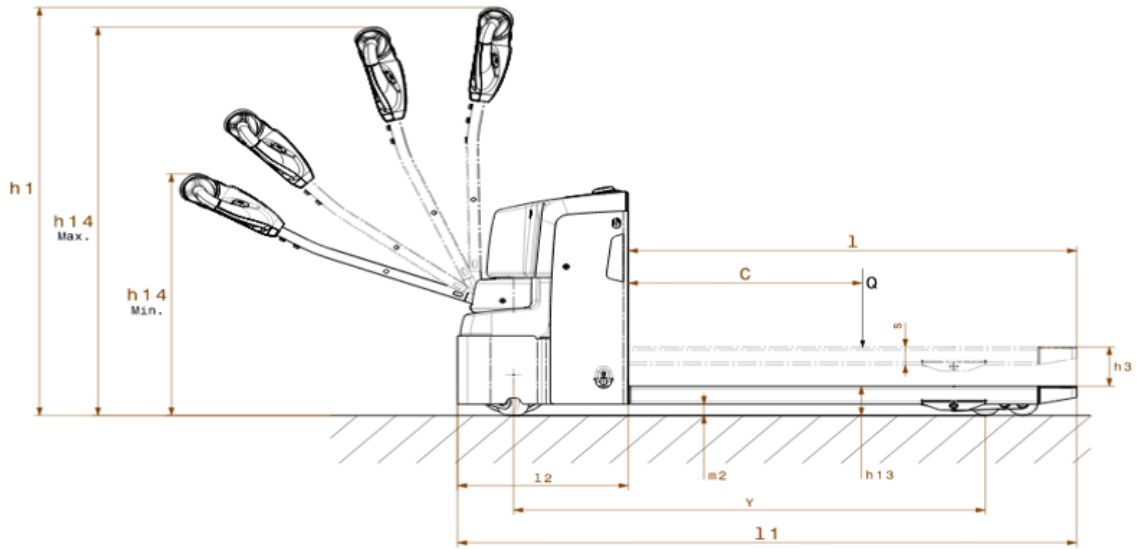

VDI table

Stand-on: 01/2024

Characteristic	Item	Description	Unit	Jungheinrich	
				EJE BA 115	EJE BA 120
Characteristic	1.1	Manufacturer (abbreviated description)		Jungheinrich	
	1.2	Manufacturer's type designation			
	1.3	Drive		Electric	
	1.4	Operation		Pedestrian	
	1.5	Load capacity/load	Q kg	1500	2000
	1.6	Load centre distance	c mm	600	
	1.8	Load distance, centre of drive axle to fork	x mm	914	
	1.9	Wheelbase	y mm	1212	
	Weights	2.1.1	Service weight (incl. battery)	kg	219
2.2		Axle load laden front/rear	kg	703 / 816	
2.3		Axle load unladen front/rear	kg	166 / 53	
Wheels/suspension system	3.1	Tyres		TPU/PU	Polyurethane (PU)
	3.2	Tyre size, front		Ø 210 x 70	
	3.3	Tyre size, rear		Ø 80 x 70	
	3.4	Additional wheels		2 x Ø 80 x 40	
	3.5	Wheels, number front/back (x=driven)		1x+2/4	
	3.6	Tread width, front	b10 mm	460	
	3.7	Tread width, rear	b11 mm	368	
Basic dimensions	4.4	Lift (h3)	h3 mm	120	
	4.9	Height of tiller handle in drive position min./max.	h14 mm	740 / 1190	
	4.15	Height, lowered	h13 mm	85	
	4.19	total length	l1 mm	1585	
	4.20	Length including fork shank	l2 mm	435	
	4.21.1	total width	b1 mm	650	
	4.22	Fork dimensions	s/e/l mm	55 x 172 x 1150	
	4.25	Width across forks	b5 mm	540	
	4.32	Ground clearance centre of wheelbase	m2 mm	35	
	4.34.2	Aisle width (pallet 800x1200 length)	Ast mm	1843	
	4.35	Turning radius	Wa mm	1357	
Performance data	5.1	Travel speed laden/unladen	km/h	5 / 5	
	5.2	Lift speed laden/unladen	m/s	0.05 / 0.06	
	5.3	Lowering speed laden/unladen	m/s	0.04 / 0.02	
	5.8	Max. gradeability laden/unladen	%	6 / 16	
	5.10	Service brake		electric	
E-motor/Electronics	6.1	Drive motor, performance S2 60 min	kW	1	
	6.2	Lift motor, performance with S3	kW	1.2	
	6.3	Battery according to DIN 43531/35/36		no	
	6.4	Battery voltage/nominal capacity	V / Ah	24 / 50	24 / 100
	6.5	Battery weight	kg	15	30
	6.6.1	Energy consumption according to EN cycle	kWh/h	0.16	
	6.6.2	CO2 equivalent as per EN 16796	kg/h	0.1	
Other	8.1	Type of drive control		BLDC brushless direct current	
	10.7	Sound level as per EN12053, operator's ear	dB (A)	64	

- This data sheet according to VDI guideline 2198 only states the technical values of the standard truck. Different tyres, other masts, additional equipment etc. may result in different values.

8.4: 60 dB is per PEAK.

The German production facilities in
Norderstedt, Moosburg and Landsberg
are certified as well as our Genuine Parts
Center in Kaltenkirchen. ISO 9001
ISO 14001

Jungheinrich fork lift trucks meet
European safety requirements. 

**JUNGHEINRICH**