

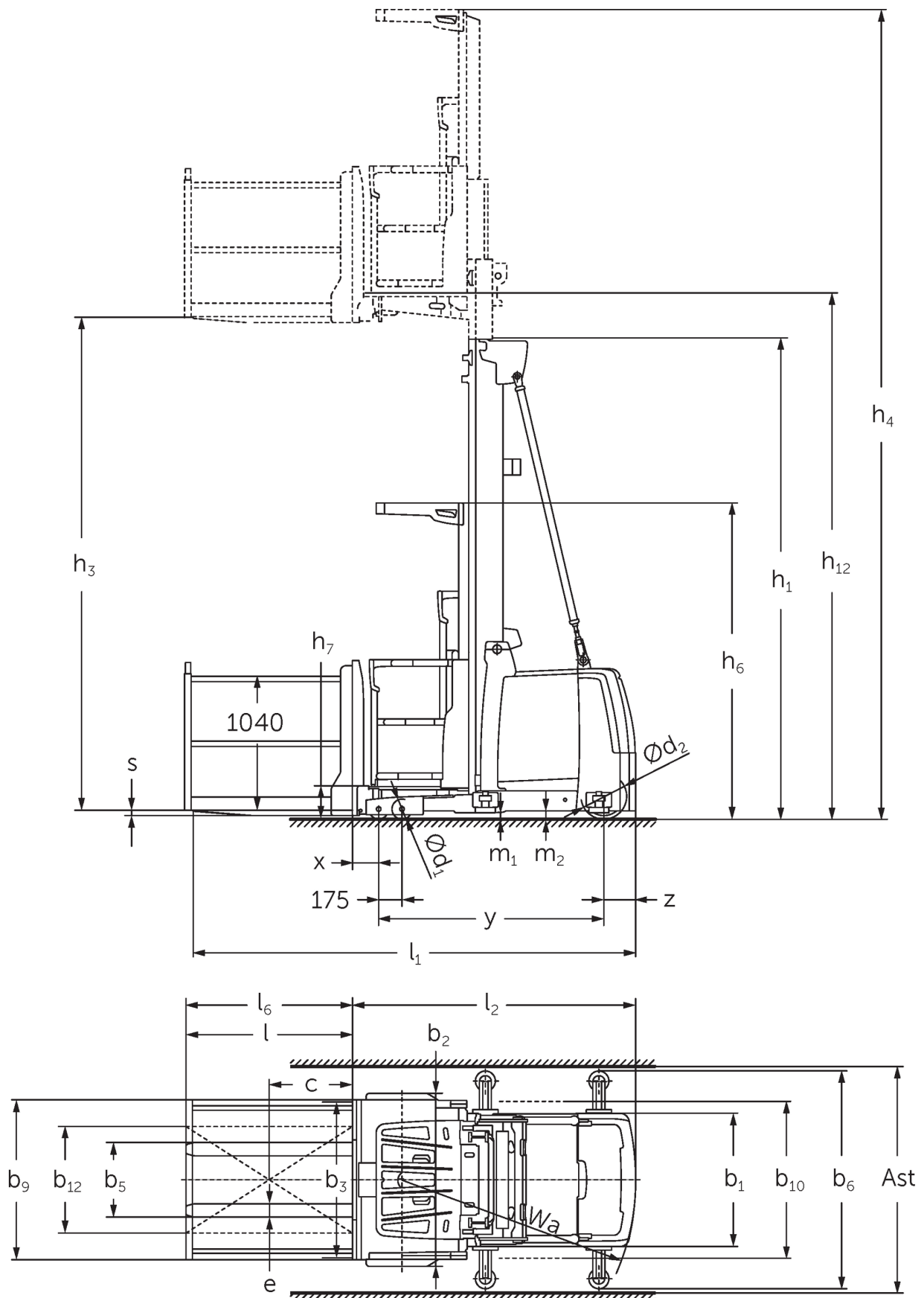

## **Verticale orderpicker** **EKS 310 / 412**

Hefhoogte: 7000-9000 mm / Capaciteit: 1200 kg

# EKS 310 / 412



# EKS 310 / 412

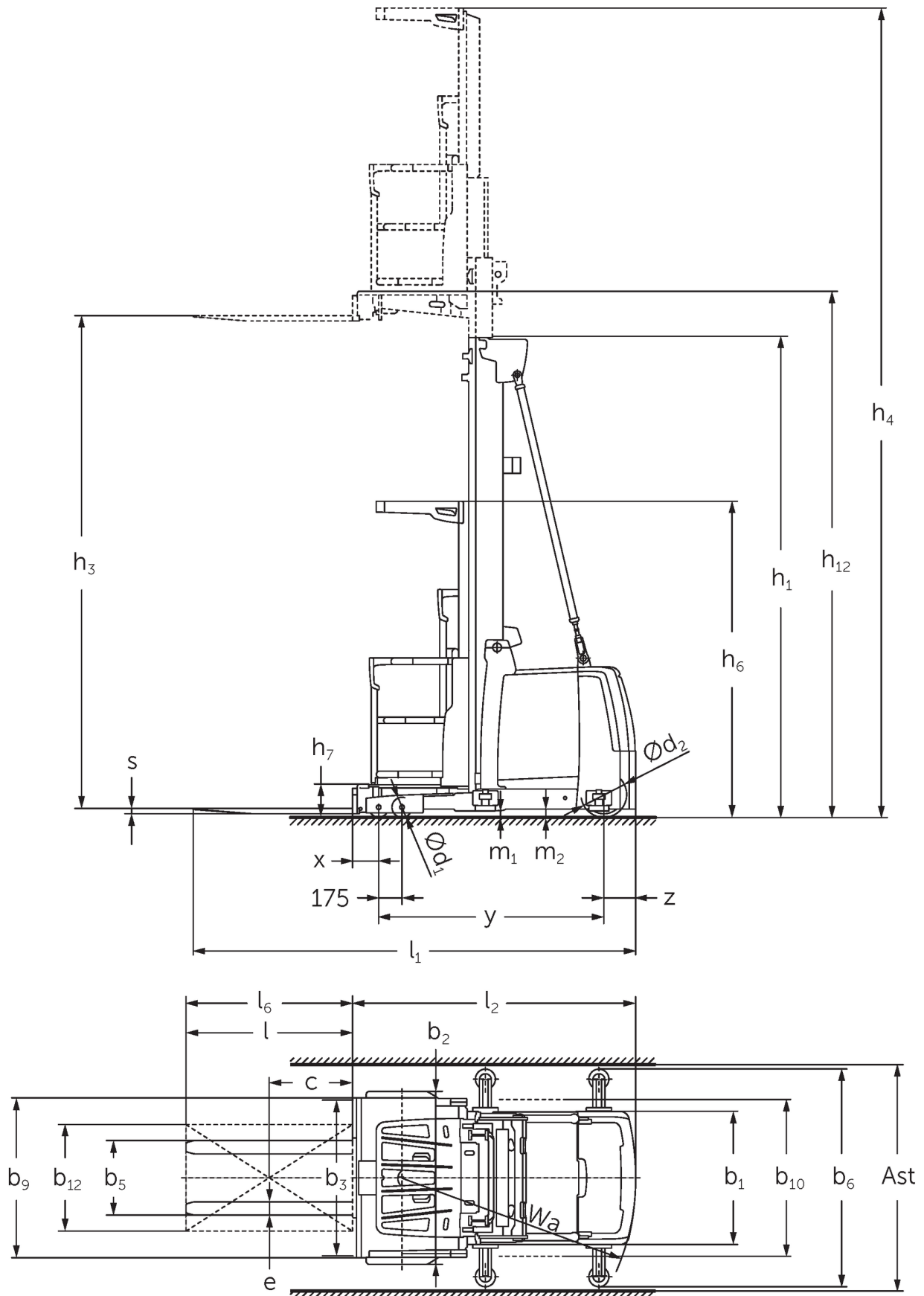

# EKS 310 / 412

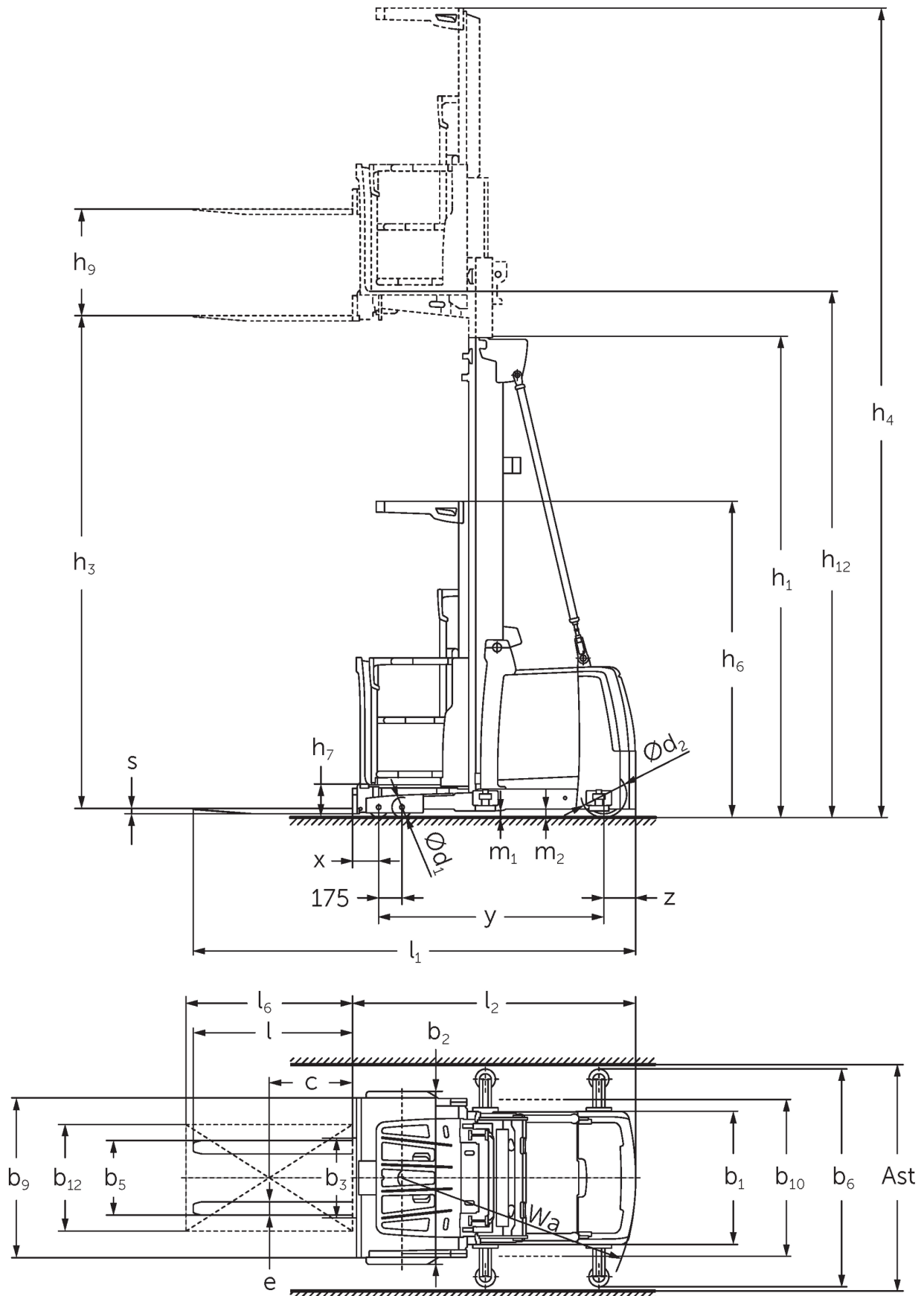

# EKS 310 / 412

EKS 310 Z, EKS 310 L, EKS 310 O	Heffing (h3)	Ingeschoven masthoogte (h1)	Vrije heffing (h2)	Uitgeschoven masthoogte (h4)
Drievoudige mast DT	4750 mm	2370 mm		7120 mm
Drievoudige mast DZ	4750 mm	2370 mm		7120 mm
Tweevoudige mast ZT	2800 mm	2325 mm		5170 mm
	3500 mm	2550 mm		5870 mm
EKS 310 Z, EKS 310 L, EKS 310 O, EKS 412 Z, EKS 412 L, EKS 412 O	Heffing (h3)	Ingeschoven masthoogte (h1)	Vrije heffing (h2)	Uitgeschoven masthoogte (h4)
Drievoudige mast DT	5500 mm	2610 mm		7870 mm
	6000 mm	2780 mm		8370 mm
	6500 mm	2940 mm		8870 mm
	7000 mm	3110 mm		9370 mm
Drievoudige mast DZ	5500 mm	2610 mm	240 mm	7870 mm
	6000 mm	2780 mm	410 mm	8370 mm
	6500 mm	2940 mm	570 mm	8870 mm
	7000 mm	3110 mm	740 mm	9370 mm
Tweevoudige mast ZT	4250 mm	2950 mm		6620 mm
	5000 mm	3330 mm		7370 mm
	5500 mm	3600 mm		7870 mm
	6000 mm	3850 mm		8370 mm
EKS 412 Z, EKS 412 L, EKS 412 O	Heffing (h3)	Ingeschoven masthoogte (h1)	Vrije heffing (h2)	Uitgeschoven masthoogte (h4)
Drievoudige mast DT	7500 mm	3275 mm		9870 mm
	8000 mm	3440 mm		10370 mm
	8500 mm	3610 mm		10870 mm
	9000 mm	3810 mm		11370 mm
Drievoudige mast DZ	7500 mm	3275 mm	905 mm	9870 mm
	8000 mm	3440 mm	1070 mm	10370 mm
	8500 mm	3610 mm	1240 mm	10870 mm
	9000 mm	3810 mm	1440 mm	11370 mm
Tweevoudige mast ZT	6500 mm	4125 mm		8870 mm
	7500 mm	4650 mm		9870 mm
	8500 mm	5150 mm		10870 mm

# VDI-tabel

Stand: 04/2024

			Jungheinrich										
			EKS 310 Z	EKS 310 L	EKS 310 O	EKS 412 Z	EKS 412 L	EKS 412 O					
Kenmerken	1.1	Fabrikant (korte naam)											
	1.2	Typeaanduiding fabrikant											
	1.3	Aandrijving	Elektrisch										
	1.4	Bediening	Orderpicker										
	1.5	Capaciteit/last	Q	kg			1000	1200					
	1.6	Lastwaartepuntafstand	c	mm									
	1.8	Lastafstand	x	mm									
	1.9	Wielbasis	y	mm			1520	1690					
	Gewichten	2.1.1	Eigen gewicht (incl. accu)	kg		2550		2500	3450		3400		
2.2		Aslast met last voor/achter	kg		2740 / 860	2770 / 830	2695 / 855	3425 / 1255	3455 / 1195	3380 / 1220			
2.3		Aslast onbelast voor/achter	kg		1215 / 1335	1270 / 1330	1195 / 1355		1655 / 1795	1580 / 1820			
Wielen/chassis	3.1	Banden	Polyurethaan (PU)										
	3.2	Bandenmaat, voor	Ø 150 x 100										
	3.3	Bandenmaat, achter	Ø 250 x 80				Ø 343 x 114						
	3.5	Wielen, aantal voor/achter (x = aangedreven)	4 / 1 x										
Afmetingen	4.2	Ingeschoven masthoogte (h1)	h1		mm			2950		3330			
	4.4	Heffing (h3)	h3		mm			4250		5000			
	4.5	Uitgeschoven masthoogte (h4)	h4		mm			6620		7370			
	4.7	Hoogte beschermend dak (cabine)	h6		mm			2370					
	4.8.1	Stahoogte	h7		mm			245					
	4.14	Stahoogte geheven	h12		mm			4495		5245			
	4.15	Gedaalde hoogte	h13		mm			60					
	4.19	Totale lengte	l1		mm			3095	3140	3085	3285	3330	3275
	4.20	Lengte inclusief vorkrug	l2		mm			1895	1885		2085	2075	
	4.21.1	Totale breedte	b1		mm			900		1000			
	4.22	Vorkafmetingen	s/ e/l		mm			40 x 100 x 1200	50 x 100 x 1250	50 x 100 x 1200	40 x 100 x 1200	50 x 100 x 1250	50 x 100 x 1200
	4.25	Maat over de vorken	b5		mm			560					
	4.31	Bodemvrijheid met last onder hefmast	m1		mm			50					
4.35	Draaicirkel	Wa		mm			1643		1845				
Prestaties	5.1	Rijsnelheid met last/onbelast	km/u		10 / 10								
	5.2	Hefsnelheid met last/onbelast	m/s		0,25 / 0,3								
	5.3	Daalsnelheid met last/onbelast	m/s		0,3 / 0,25								
	5.10	Rem	regeneratief										
	5.11	Parkeerrem	elektrische veeraccumulator										
E-motor/ elektronica	6.1	Rijmotor, vermogen S2 60 min	kW		3			6					
	6.2	Hefmotor, vermogen bij S3	kW		8								
	6.3	Accu volgens DIN 43531/35/36					6 PzS 930		8 PzS 1240				
	6.4	Accuspanning/nominaal vermogen	V / Ah		24 / 930			24 / 1240					
	6.5	Accugewicht	kg		700			910					
Overig	8.1	Type rijregeling	AC-aandrijfelektronica										
	10.5	Uitvoering besturing	elektrisch										
	10.7	Geluidsdruk niveau volgens EN12053, stuurbuis	dB (A)		60			65					

- Dit typeblad volgens VDI-richtlijn 2198 noemt alleen de technische waarden van de standaardmachine. Afwijkende banden, andere hefmasten, extra systemen etc. kunnen resulteren in andere waarden.

De Duitse fabrieken in Norderstedt,  
Moosburg en Landsberg zijn  
gecertificeerd, evenals ons  
onderdelenmagazijn in Kaltenkirchen. ISO 9001  
ISO 14001

Jungheinrich intern transport materieel  
voldoet aan de Europese  
veiligheidsvoorschriften. 

**JUNGHEINRICH**