

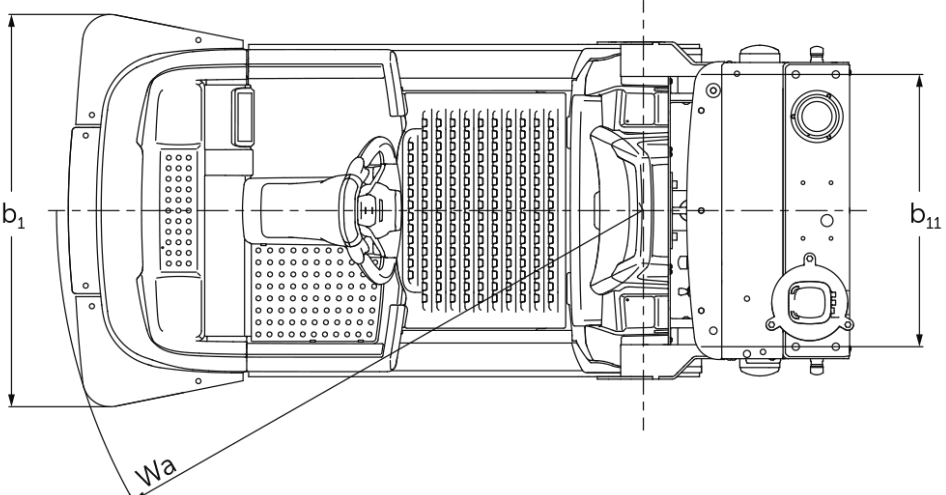

Mobile robot load towing indoor **EZS 350a**

Load capacity: 5000 kg

EZS 350a

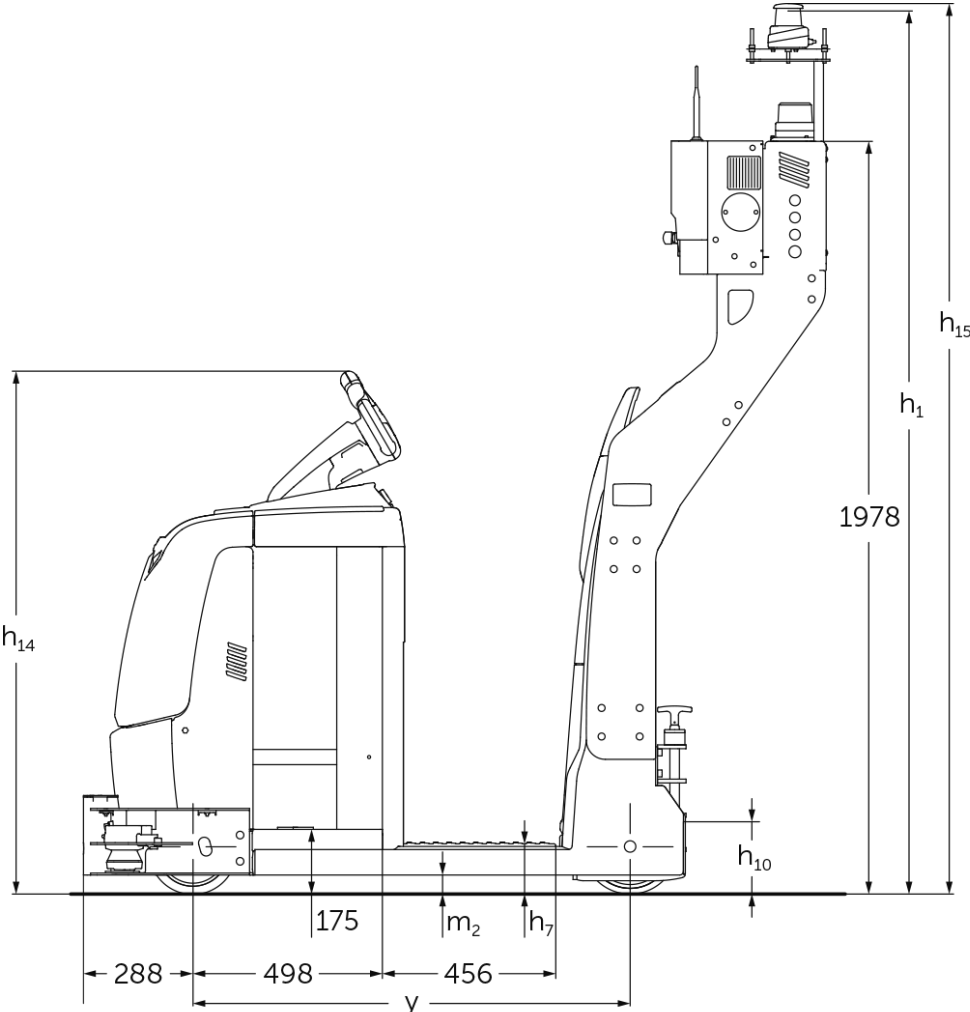

VDI table

Stand-on: 04/2024

Characteristic	1.1	Manufacturer (abbreviated description)		Jungheinrich	
	1.2	Manufacturer's type designation		EZS 350a	
	1.3	Drive		Electric	
	1.4	Operation		Automatic	
	1.5	Load capacity/load	Q	kg	5000
	1.5.3	Towing capacity	Q	kg	5000
	1.9	Wheelbase	y	mm	1149
Weights	2.1.1	Service weight (incl. battery)		kg	1333
	2.3	Axle load unladen front/rear		kg	594 / 739
Wheels/suspension system	3.1	Tyres			Vulkollan ®
	3.2	Tyre size, front			ø230 x 77
	3.3	Tyre size, rear			ø250 x 80
	3.5	Wheels, number front/back (x=driven)			1x/2
	3.7	Tread width, rear	b11	mm	680
Basic dimensions	4.2.1	total height	h15	mm	2273
	4.19	total length	l1	mm	1962
	4.21.1	total width	b1	mm	980
	4.32	Ground clearance centre of wheelbase	m2	mm	50
Performance data	5.1	Travel speed laden/unladen		km/h	8 / 12.5
	5.10	Service brake			generative
E-motor/ Electronics	6.1	Drive motor, performance S2 60 min		kW	2.8
	6.4	Battery voltage/nominal capacity		V / Ah	24 / 620
	6.5	Battery weight		kg	460
Other	8.1	Type of drive control			AC speedCONTROL
	10.7	Sound level as per EN12053, operator's ear		dB (A)	66

- This data sheet according to VDI guideline 2198 only states the technical values of the standard truck. Different tyres, other masts, additional equipment etc. may result in different values.

- 4.12: other coupling heights available
- 4.19: without S3000 option, without coupling
- 5.1: in manual operation (see diagram)
- 5.5: rated drawbar pull

The German production facilities in
Norderstedt, Moosburg and Landsberg
are certified as well as our Genuine Parts
Center in Kaltenkirchen. ISO 9001
ISO 14001

 **JUNGHEINRICH**