



Scharhefwagen

AMX 10 / 10e

Hefhoogte: 714 mm / Capaciteit: 1000 kg

**JUNGHEINRICH**

AMX 10 / 10e

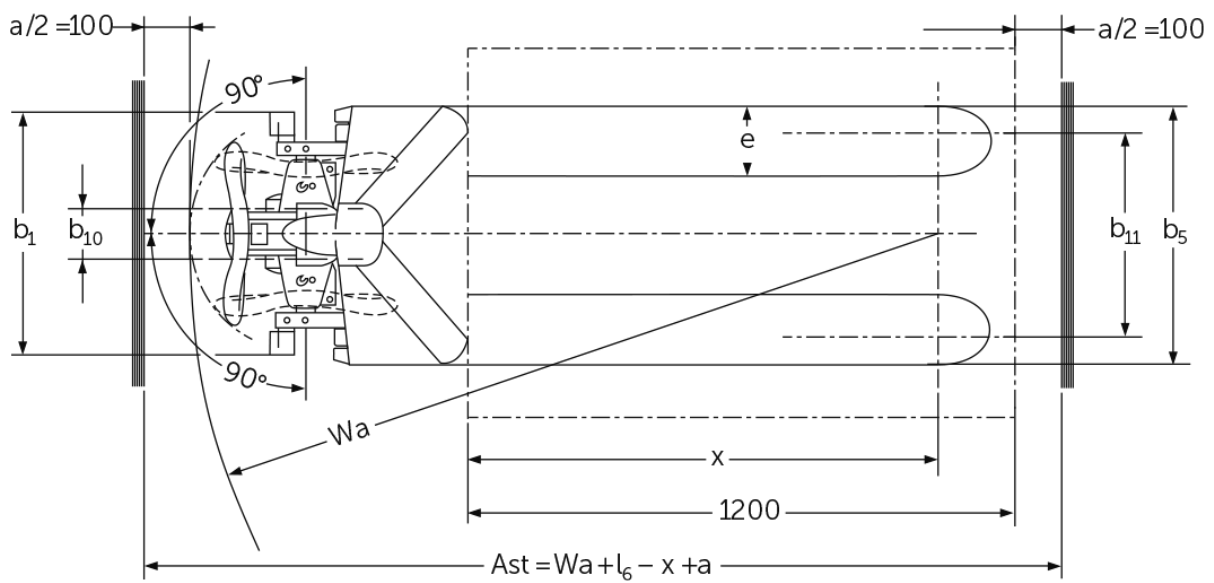
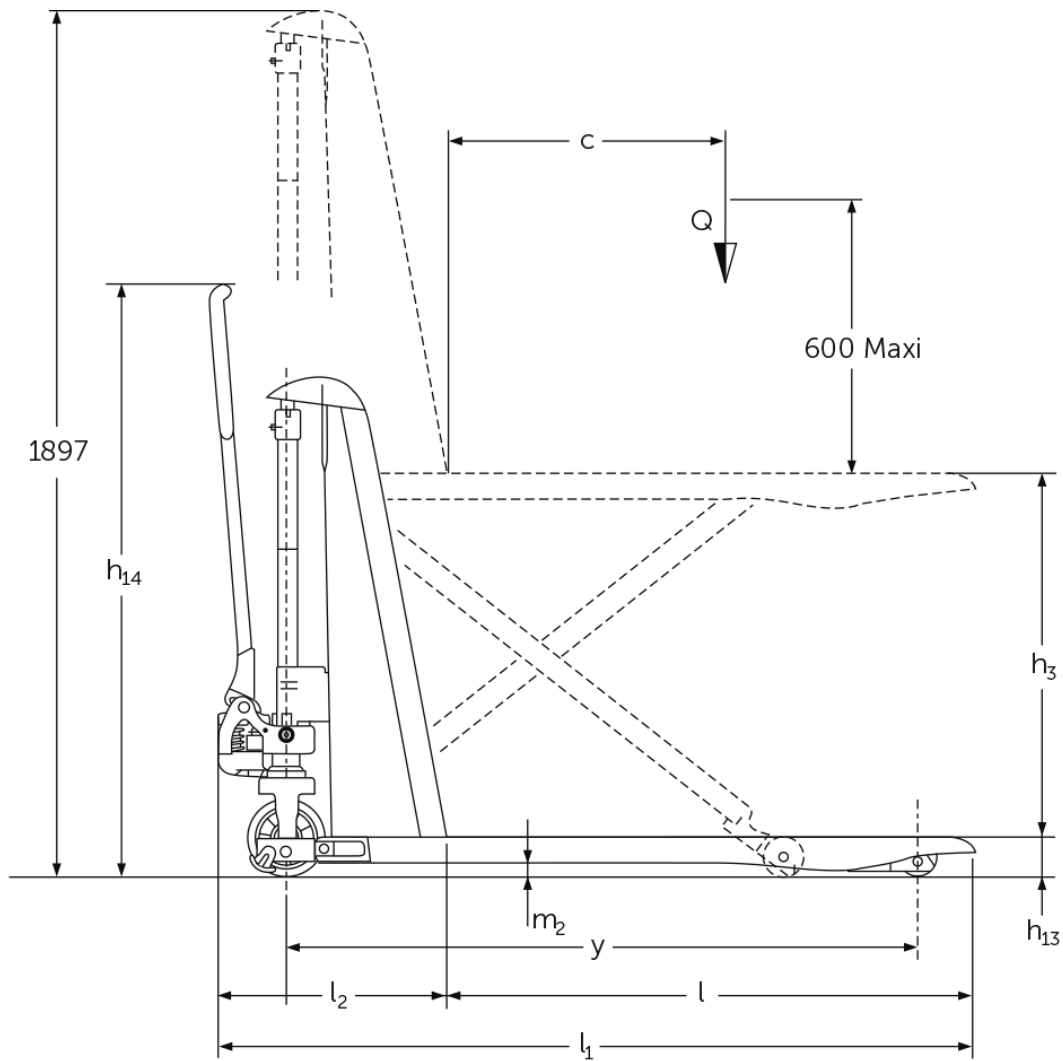

AMX 10 / 10e

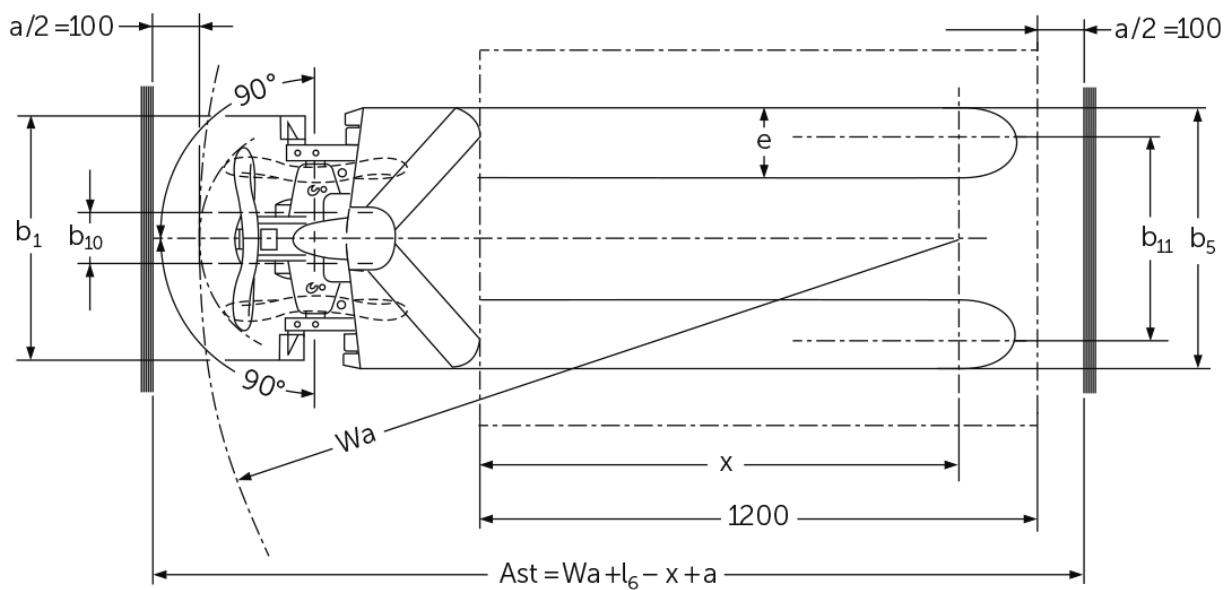
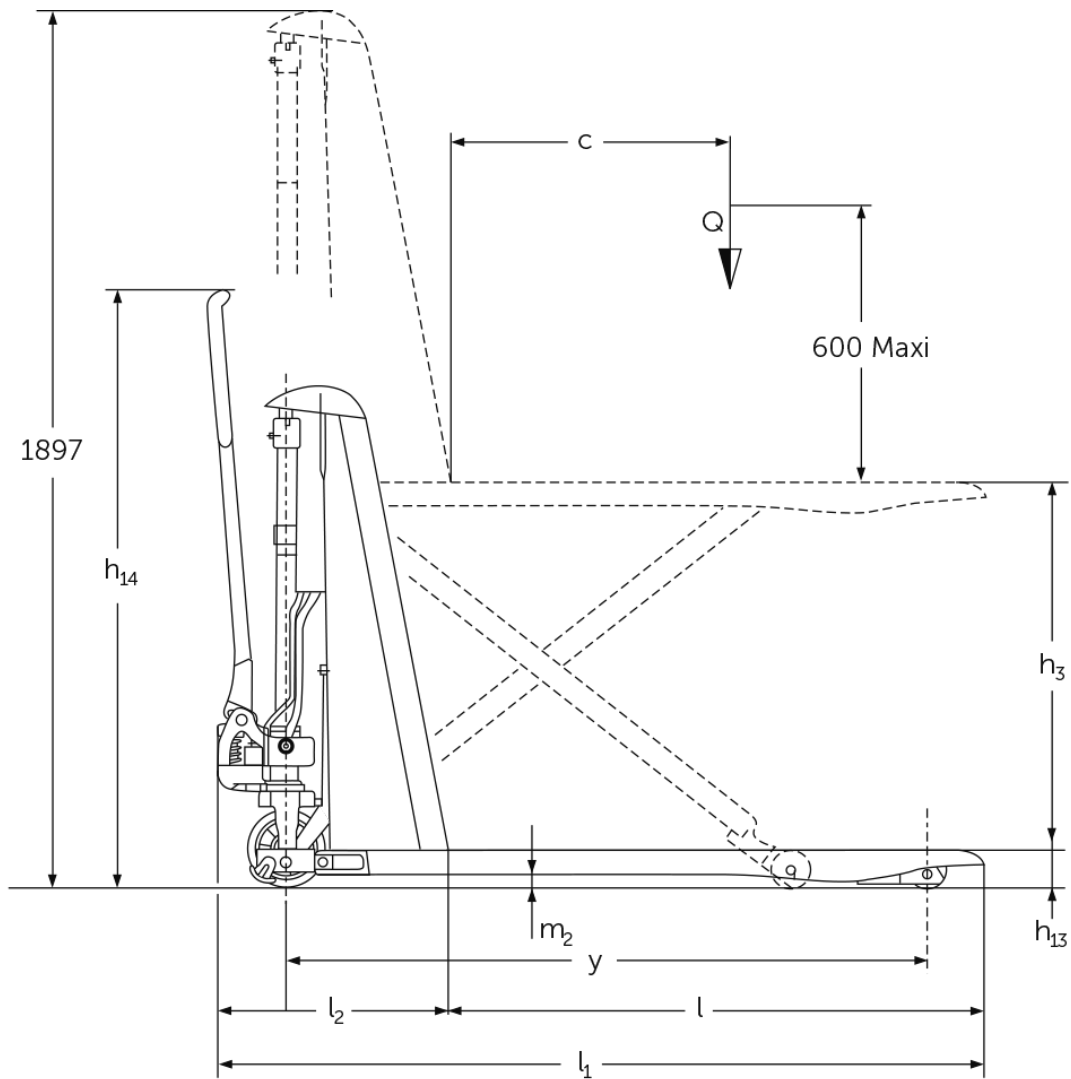

VDI-tabel

Stand: 05/2024

Kenmerken	1.1	Fabrikant (korte naam)		Jungheinrich											
	1.2	Typeaanduiding fabrikant		AMX 10e			AMX 10								
Gewichten	1.3	Aandrijving		Elektrisch	Handmatig										
	1.4	Bediening		Handmatig											
	1.5	Capaciteit/last	Q kg	1000											
	1.6	Lastwaartepuntafstand	c mm	600											
	1.9	Wielbasis	y mm	1383	-		1383	-							
Wielbasis	2.1	Eigen gewicht	kg	195			157								
	2.2	Aslast met last voor/achter	kg	443 / 752	- / -		406 / 751	- / -							
	2.3	Aslast onbelast voor/achter	kg	136 / 59	- / -		101 / 56	- / -							
Wiel/chassis	3.1	Banden		C-GN	N-GN	V-GV	N-GN	C-GN	V-GV	C-GN	N-GN	V-GV	N-GN	C-GN	V-GV
	3.2	Bandenmaat, voor		Ø 170 x 50	-			Ø 170 x 50	-						
	3.3	Bandenmaat, achter		Ø 82 x 62	-			Ø 82 x 62	-						
	3.5	Wielen, aantal voor/achter (x = aangedreven)		2/2	-			2/2	-						
	3.6	Spoorbreedte, voor	b10 mm	109	-			109	-						
	3.7	Spoorbreedte, achter	b11 mm	440	-			440	-						
	Afmetingen	4.4	Heffing (h3)	h3 mm	714										
4.5		Uitgeschoven masthoogte (h4)	h4 mm	1897	-			1897	-						
4.9		Hoogte disselgreep tijdens rijden min./max.	h14 mm	1299	-			1299	-						
4.15		Gedaalde hoogte	h13 mm	86											
4.19		Totale lengte	l1 mm	1650											
4.20		Lengte inclusief vorkrug	l2 mm	500	-			500	-						
4.21.1		Totale breedte	b1 mm	560	-		680	560	680						
4.22		Vorkafmetingen	s/e/l mm	53 x 150 x 1150	150 x 1150			53 x 150 x 1150	150 x 1150						
4.25		Maat over de vorken	b5 mm	560	-		680	560	680						
4.32		Bodemvrijheid midden wielbasis	m2 mm	30	-			30	-						
4.34.2		Werkbreedte (pallet 800x1200 longitudinaal)	Ast mm	2005	-			2005	-						
4.35		Draaicirkel	Wa mm	-			1635	-							
Prestaties		5.3	Daalsnelheid met last/onbelast	m/s	0,13 / 0,05	- / -			0,11 / 0,04	- / -					
	6.2	Hefmotor, vermogen bij S3	kW	0,5			-								
E-motor/elektronica	6.4	Accuspanning/nominaal vermogen	V / Ah	12 / 70			-								
	6.5	Accugewicht	kg	24	-										

- Dit typeblad volgens VDI-richtlijn 2198 noemt alleen de technische waarden van de standaardmachine. Afwijkende banden, andere hefmasten, extra systemen etc. kunnen resulteren in andere waarden.

De Duitse fabrieken in Norderstedt,
Moosburg en Landsberg zijn
gecertificeerd, evenals ons
onderdelenmagazijn in Kaltenkirchen. ISO 9001
ISO 14001

Jungheinrich intern transport materieel
voldoet aan de Europese
veiligheidsvoorschriften. 

**JUNGHEINRICH**