

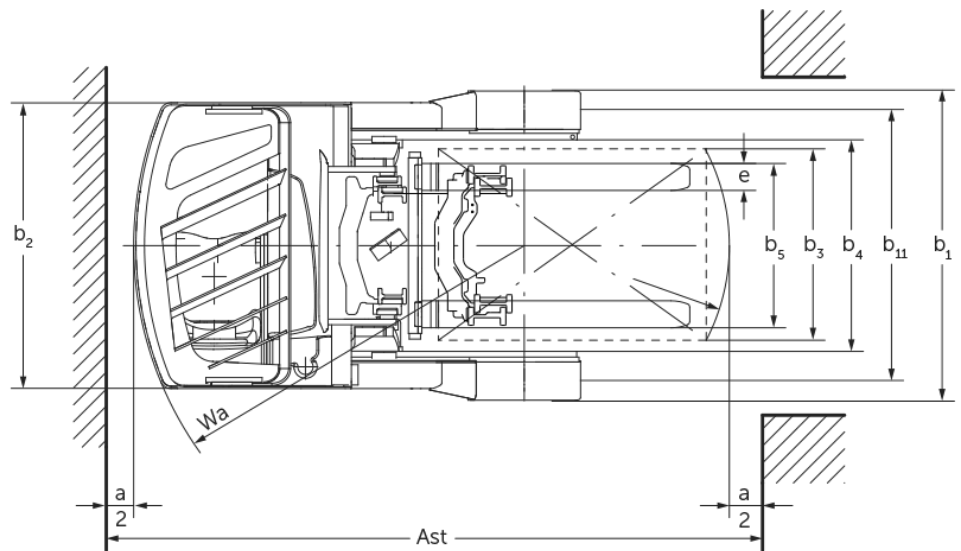

Electric reach truck **ETV C16 / C20**

Lift height: 4250-7400 mm / Load capacity: 1600-2000 kg

ETV C16 / C20

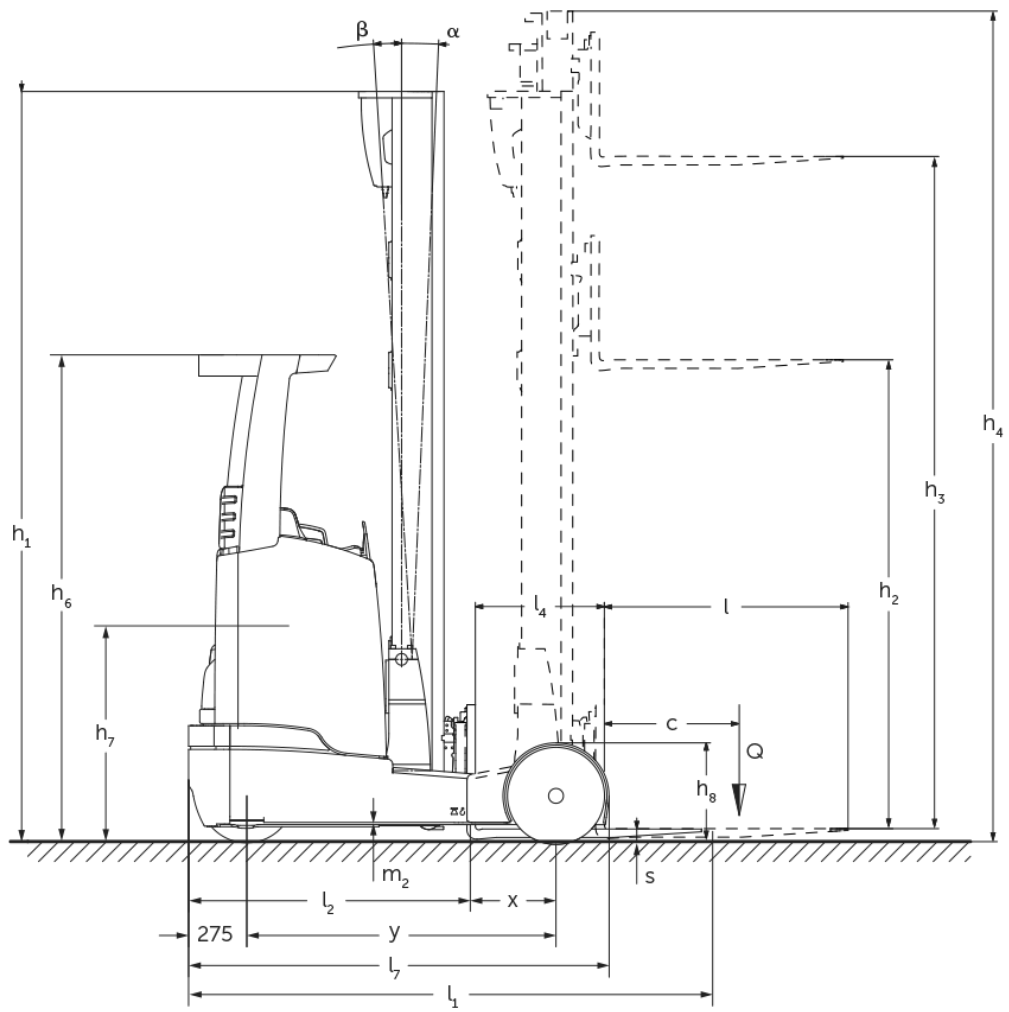

ETV C16 / C20

VDI table

Stand-on: 07/2024

Characteristic	1.1	Manufacturer (abbreviated description)		Jungheinrich	
	1.2	Manufacturer's type designation		ETV C16	ETV C20
	1.3	Drive		Electric	
	1.4	Operation		Sideways-seated	
	1.5	Load capacity/load	Q kg	1600	2000
	1.6	Load centre distance	c mm	600	
	1.8	Load distance, centre of drive axle to fork	x mm	400	421
	1.8.1	Load distance, centre of drive axle to fork, mast extended	mm	290	
	1.9	Wheelbase	y mm	1460	1520
Weights	2.1.1	Service weight (incl. battery)	kg	3640	4010
	2.3	Axle load unladen front/rear	kg	2230 / 1410	2410 / 1600
	2.4	Axle load fork forward laden front/rear	kg	670 / 4570	510 / 5500
	2.5	Axle load fork back laden front/rear	kg	1965 / 3275	2146 / 3846
Wheels/suspension system	3.1	Tyres		Super-elastic (SE)	
	3.2	Tyre size, front		200 / 50-10	
	3.3	Tyre size, rear		180 / 60-10	
	3.5	Wheels, number front/back (x=driven)		1x / 2	
	3.7	Tread width, rear	b11 mm	1210	1240
Basic dimensions	4.1	Forward/backward tilt of mast	a/β °	2 / 4	
	4.2	Retracted mast height (h1)	h1 mm	2300	2400
	4.3	Free lift (h2)	h2 mm	1646	1670
	4.4	Lift (h3)	h3 mm	5300	
	4.5	Extended mast height (h4)	h4 mm	5954	6030
	4.7	Height of overhead guard (cab)	h6 mm	2290	
	4.8	Seat height/stand height	h7 mm	1166	
	4.10	Height of support arms	h8 mm	464	
	4.19	total length	l1 mm	2484	2524
	4.20	Length including fork shank	l2 mm	1320	1360
	4.21.1	total width	b1 mm	1382	1409
	4.21.2	total width	b2 mm	1270	
	4.22	Fork dimensions	s/e/l mm	40 x 120 x 1150	50 x 140 x 1150
	4.23	Fork carriage connection class		2B	
	4.24	Fork carriage width	b3 mm	830	
	4.25	Width across forks	b5 mm	335	356
	4.25.1	Width across forks (min./max.)	b5 mm	335 / 705	356 / 750
	4.26	Width between support arms/loading areas	b4 mm	940	
	4.28	Reach distance	mm	690	711
	4.32	Ground clearance centre of wheelbase	m2 mm	80	
	4.34.1	Aisle width (pallet 1000x1200 sideways)	Ast mm	2784	2829
	4.34.2	Aisle width (pallet 800x1200 length)	Ast mm	2829	2871
	4.35	Turning radius	Wa mm	1735	1795
4.37	Length over the support arms	L7 mm	1986	2046	
Performance data	5.1	Travel speed laden/unladen	km/h	11.8 / 12.2	
	5.2	Lift speed laden/unladen	m/s	0.4 / 0.7	0.32 / 0.6
	5.3	Lowering speed laden/unladen	m/s	0.5 / 0.5	
	5.4	Reach speed laden/unladen	m/s	0.2 / 0.2	0.15 / 0.15
	5.7	Gradeability laden/unladen	%	7 / 10	6 / 10
	5.8	Max. gradeability laden/unladen	%	10 / 15	

	5.9	Acceleration time laden/unladen	s	5.1 / 4.8	5.7 / 5
	5.10	Service brake		electric	
E-motor/Electronics	6.1	Drive motor, performance S2 60 min	kW	7.5	
	6.2	Lift motor, performance with S3	kW	13.3	
	6.3	Battery according to DIN 43531/35/36		DIN 43531 C	
	6.4	Battery voltage/nominal capacity	V / Ah	48 / 560	
	6.5	Battery weight	kg	937	
	6.6	Energy consumption according to VDI cycle	kWh/h	4	4.9
	6.6.1	Energy consumption according to EN cycle	kWh/h	3.59	4.28
	6.6.2	CO2 equivalent as per EN 16796	kg/h	1.9	2.3
	6.7	Throughput	t/h	60.19	65.87
	6.8.1	Energy consumption with max. throughput	kWh/h	3.47	3.85
Other	8.1	Type of drive control		3-phase AC	
	10.1	Operating pressure for attachment	bar	150	
	10.2	Oil flow for attachments	l/min	20	
	10.7	Sound level as per EN12053, operator's ear	dB (A)	70	

- This data sheet according to VDI guideline 2198 only states the technical values of the standard truck. Different tyres, other masts, additional equipment etc. may result in different values.

- VDI no. 1.8: the battery size influences the load distance x
- VDI no. 2.1.1: battery size and mast version affect service weight and axle loads
- VDI no. 2.3: battery size and mast version affect service weight and axle loads
- VDI no. 2.4: battery size and mast version affect service weight and axle loads
- VDI no. 2.5: battery size and mast version affect service weight and axle loads
- VDI no. 4.19: the battery size and the fork length influence the overall length l1
- VDI no. 4.20: the battery size influences the length including fork shank l2
- VDI no. 4.28: the battery size influences the reach distance l4
- VDI no. 4.34.1: the battery size influences the aisle widths
- VDI no. 4.34.2: the battery size influences the aisle widths

The German production facilities in
Norderstedt, Moosburg and Landsberg
are certified as well as our Genuine Parts
Center in Kaltenkirchen. ISO 9001
ISO 14001

Jungheinrich fork lift trucks meet
European safety requirements. 

 **JUNGHEINRICH**