

LION
technology



Electric tow tractor **EZS 570-5100**

Towing capacity: 7000-10000 kg

JUNGHEINRICH

EZS 570-5100

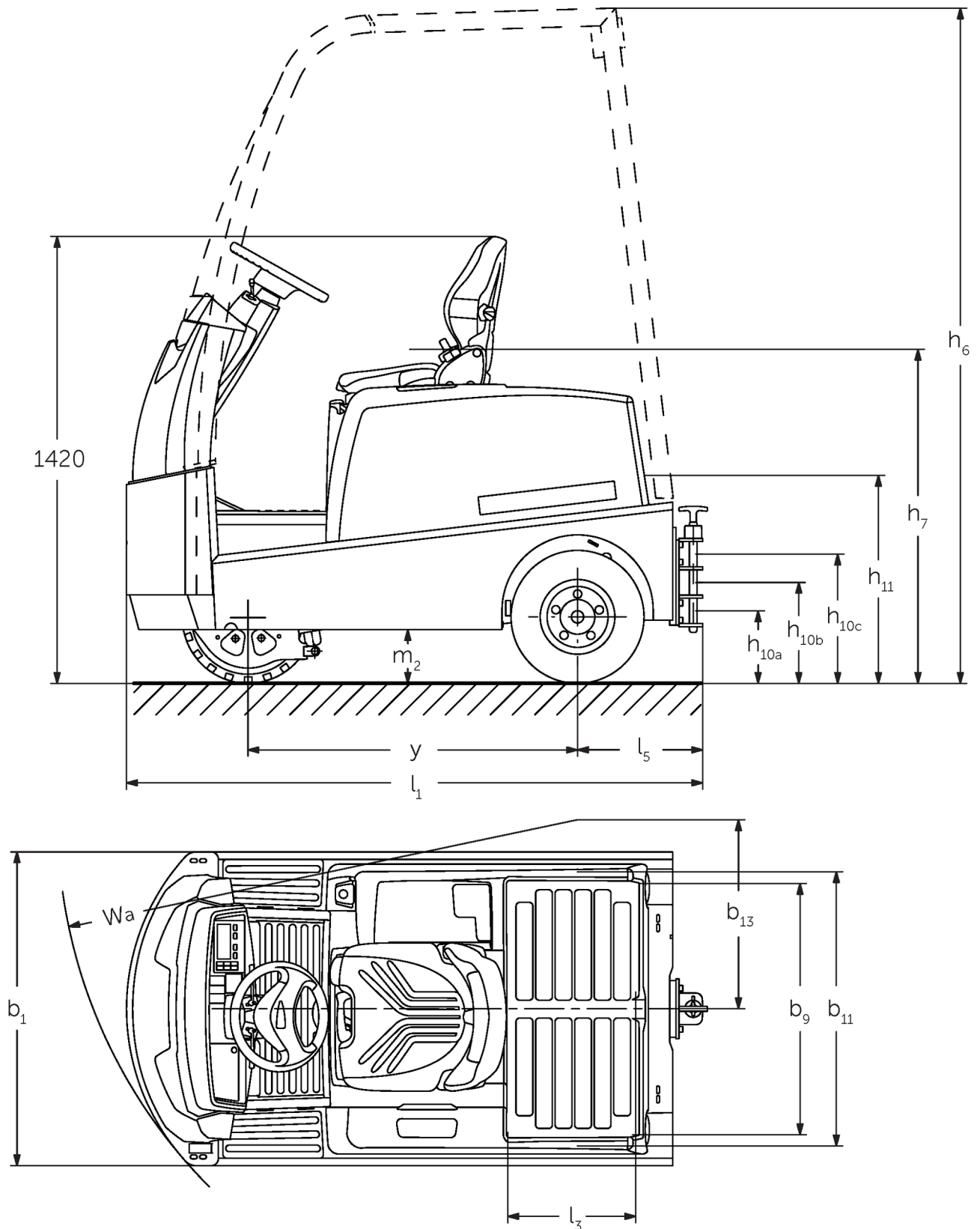

EZS 580, technical drawing, data sheet

EZS 570-5100

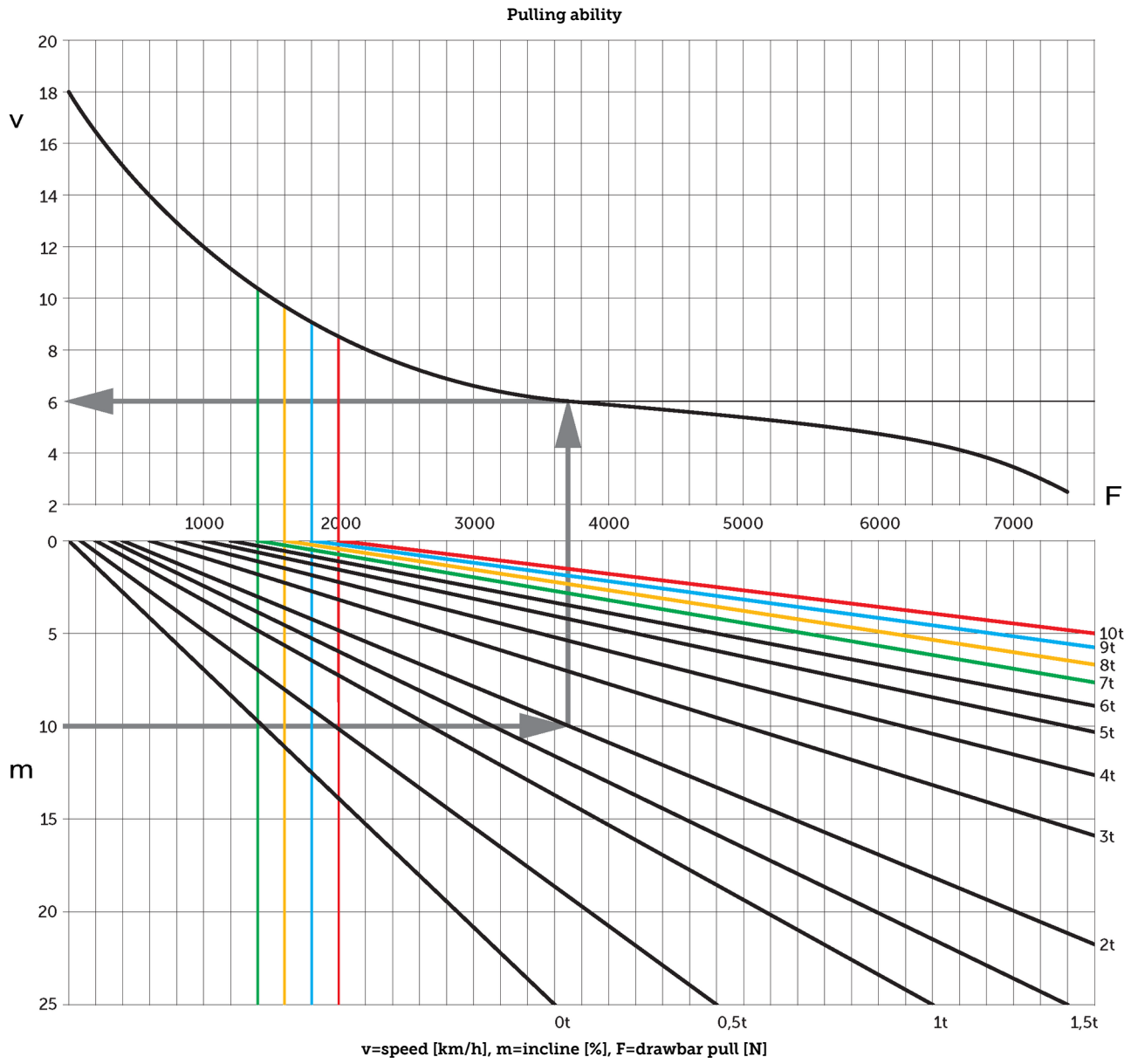

VDI table

Stand-on: 08/2024

Characteristic	Code	Description	Unit	Jungheinrich			
				EZS 570	EZS 580	EZS 590	EZS 5100 XL
Characteristic	1.1	Manufacturer (abbreviated description)		Jungheinrich			
	1.2	Manufacturer's type designation		EZS 570	EZS 580	EZS 590	EZS 5100 XL
	1.3	Drive		Electric			
	1.4	Operation		Seat			
	1.5.3	Towing capacity	Q kg	7000	8000	9000	10000
	1.7	Rated drawbar pull	N	1400	1600	1800	2000
Weights	1.9	Wheelbase	y mm	1035			1250
	2.1.1	Service weight (incl. battery)	kg	1260	1320	1410	1825
Wheels/suspension system	2.3	Axle load unladen front/rear	kg	580 / 680	580 / 740	620 / 790	880 / 945
	3.1	Tyres		Super-elastic (SE)			
	3.2	Tyre size, front		4.00-8	16x6-8		16x6-8
	3.3	Tyre size, rear		4.00-8			
	3.5	Wheels, number front/back (x=driven)		1 / 2x			
	3.6	Tread width, front	b10 mm	0			
	3.7	Tread width, rear	b11 mm	870			
Basic dimensions	4.7	Height of overhead guard (cab)	h6 mm	2150			2140
	4.8	Seat height/stand height	h7 mm	1040			
	4.12	Coupling height	h10 mm	265			
	4.12.1	2. Coupling height	mm	330			
	4.12.2	3. Coupling height	mm	395			
	4.13	Loading height, unladen	mm	650	640		
	4.16	Loading area length	l3 mm	400			
	4.17	Overhang length	mm	375			
	4.18	Loading area width	b9 mm	795			
	4.19	total length	l1 mm	1828			2048
	4.21.1	total width	b1 mm	996			
	4.32	Ground clearance centre of wheelbase	m2 mm	160	130		
	4.35	Turning radius	Wa mm	1652			1866
	4.36	Smallest pivot point distance	b13 mm	600			665
Performance data	5.1	Travel speed laden/unladen	km/h	9 / 18	8.5 / 18		7.5 / 18
	5.5	Drawbar pull laden	N	1400	1600	1800	2000
	5.6	Max. drawbar pull laden/unladen	N	5500 / 5500	6500 / 6500	7500 / 7500	7600 / 7600
	5.10	Service brake		electric			
E-motor/Electronics	6.1	Drive motor, performance S2 60 min	kW	4.5			
	6.4	Battery voltage/nominal capacity	V / Ah	48 / 375			48 / 625
	6.5	Battery weight	kg	575			860
	6.6	Energy consumption according to VDI cycle	kWh/h	0			
	6.6.1	Energy consumption according to EN cycle	kWh/h	1.33	1.5	1.67	1.84
	6.6.2	CO2 equivalent as per EN 16796	kg/h	0.7	0.8	0.9	1
Other	8.1	Type of drive control		Impulse/AC			
	10.7	Sound level as per EN12053, operator's ear	dB (A)	62			

- This data sheet according to VDI guideline 2198 only states the technical values of the standard truck. Different tyres, other masts, additional equipment etc. may result in different values.

The German production facilities in
Norderstedt, Moosburg and Landsberg
are certified as well as our Genuine Parts
Center in Kaltenkirchen. ISO 9001
ISO 14001

Jungheinrich fork lift trucks meet
European safety requirements. 

**JUNGHEINRICH**