



## **Electric ride-on/pedestrian pallet truck**

### **ERE 225i**

Lift height: 122 mm / Load capacity: 2500 kg

# ERE 225i

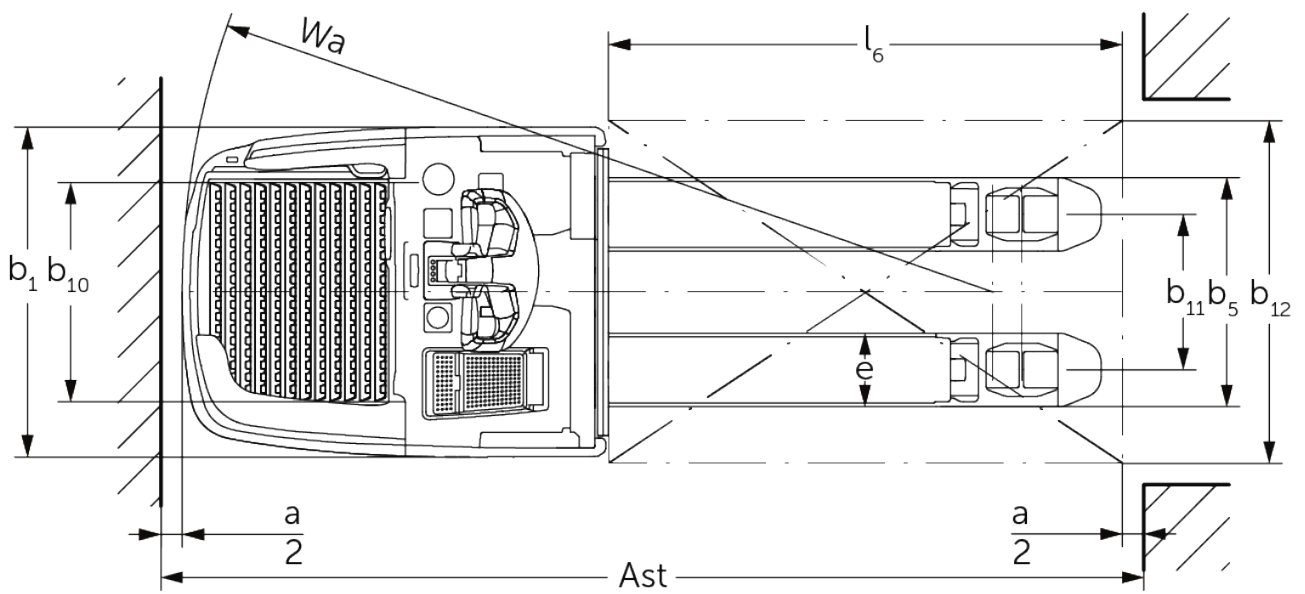
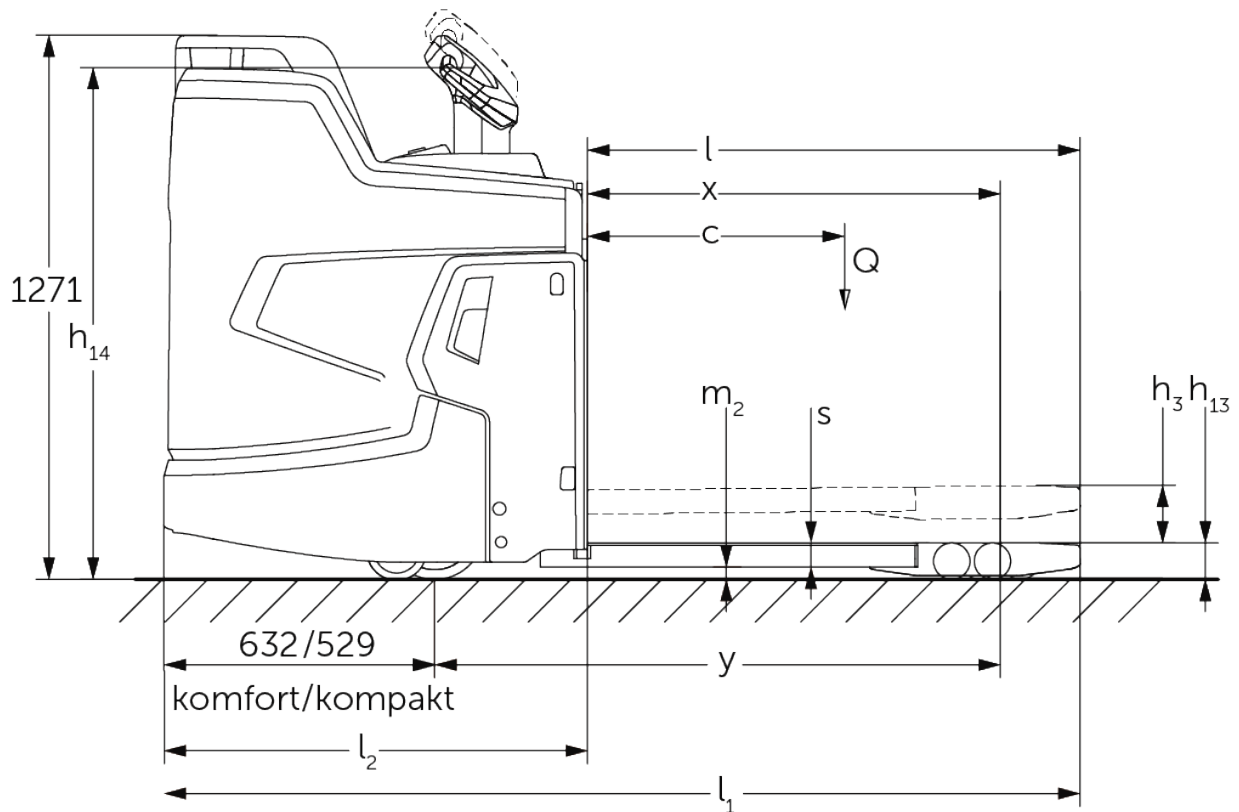

# VDI table

Stand-on: 09/2024

Characteristic	1.1	Manufacturer (abbreviated description)		Jungheinrich
	1.2	Manufacturer's type designation		<b>ERE 225i</b>
	1.3	Drive		Electric
	1.4	Operation		Tiller
	1.5	Load capacity/load	Q kg	2500
	1.6	Load centre distance	c mm	600
	1.8	Load distance, centre of drive axle to fork	x mm	898
	1.9	Wheelbase	y mm	1255
	Weights	2.1.1	Service weight (incl. battery)	kg
2.2		Axle load laden front/rear	kg	1390 / 1920
2.3		Axle load unladen front/rear	kg	670 / 140
Wheels/suspension system	3.1	Tyres		Polyurethane (PU)
	3.2	Tyre size, front		ø 230 x 77
	3.3	Tyre size, rear		ø 85 x 110 / ø 85 x 85
	3.4	Additional wheels		ø 140 x 57
	3.5	Wheels, number front/back (x=driven)		1x + 2 / 2 oder 4
	3.6	Tread width, front	b10 mm	512
	3.7	Tread width, rear	b11 mm	363
Basic dimensions	4.4	Lift (h3)	h3 mm	120
	4.9	Height of tiller handle in drive position min./max.	h14 mm	1215 / 1275
	4.15	Height, lowered	h13 mm	85
	4.19	total length	l1 mm	2139
	4.20	Length including fork shank	l2 mm	989
	4.21.1	total width	b1 mm	770
	4.22	Fork dimensions	s/e/l mm	56 x 172 x 1150
	4.25	Width across forks	b5 mm	535
	4.32	Ground clearance centre of wheelbase	m2 mm	18
	4.34.1	Aisle width (pallet 1000x1200 sideways)	Ast mm	2346
	4.34.2	Aisle width (pallet 800x1200 length)	Ast mm	2396
	4.35	Turning radius	Wa mm	1894
Performance data	5.1	Travel speed laden/unladen (Efficiency   drivePLUS)	km/h	9 / 12   9 / 14
	5.2	Lift speed laden/unladen	m/s	0.05 / 0.07
	5.3	Lowering speed laden/unladen	m/s	0.12 / 0.05
	5.7	Gradeability laden/unladen (Efficiency   drivePLUS)	%	8 / 16   8 / 16
	5.10	Service brake		generative
E-motor/Electronics	6.1	Drive motor, performance S2 60 min (Efficiency   drivePLUS)	kW	2.8   3.2
	6.2	Lift motor, performance with S3	kW	2.2
	6.3	Battery according to DIN 43531/35/36		Jungheinrich Li-ion
	6.4	Battery voltage/nominal capacity	V / Ah	24 / 260
	6.5	Battery weight	kg	100
	6.6.1	Energy consumption according to EN cycle (Efficiency   PLUS)	kWh/h	0.42   0.45
	6.6.2	CO2 equivalent as per EN 16796 (Efficiency   PLUS)	kg/h	0.2   0.3
	6.7	Throughput (Efficiency   PLUS)	t/h	205   210
	6.8	Turnover efficiency according to VDI 2198 (Efficiency   PLUS)	t/kWh	139   131
6.8.1	Energy consumption with max. throughput (Efficiency   PLUS)	kWh/h	1.48   1.6	

Other	10.7	Sound level as per EN12053, operator's ear	dB (A)	67.1
<p>- This data sheet according to VDI guideline 2198 only states the technical values of the standard truck. Different tyres, other masts, additional equipment etc. may result in different values.</p>				

The values in the table apply to the fixed stand-on platform, integrated M battery compartment, 260-Ah battery, fork length 1,150 mm, raised load section.

Entry height for stand-on platform: 202 / 214 mm (stand-on platform standard / stand-on platform suspension adjustable).

Ground clearance at end of stand-on platform: 117 / 98 mm (stand-on platform standard / stand-on platform compact).

- VDI no. 1.8: lowered load section: x + 66 mm.
- VDI no. 1.9: lowered load section: y + 66 mm.
- VDI no. 4.19: with compact stand-on platform: l1 - 103 mm.
- VDI no. 4.20: with compact stand-on platform: l2 - 103 mm.
- VDI no. 4.34.1: diagonal as per VDI: aisle width + 357 mm. With compact stand-on platform: aisle width - 108 mm.
- VDI no. 4.34.2: diagonal as per VDI: aisle width + 199 mm. With compact stand-on platform: aisle width - 108 mm.
- VDI no. 4.35: lowered load section: Wa + 66 mm. With compact stand-on platform: aisle width - 108 mm.

Friedrich-Ebert-Damm 129  
22047 Hamburg  
Telefon 0800 222 585858\*  
\*Deutschlandweit kostenlos

The German production facilities in  
Norderstedt, Moosburg and Landsberg  
are certified as well as our Genuine Parts  
Center in Kaltenkirchen. ISO 9001  
ISO 14001

Jungheinrich fork lift trucks meet  
European safety requirements.



 **JUNGHEINRICH**