

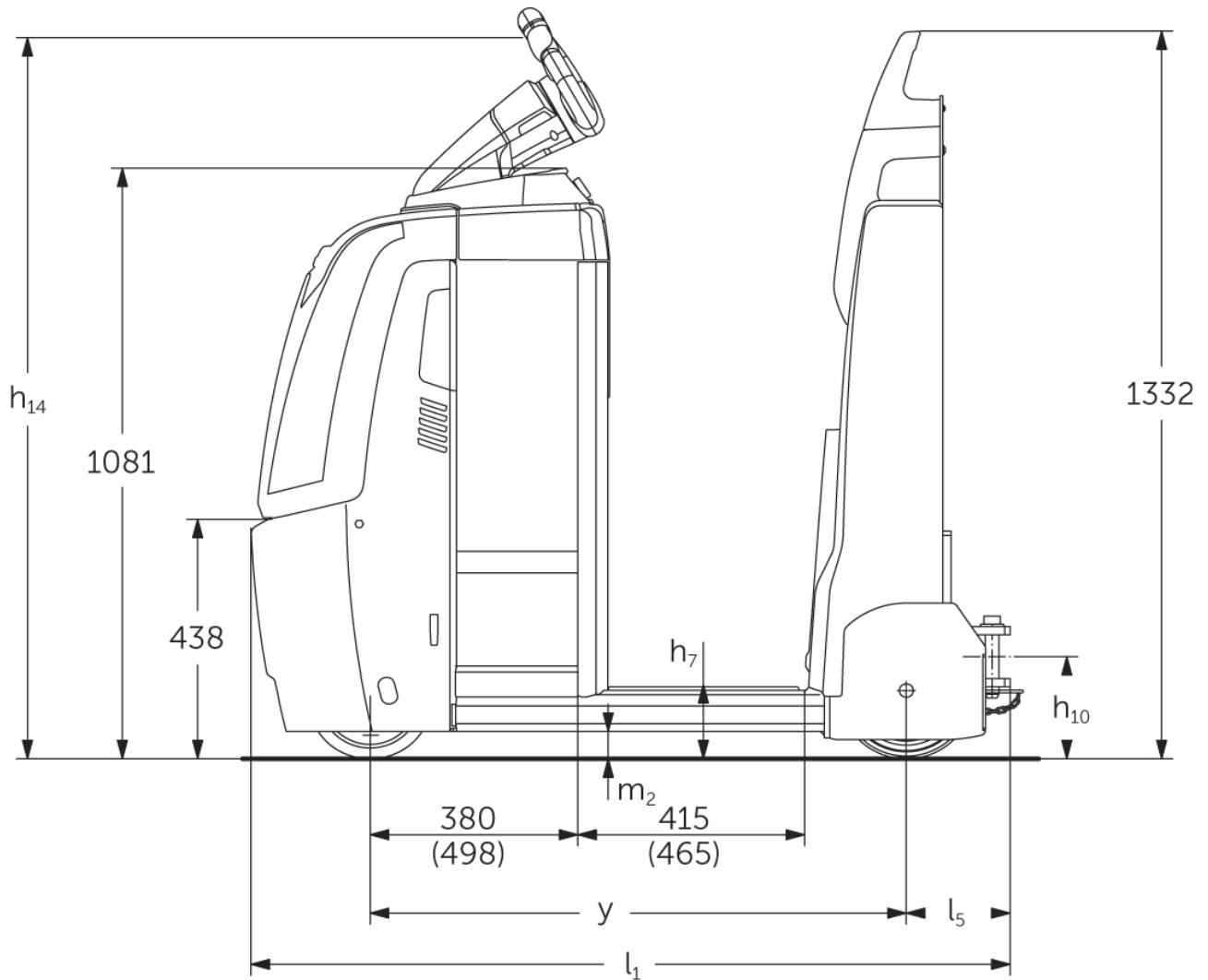

Electric tow tractor **EZS 350**

Towing capacity: 5000 kg

EZS 350



EZS 350

Pulling ability

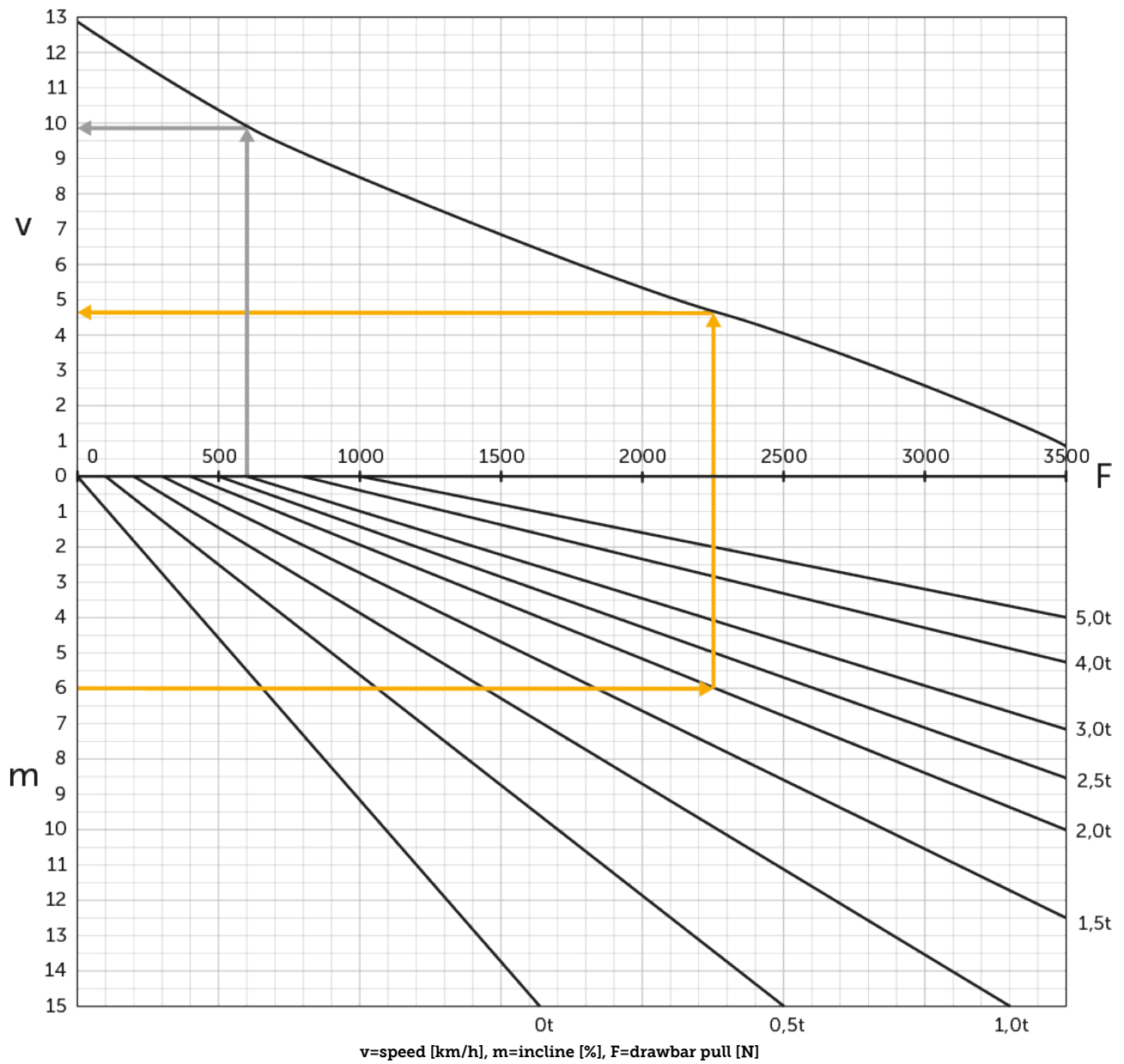

VDI table

Stand-on: 11/2024

Characteristic	1.1	Manufacturer (abbreviated description)	•	Jungheinrich			
				EZS 350 L Std	EZS 350 L Comfort	EZS 350 XL Std	EZS 350 XL Comfort
Characteristic	1.2	Manufacturer's type designation					
	1.3	Drive		Electric			
	1.4	Operation		Stand-on			
	1.5.3	Towing capacity	Q kg	5000			
	1.7	Rated drawbar pull	N	1000			
	1.9	Wheelbase	y mm	980	1030	1098	1148
Weights	2.1.1	Service weight (incl. battery)	kg	996	1006	1091	1101
	2.3	Axle load unladen front/rear	kg	505 / 491	510 / 496	565 / 526	570 / 531
Wheels/suspension system	3.1	Tyres		Polyurethane / Super-elastic			
	3.2	Tyre size, front		ø230 x 77			
	3.3	Tyre size, rear		ø250 x 80			
	3.5	Wheels, number front/back (x=driven)		1x/2			
	3.7	Tread width, rear	b11 mm	680			
Basic dimensions	4.8	Seat height/stand height	h7 mm	135			
	4.9	Height of tiller handle in drive position min./ max.	h14 mm	1320			
	4.12	Coupling height	h10 mm	158			
	4.19	total length	l1 mm	1390	1440	1508	1558
	4.21.1	total width	b1 mm	810			
	4.32	Ground clearance centre of wheelbase	m2 mm	50			
	4.35	Turning radius	Wa mm	1210	1260	1328	1378
Performance data	5.1	Travel speed laden/unladen	km/h	8 / 12.5			
	5.1.1	Reverse travel speed with/without load	km/h	6 / 6			
	5.5	Drawbar pull laden	N	1000			
	5.6	Max. drawbar pull laden/unladen	N	3700 / 3700			
	5.10	Service brake		electromagnetic/generative			
E-motor/ Electronics	6.1	Drive motor, performance S2 60 min	kW	2.8			
	6.4	Battery voltage/nominal capacity	V / Ah	24 / 465		24 / 620	
	6.5	Battery weight	kg	370		470	
	6.6.1	Energy consumption according to EN cycle	kWh/h	1.15			
	6.6.2	CO2 equivalent as per EN 16796	kg/h	0.6			
	Other	8.1	Type of drive control		AC speedCONTROL		
10.7		Schalldruckpegel nach EN12053	dB (A)	66			

- This data sheet according to VDI guideline 2198 only states the technical values of the standard truck. Different tyres, other masts, additional equipment etc. may result in different values.

- VDI no. 4.9: the height applies to the version with jetPILOT
- VDI no. 4.12: the value for the coupling height applies to a single plug-in coupling. Other coupling heights are available
- VDI no. 4.19: as different coupling systems are available, the specification applies to the overall length including a single plug-in coupling
- VDI no. 5.1: see tow load diagram
- VDI no. 5.5: this value is the rated drawbar pull
- VDI no. 5.6: see tow load diagram

The German production facilities in
Norderstedt, Moosburg and Landsberg
are certified as well as our Genuine Parts
Center in Kaltenkirchen. ISO 9001
ISO 14001

Jungheinrich fork lift trucks meet
European safety requirements. 

**JUNGHEINRICH**