

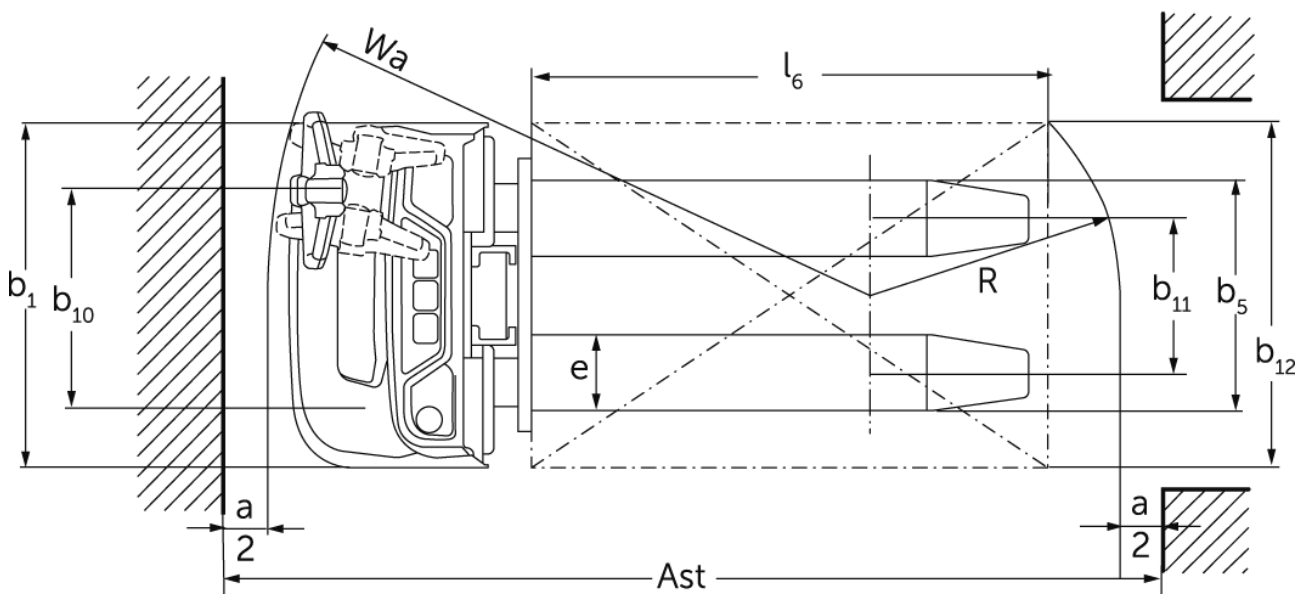

## **Electric pedestrian stacker** **EJC 010i**

Lift height: 2300-3600 mm / Load capacity: 1000 kg

# EJC 010i



# VDI table

Stand-on: 11/2024

Characteristic	1.1	Manufacturer (abbreviated description)	Jungheinrich						
	1.2	Manufacturer's type designation	EJC 010i (2300ZT)	EJC 010i (2500ZT)	EJC 010i (2900ZT)	EJC 010i (3200ZT)	EJC 010i (3600ZT)		
	1.3	Drive	Electric						
	1.4	Operation	Pedestrian						
	1.5	Load capacity/load	Q	kg	1000				
	1.6	Load centre distance	c	mm	600				
	1.8	Load distance, centre of drive axle to fork	x	mm	707				
	1.9	Wheelbase	y	mm	1141				
Weights	2.1.1	Service weight (incl. battery)	kg		601	611	630	645	664
	2.2	Axle load laden front/rear	kg		515 / 1086	520 / 1091	520 / 1100	538 / 1107	548 / 1116
	2.3	Axle load unladen front/rear	kg		425 / 176	430 / 181	440 / 190	448 / 197	458 / 206
Wheels/suspension system	3.1	Tyres	Polyurethane (PU)						
	3.2	Tyre size, front	Ø210 x 70						
	3.3	Tyre size, rear	ø75x105						
	3.4	Additional wheels	ø140x54						
	3.5	Wheels, number front/back (x=driven)	1x +1 / 2						
	3.6	Tread width, front	b10	mm	507				
	3.7	Tread width, rear	b11	mm	405				
Basic dimensions	4.2	Retracted mast height (h1)	h1	mm	1650	1750	1950	2100	2300
	4.3	Free lift (h2)	h2	mm	100				
	4.4	Lift (h3)	h3	mm	2300	2500	2900	3200	3600
	4.5	Extended mast height (h4)	h4	mm	2775	2975	3375	3675	4075
	4.9	Height of tiller handle in drive position min./max.	h14	mm	750 / 1260				
	4.15	Height, lowered	h13	mm	90				
	4.19	total length	l1	mm	1754				
	4.20	Length including fork shank	l2	mm	604				
	4.21.1	total width	b1	mm	800				
	4.22	Fork dimensions	s/ e/l	mm	60 x 178 x 1150				
	4.32	Ground clearance centre of wheelbase	m2	mm	24				
	4.34.1	Aisle width (pallet 1000x1200 sideways)	Ast	mm	2002				
	4.34.2	Aisle width (pallet 800x1200 length)	Ast	mm	2052				
	4.35	Turning radius	Wa	mm	1359				
Performance data	5.1	Travel speed laden/unladen	km/h		5.3 / 5.3				
	5.2	Lift speed laden/unladen	m/s		0.15 / 0.27				
	5.3	Lowering speed laden/unladen	m/s		0.34 / 0.34				
	5.8	Max. gradeability laden/unladen	%		6 / 14				
E-motor/Electronics	6.1	Drive motor, performance S2 60 min	kW		1				
	6.2	Lift motor, performance with S3	kW		2.2				
	6.3	Battery according to DIN 43531/35/36			no				
	6.4	Battery voltage/nominal capacity	V / Ah		24 / 50				
	6.5	Battery weight	kg		24				

	6.6.1	Energy consumption according to EN cycle	kWh/h	0.43
	6.6.2	CO2 equivalent as per EN 16796	kg/h	0.2
Other	10.7	Schalldruckpegel nach EN12053	dB (A)	65.3
<p>- This data sheet according to VDI guideline 2198 only states the technical values of the standard truck. Different tyres, other masts, additional equipment etc. may result in different values.</p>				

- VDI no. 4.34.1: diagonal as per VDI: aisle width + 225 mm; tiller in upright position (slow travel).
- VDI no. 4.34.2: diagonal as per VDI: aisle width + 142 mm; tiller in upright position (slow travel).
- VDI no. 6.2: S3 5%.
- VDI no. 4.35: tiller in upright position (slow travel).

The German production facilities in  
Norderstedt, Moosburg and Landsberg  
are certified as well as our Genuine Parts  
Center in Kaltenkirchen. ISO 9001  
ISO 14001

Jungheinrich fork lift trucks meet  
European safety requirements. 

 **JUNGHEINRICH**