



## **Electric ride-on/pedestrian pallet truck**

### **ERE 120-230**

Lift height: 122 mm / Load capacity: 2000-3000 kg

# ERE 120-230



# ERE 120-230

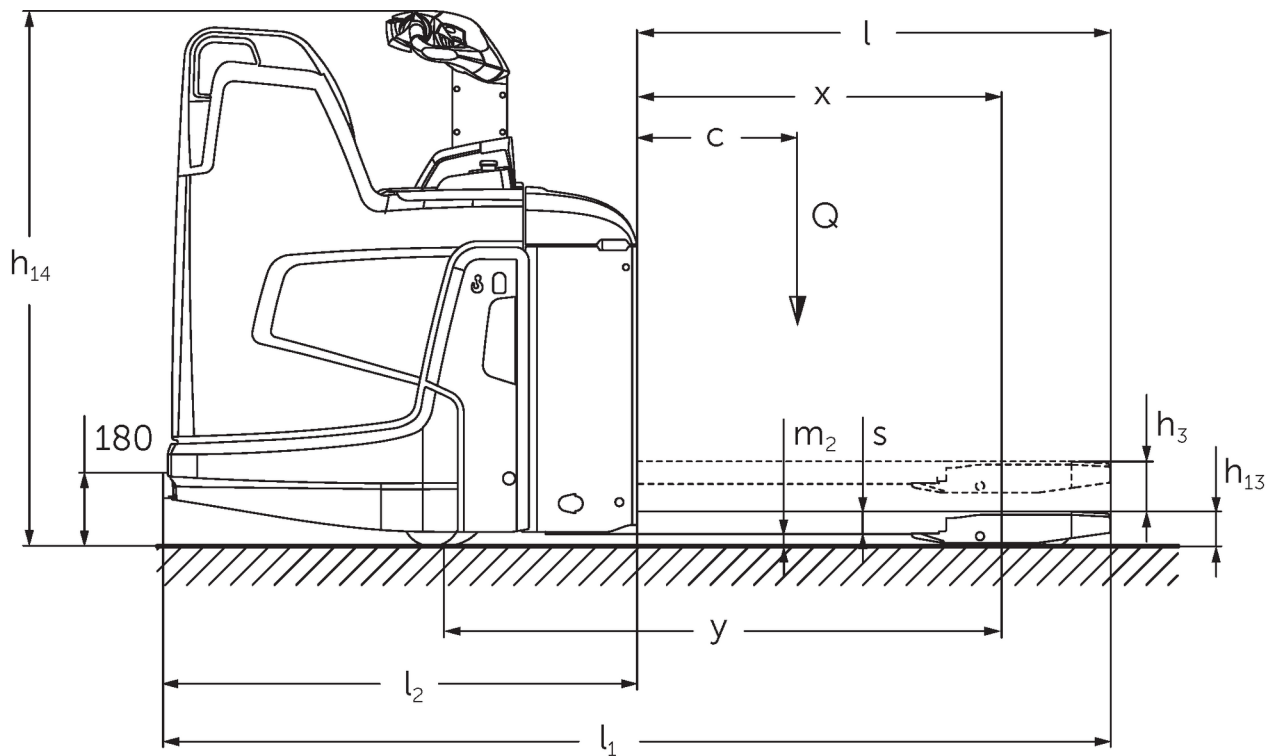

# VDI table

Stand-on: 11/2024

Characteristic	1.1	Manufacturer (abbreviated description)	•	Jungheinrich							
	1.2	Manufacturer's type designation		ERE 120 6km/h	ERE 120 9 km/h	ERE 125	ERE 225	ERE 225 drivePLUS	ERE 230	ERE 230 drivePLUS	
	1.3	Drive		Electric							
	1.4	Operation		Tiller							
	1.5	Load capacity/load	Q kg	2000		2500			3000		
	1.6	Load centre distance	c mm	600							
	1.8	Load distance, centre of drive axle to fork	x mm	908							
	1.9	Wheelbase	y mm	1378					1450		
Weights	2.1	tare weight	kg	400		404			424		
	2.1.1	Service weight (incl. battery)	kg	630		634			721		
	2.2	Axle load laden front/rear	kg	795 / 1825		1126 / 2090			1239 / 2494		
	2.3	Axle load unladen front/rear	kg	474 / 138		550 / 159			565 / 160		
Wheels/suspension system	3.1	Tyres		Vulkollan ®/PU + quartz/Vulkollan ®							
	3.2	Tyre size, front		Ø 230 x 65		Ø 230 x 77					
	3.3	Tyre size, rear		Ø 85 x 110 / Ø 85 x 85					Ø 85 x 85		
	3.4	Additional wheels		Ø 140 x 57							
	3.5	Wheels, number front/back (x=driven)		1x +2/2 oder 4					1x +2/4		
	3.6	Tread width, front	b10 mm	363							
	3.7	Tread width, rear	b11 mm	512							
Basic dimensions	4.4	Lift (h3)	h3 mm	122							
	4.9	Height of tiller handle in drive position min./max.	h14 mm	1137 / 1419							
	4.15	Height, lowered	h13 mm	85							
	4.19	total length	l1 mm	1847		1919					
	4.20	Length including fork shank	l2 mm	697		769					
	4.21.1	total width	b1 mm	770							
	4.22	Fork dimensions	s/ e/l mm	55 x 172 x 1150							
	4.25	Width across forks	b5 mm	535							
	4.32	Ground clearance centre of wheelbase	m2 mm	30							
	4.34.1	Aisle width (pallet 1000x1200 sideways)	Ast mm	2411					2483		
	4.34.2	Aisle width (pallet 800x1200 length)	Ast mm	2299					2372		
	4.34.8	Aisle width (pallet 800x1200 crosswise)	Ast mm	2414					2486		
4.35	Turning radius	Wa mm	1604					1677			
Performance data	5.1	Travel speed laden/unladen	km/h	6 / 6	8 / 9	9 / 9	9.5 / 12.5	9.5 / 14	6 / 12.5	6 / 14	
	5.2	Lift speed laden/unladen	m/s	0.04 / 0.04		0.05 / 0.07					
	5.3	Lowering speed laden/unladen	m/s	0.05 / 0.04		0.05 / 0.05					
	5.8	Max. gradeability laden/unladen	%	5 / 7	8 / 16				6 / 16		
	5.10	Service brake		generative							
E-motor/ Electronics	6.1	Drive motor, performance S2 60 min	kW	2		2.8		3.2		2.8	3.2
	6.2	Lift motor, performance with S3	kW	1.2		2.2					
	6.3	Battery according to DIN 43531/35/36		B	-					B	

	6.4	Battery voltage/nominal capacity	V / Ah	24 / 250					24 / 375	
	6.5	Battery weight	kg	230					297	
	6.6.1	Energy consumption according to EN cycle	kWh/h	0.4	0.43	0.4	0.35	0.39	0.36	0.41
	6.6.2	CO2 equivalent as per EN 16796	kg/h	0.2						
	6.7	Throughput	t/h	114	142	156	184	222	220	266
	6.8.1	Energy consumption with max. throughput	kWh/h	0.74	1.11	1.18	1.29	1.89	1.45	2.05
Other	8.1	Type of drive control		AC						
	10.7	Schalldruckpegel nach EN12053	dB (A)	63		64	67	64	67	
<p>- This data sheet according to VDI guideline 2198 only states the technical values of the standard truck. Different tyres, other masts, additional equipment etc. may result in different values.</p>										

The values in the table apply to the folding stand-on platform (folded up), M-LBE battery compartment, fork length 1,150 mm, raised support arm lift.

- VDI no. 1.8: lowered load section: x + 56 mm.

- VDI no. 1.9: lowered load section: y + 56 mm. With M-VBE, L-LBE & L high-LBE battery compartment: y + 72 mm; L-VBE: y + 125 mm.

- VDI no. 2.1: with lateral battery exchange: + 25 kg.

- VDI no. 4.19: with M-VBE, L-LBE & L high-LBE battery compartment: l1 + 72 mm; L-VBE: l1 + 125 mm. With folding platform folded down: l1 + 416 mm; compact, fixed platform: l1 + 357 mm; extended, fixed platform: l1 + 472 mm; L platform: l1 + 477 mm.

- VDI no. 4.20: with M-VBE, L-LBE & L high-LBE battery compartment: l2 + 72 mm; L-VBE: l2 + 125 mm. With folding platform folded down: l2 + 416 mm; compact, fixed platform: l2 + 357 mm; extended, fixed platform: l2 + 472 mm; L platform: l2 + 477 mm.

- VDI no. 4.34.1: lowered load section: aisle width + 50 mm. with folding platform folded down: aisle width + 416 mm; compact, fixed platform: aisle width + 357 mm; extended, fixed platform: aisle width + 472 mm; L platform: aisle width + 477 mm.

- VDI no. 4.34.2: with folding platform folded down: aisle width + 416 mm; compact, fixed platform: aisle width + 357 mm; extended, fixed platform: aisle width + 472 mm; L platform: aisle width + 477 mm.

- VDI no. 4.34.8: lowered load section: aisle width + 68 mm. with folding platform folded down: aisle width + 416 mm; compact, fixed platform: aisle width + 357 mm; extended, fixed platform: aisle width + 472 mm; L platform: aisle width + 477 mm.

- VDI no. 4.35: lowered load section: Wa + 56 mm.

With M-VBE, L-LBE & L high-LBE battery compartment: Wa + 72 mm; L-VBE: Wa + 125 mm. with folding platform folded down: Wa + 416 mm; compact, fixed platform: Wa + 357 mm; extended, fixed platform: Wa + 472 mm; L platform: Wa + 477 mm.

- VDI no. 5.1: ERE 230: 9.5 km/h with 2.5 t load.

The German production facilities in  
Norderstedt, Moosburg and Landsberg  
are certified as well as our Genuine Parts  
Center in Kaltenkirchen. ISO 9001  
ISO 14001

Jungheinrich fork lift trucks meet  
European safety requirements. 

**JUNGHEINRICH**