



Medium/high level order picker **EKS 110**

Lift height: 1000-2800 mm / Load capacity: 1000 kg

EKS 110

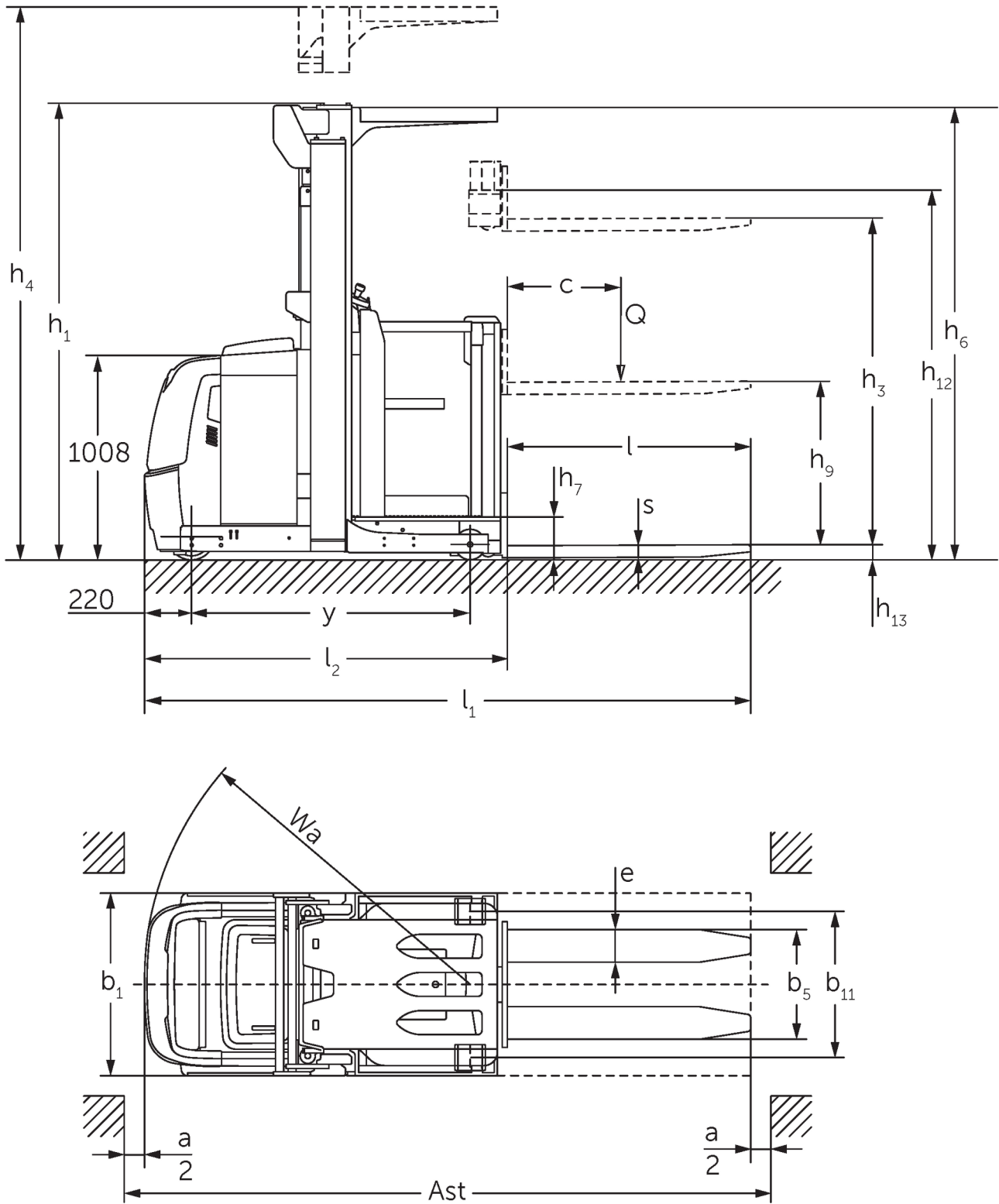
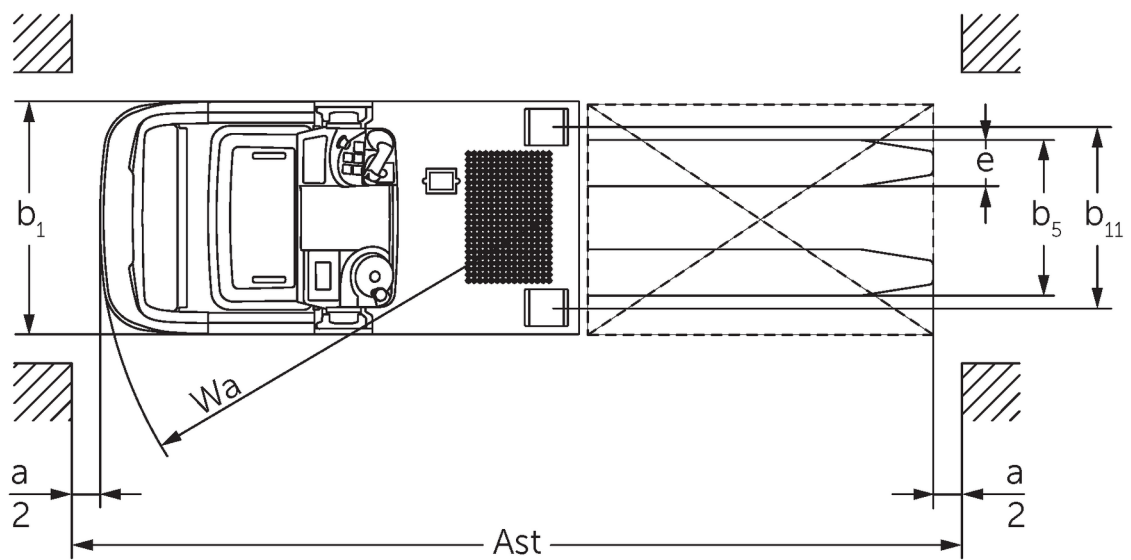
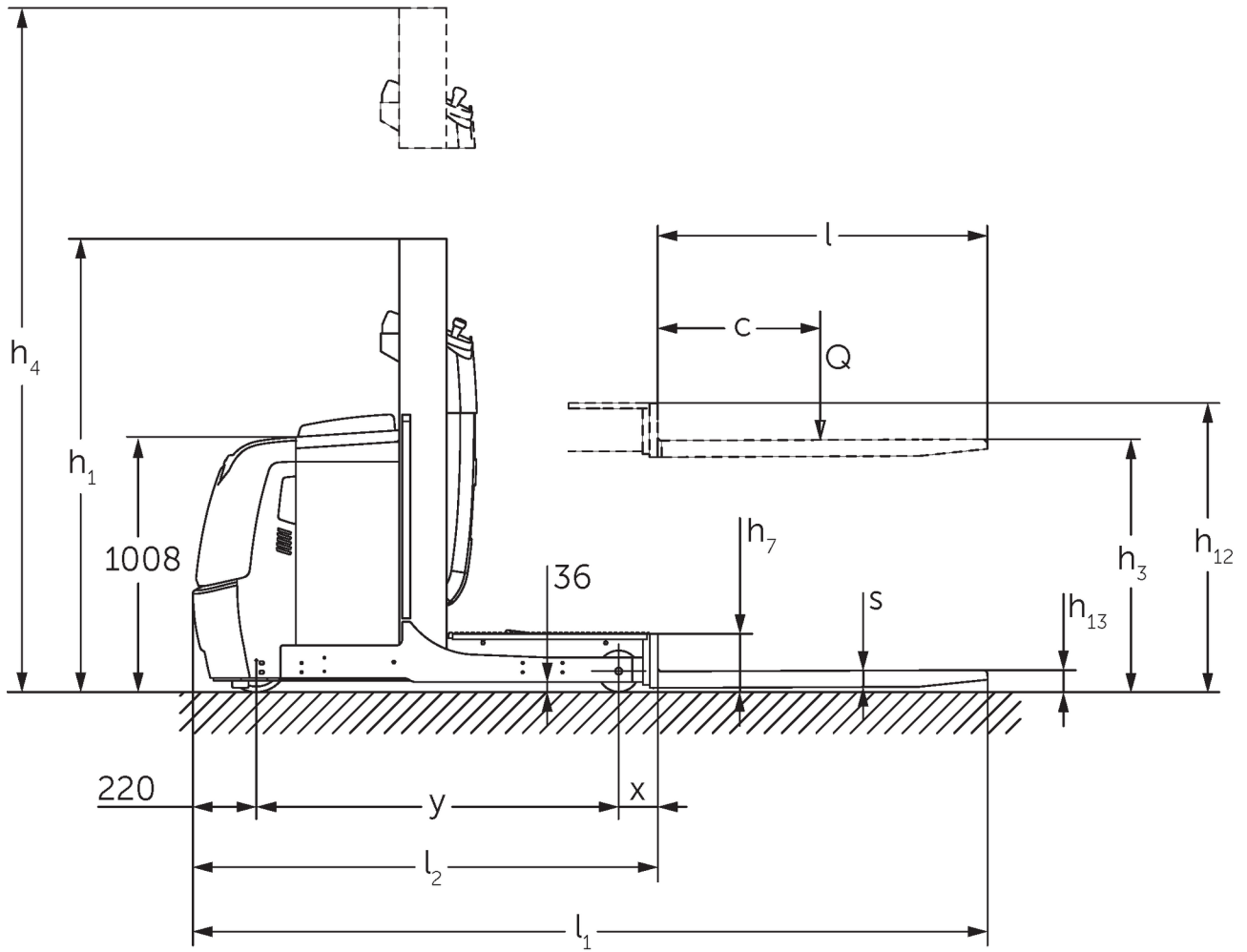

Figure shows EKS 110 Z 280 ZZ

EKS 110



Picture shows EKS 110 L 100 E

VDI table

Stand-on: 12/2024

Characteristic	1.1	Manufacturer (abbreviated description)		Jungheinrich							
	1.2	Manufacturer's type designation		EKS 110 L 100 E	EKS 110 L 160 E	EKS 110 L 190 E	EKS 110 L 280 ZZ	EKS 110 Z 100 E	EKS 110 Z 160 E	EKS 110 Z 190 E	EKS 110 Z 280 ZZ
	1.3	Drive		Electric							
	1.4	Operation		Order pickers							
	1.5	Load capacity/load	Q kg	1000							
	1.6	Load centre distance	c mm	600							
	1.8	Load distance, centre of drive axle to fork	x mm	143		180	148		185		
	1.9	Wheelbase	y mm	1330		1385	1330		1385		
Weights	2.1.1	Service weight (incl. battery)	kg	1661	1785	1813	2268	1763	1907	1953	2390
	2.2	Axle load laden front/rear	kg	491 / 2170	516 / 2269	506 / 2307	762 / 2506	489 / 2274	508 / 2399	504 / 2449	754 / 2636
	2.3	Axle load unladen front/rear	kg	1053 / 608	1093 / 692	1084 / 729	1336 / 932	1062 / 701	1083 / 824	1079 / 874	1328 / 1062
Wheels/suspension system	3.1	Tyres		Vulkollan®							
	3.2	Tyre size, front		ø 230 x 80							
	3.3	Tyre size, rear		ø 150 x 130							
	3.5	Wheels, number front/back (x=driven)		1x / 2							
	3.7	Tread width, rear	b11 mm	630		720	630		720		
Basic dimensions	4.2	Retracted mast height (h1)	h1 mm	1650	2260	2560	2250	1650	2260	2560	2250
	4.4	Lift (h3)	h3 mm	1000	1600	1900	2800	1000	1600	1900	2800
	4.5	Extended mast height (h4)	h4 mm	2650	3830	4130	5030	2650	3830	4130	5030
	4.7	Height of overhead guard (cab)	h6 mm	-	2230		-	2230			
	4.8.1	Stand height	h7 mm	200							
	4.11	Additional lift	h9 mm	-				800			
	4.14	Stand height, elevated	h12 mm	1200	1800	2100	3000	1200	1800	2100	3000
	4.15	Height, lowered	h13 mm	80							
	4.19	Overall length	l1 mm	2890		2980	2895		2985		
	4.20	Length including fork shank	l2 mm	1690		1780	1695		1785		
	4.21.1	Overall width	b1 mm	810		900	810		900		
	4.22	Fork dimensions	s/e/l mm	60 x 160 x 1200							
	4.25	Width across forks	b5 mm	540							
	4.26	Width between support arms/loading areas	b4 mm	430		520	430		520		
	4.27	Width over guide rollers	b6 mm	970		1060	970		1060		
4.31	Ground clearance laden under mast	m1 mm	35								
4.34.1	Aisle width (pallet 1000x1200 sideways)	Ast mm	3039		3127	3039		3127			
4.34.2	Aisle width (pallet 800x1200 length)	Ast mm	3149		3240	3154		3245			
4.35	Turning radius	Wa mm	1548		1603	1548		1603			
Performance data	5.1	Travel speed laden/unladen (Efficiency drivePLUS)	km/h	9 / 10 10 / 13	9 / 9 10 / 12	9 / 9 9.5 / 12	9 / 9 9 / 11	9 / 10 10 / 13	9 / 9 10 / 12	9 / 9 9.5 / 12	9 / 9 9 / 11

	5.2	Lift speed laden/ unladen	m/s	0.19 / 0.26	0.15 / 0.2	0.23 / 0.31	0.19 / 0.26	0.15 / 0.2	0.23 / 0.31
	5.3	Lowering speed laden/ unladen	m/s	0.24 / 0.24	0.23 / 0.22	0.28 / 0.26	0.24 / 0.24	0.23 / 0.22	0.28 / 0.26
	5.7	Gradeability laden/ unladen	%	5 / 10					
	5.10	Service brake		generative					
	5.11	Parking brake		Electromagnetic spring-loaded brake system					
E-motor/Electronics	6.1	Drive motor, performance S2 60 min	kW	3.2					
	6.2	Lift motor, performance with S3	kW	3	6	3	6		
	6.3	Battery according to DIN 43531/35/36		DIN 43535 B					
	6.4	Battery voltage/nominal capacity	V / Ah	24 / 620					
	6.5	Battery weight	kg	480					
Other	8.1	Type of drive control		AC					
	10.5	Steering version		Electric power steering					
	10.7	Sound level as per EN12053, operator's ear	dB (A)	61					

- This data sheet according to VDI guideline 2198 only states the technical values of the standard truck. Different tyres, other masts, additional equipment etc. may result in different values.

- 4.2: L100E with overhead guard 2,230 mm
- 4.5: L100E with overhead guard 3,230 mm
- 4.7: L100E and Z100E overhead guard optional

The German production facilities in
Norderstedt, Moosburg and Landsberg
are certified as well as our Genuine Parts
Center in Kaltenkirchen. ISO 9001
ISO 14001

Jungheinrich fork lift trucks meet
European safety requirements. 

 **JUNGHEINRICH**