

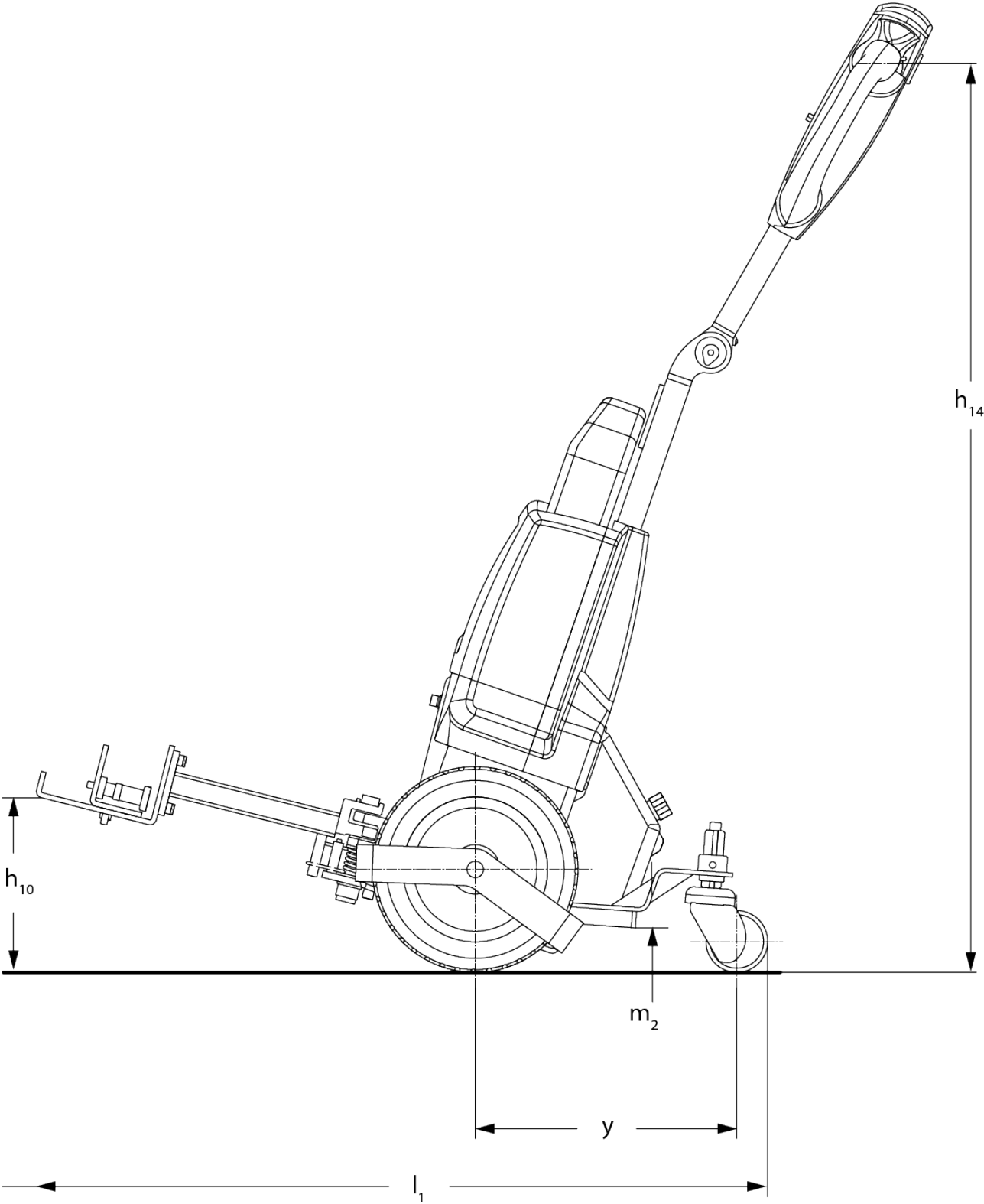

**Electric tow tractor**  
**EZS 010**

# EZS 010



EZS 010

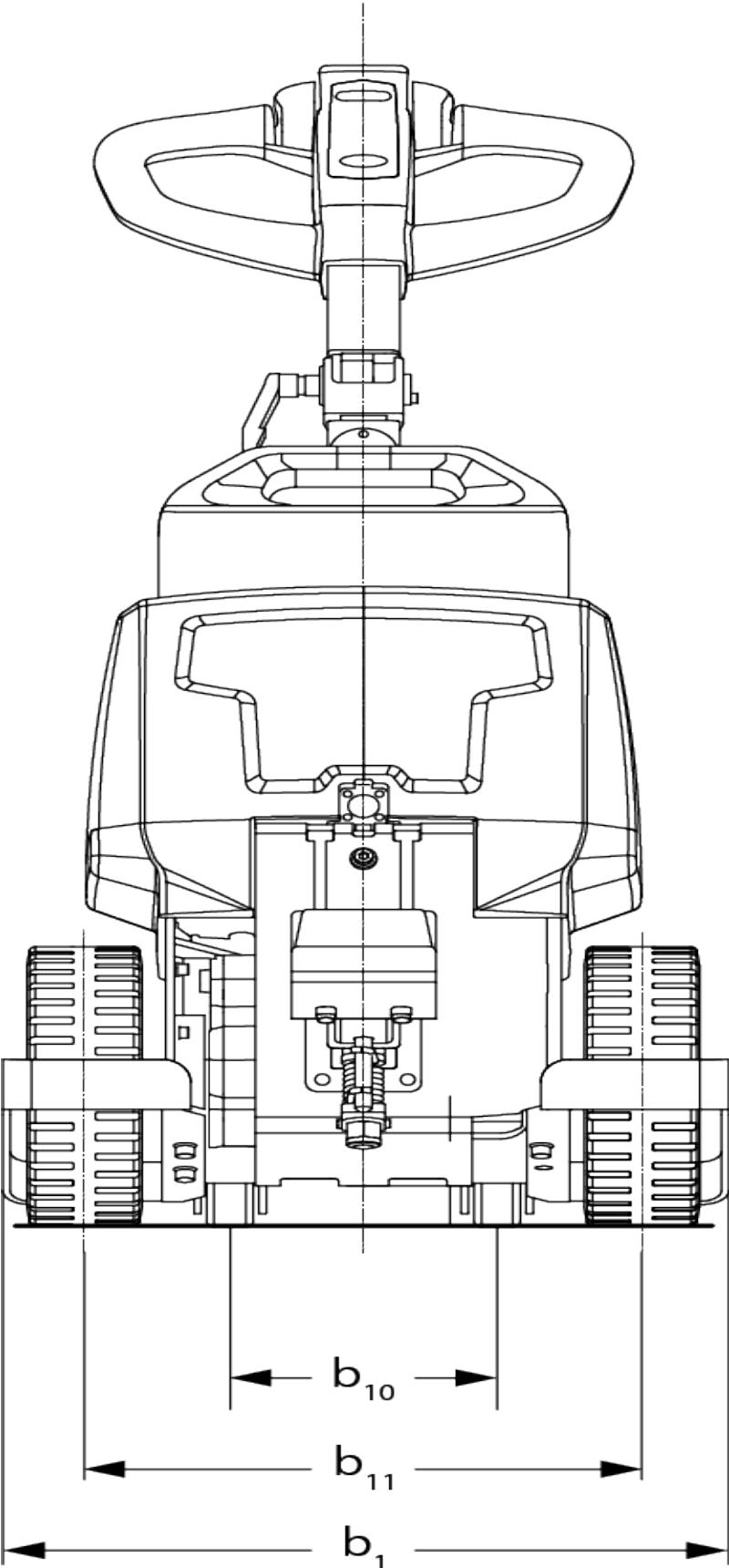

# EZS 010

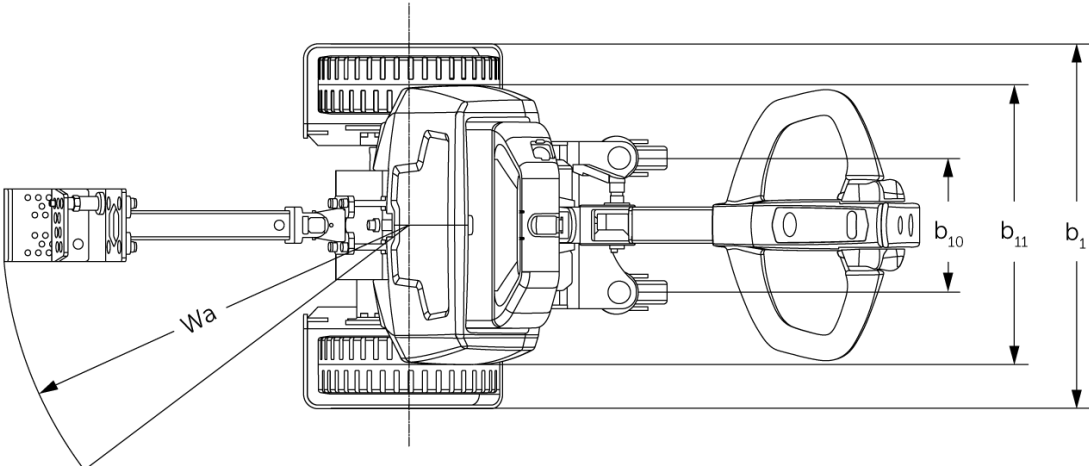

# VDI table

Stand-on: 12/2024

Characteristic	1.1	Manufacturer (abbreviated description)			Jungheinrich
	1.2	Manufacturer's type designation			<b>EZS 010</b>
	1.3	Drive			Electric
	1.4	Operation			Pedestrian
	1.5.3	Towing capacity	Q	kg	1000
	1.7	Rated drawbar pull		N	200
	1.9	Wheelbase	y	mm	325
Weights	2.1	tare weight		kg	67
	2.3	Axle load unladen front/rear		kg	55 / 19
Wheels/suspension system	3.2	Tyre size, front			250x80
	3.3	Tyre size, rear			75x32
	3.5	Wheels, number front/back (x=driven)			2x+2/-
	3.6	Tread width, front	b10	mm	185
	3.7	Tread width, rear	b11	mm	385
Basic dimensions	4.9	Height of tiller handle in drive position min./max.	h14	mm	750 / 1150
	4.19	Overall length	l1	mm	915
	4.21.1	Overall width	b1	mm	503
	4.32	Ground clearance centre of wheelbase	m2	mm	35
	4.35	Turning radius	Wa	mm	560
Performance data	5.1	Travel speed laden/unladen		km/h	4.5 / 4.9
	5.5	Drawbar pull laden		N	200
	5.6	Max. drawbar pull laden/unladen		N / -	550 / -
	5.10	Service brake			electromagnetic
E-motor/ Electronics	6.1	Drive motor, performance S2 60 min		kW	0.4
	6.4	Battery voltage/nominal capacity		V / Ah	24 / 36
	6.5	Battery weight		kg	7.5
	6.6.1	Energy consumption according to EN cycle		kWh/h	0.18
	6.6.2	CO2 equivalent as per EN 16796		kg/h	0.1
Other	8.1	Type of drive control			Impulse/DC
	10.7	Sound level as per EN12053, operator's ear		dB (A)	70

- This data sheet according to VDI guideline 2198 only states the technical values of the standard truck. Different tyres, other masts, additional equipment etc. may result in different values.

The German production facilities in  
Norderstedt, Moosburg and Landsberg  
are certified as well as our Genuine Parts  
Center in Kaltenkirchen. ISO 9001  
ISO 14001

Jungheinrich fork lift trucks meet  
European safety requirements. 

 **JUNGHEINRICH**