

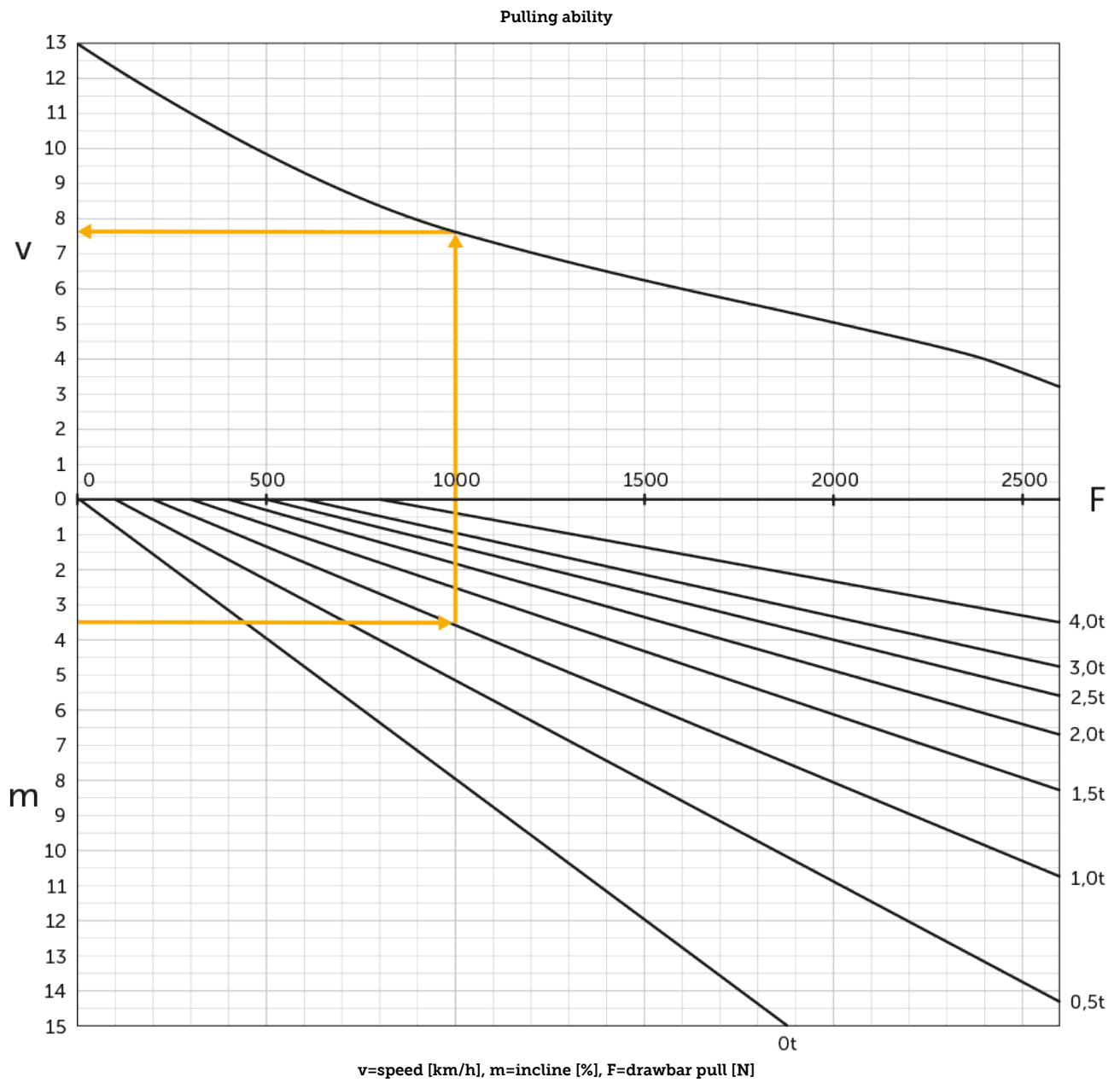

Electric tow tractor **EZS C40**

EZS C40



EZS C40

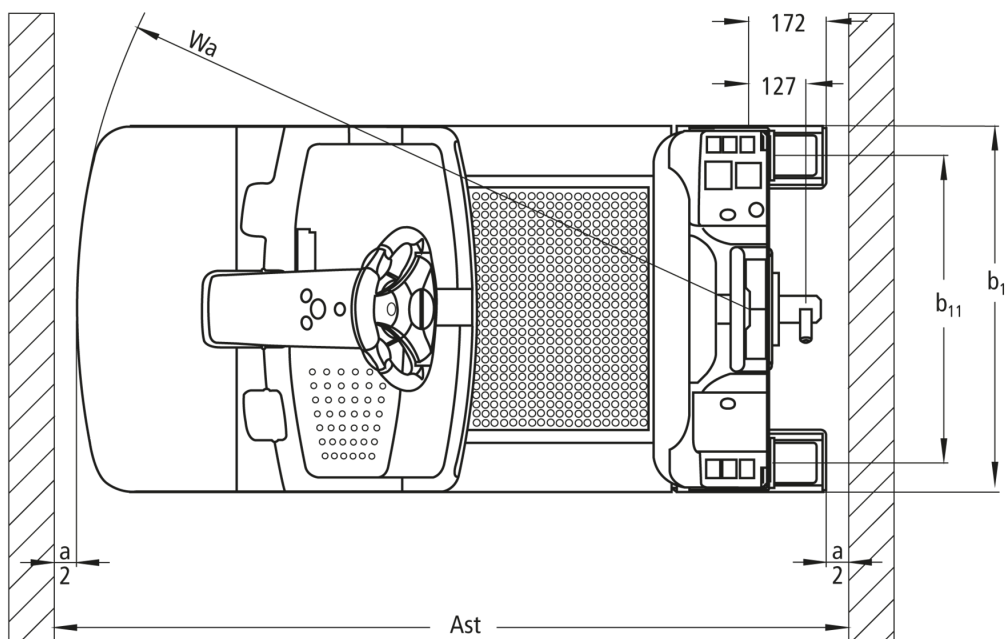

VDI table

Stand-on: 12/2024

Characteristic	1.1	Manufacturer (abbreviated description)			Jungheinrich
	1.2	Manufacturer's type designation			EZS C40
	1.3	Drive			Electric
	1.4	Operation			Stand-on
	1.5.3	Towing capacity	Q	kg	4000
	1.7	Rated drawbar pull		N	800
	1.9	Wheelbase	y	mm	1229
Weights	2.1.1	Service weight (incl. battery)		kg	1185
	2.3	Axle load unladen front/rear		kg	660 / 525
Wheels/suspension system	3.1	Tyres			Super-elastic (SE)
	3.2	Tyre size, front			Ø 310 x 105
	3.3	Tyre size, rear			Ø 301 x 85
	3.5	Wheels, number front/back (x=driven)			1x / 2
	3.7	Tread width, rear	b11	mm	680
Basic dimensions	4.8	Seat height/stand height	h7	mm	182
	4.9	Height of tiller handle in drive position min./max.	h14	mm	1410
	4.12	Coupling height	h10	mm	158
	4.19	Overall length	l1	mm	1659
	4.21.1	Overall width	b1	mm	810
	4.32	Ground clearance centre of wheelbase	m2	mm	100
	4.35	Turning radius	Wa	mm	1487
Performance data	5.1	Travel speed laden/unladen		km/h	8 / 12.5
	5.1.1	Reverse travel speed with/without load		km/h	6 / 6
	5.5	Drawbar pull laden		N	800
	5.6	Max. drawbar pull laden/unladen		N	2600 / 2600
	5.10	Service brake			generative
E-motor/ Electronics	6.1	Drive motor, performance S2 60 min		kW	2.8
	6.4	Battery voltage/nominal capacity		V / Ah	24 / 620
	6.5	Battery weight		kg	470
	6.6.1	Energy consumption according to EN cycle		kWh/h	1.13
	6.6.2	CO2 equivalent as per EN 16796		kg/h	0.6
Other	8.1	Type of drive control			AC speedCONTROL
	10.5	Steering version			Electric steering
	10.7	Sound level as per EN12053, operator's ear		dB (A)	66

- This data sheet according to VDI guideline 2198 only states the technical values of the standard truck. Different tyres, other masts, additional equipment etc. may result in different values.

- VDI no. 4.9: the height applies to the jetPILOT
- VDI no. 4.12: the value for the coupling height applies to a single plug-in coupling. Other coupling heights are available
- VDI no. 4.19: as different coupling systems are available, the specification applies to the overall length including a single plug-in coupling
- VDI no. 5.1: see tow load diagram
- VDI no. 5.5: this value is the rated drawbar pull
- VDI no. 5.6: see tow load diagram

The German production facilities in
Norderstedt, Moosburg and Landsberg
are certified as well as our Genuine Parts
Center in Kaltenkirchen. ISO 9001
ISO 14001

Jungheinrich fork lift trucks meet
European safety requirements. 

**JUNGHEINRICH**