

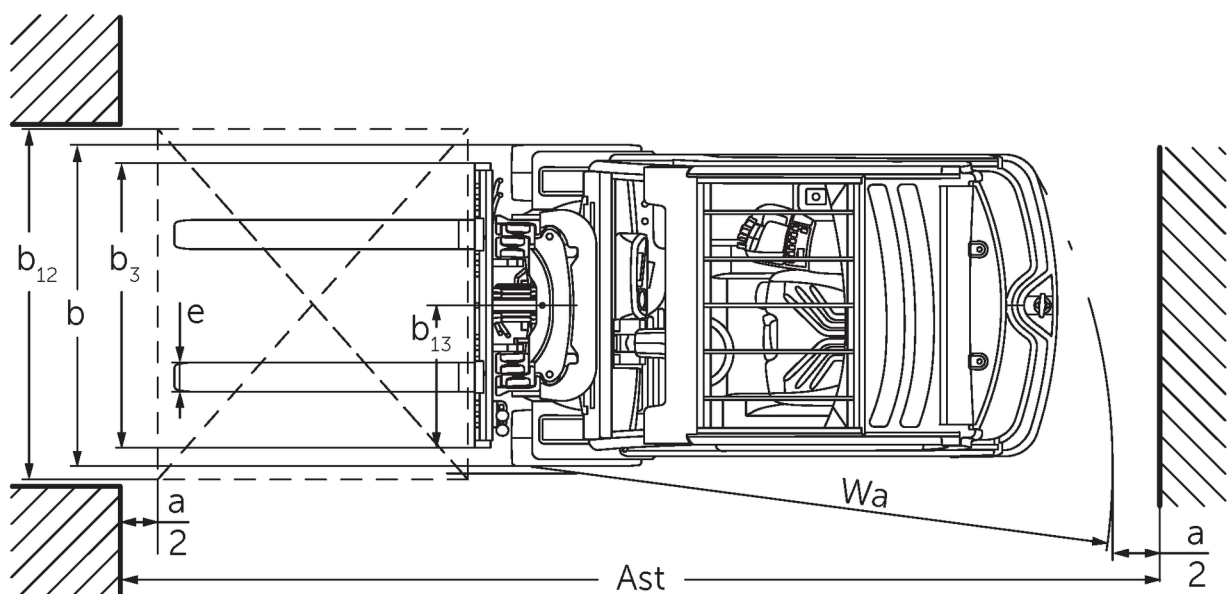

## **Elektrische driewielheftruck** **EFG 213-220**

Hefhoogte: 2020-7000 mm / Capaciteit: 1300-2000 kg

# EFG 213-220



# EFG 213-220

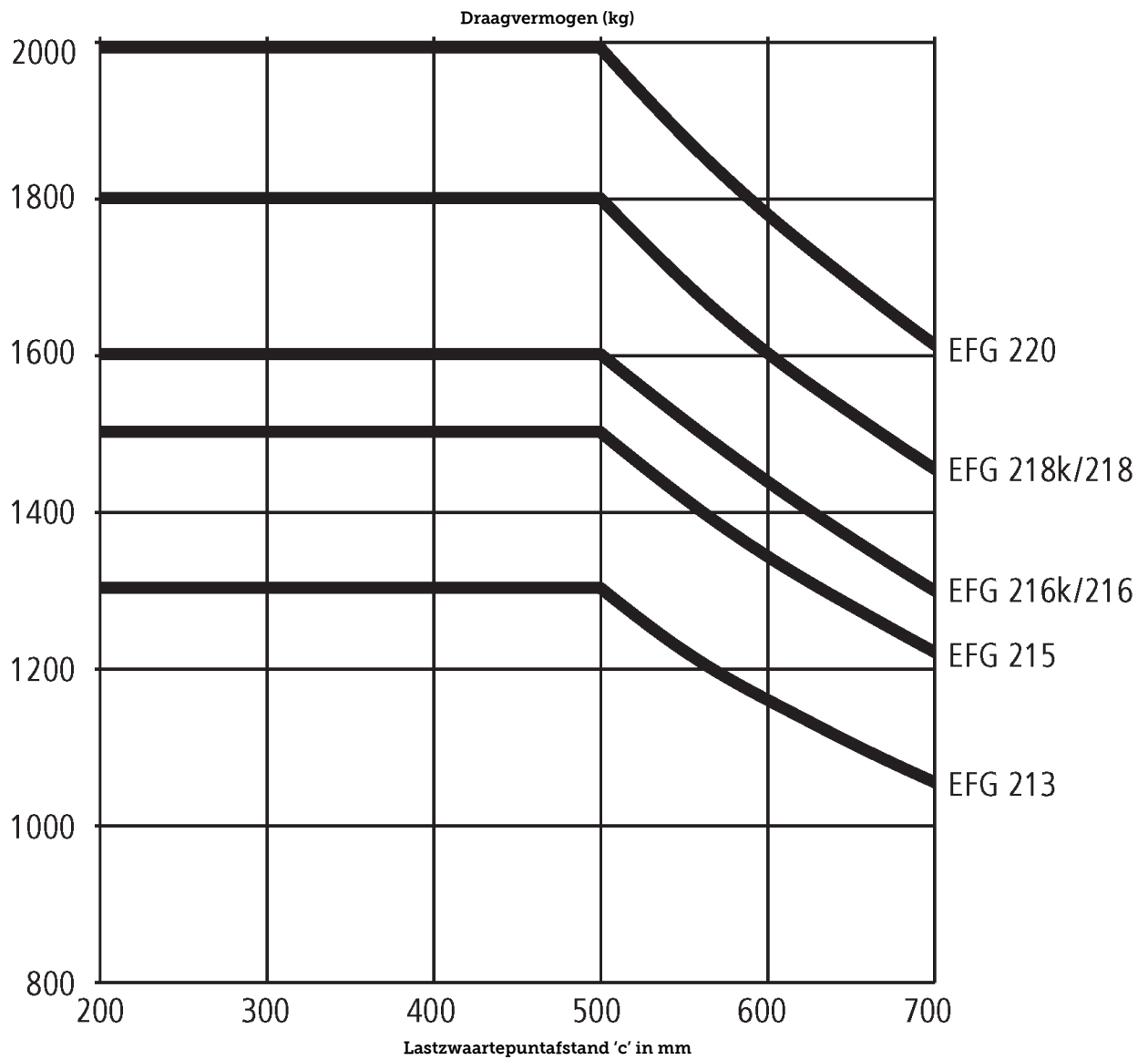

# EFG 213-220

EFG 213, EFG 215, EFG 216k, EFG 216	Heffing (h3)	Ingeschoven masthoogte (h1)	Vrije heffing (h2)	Uitgeschoven masthoogte (h4)	Neiging mast voorover/achterover
Drievoudige mast DZ	<b>4250 mm</b>	<b>1975 mm</b>	<b>1385 mm</b>	<b>4840 mm</b>	<b>7 / 4 °</b>
	4400 mm	2025 mm	1435 mm	4990 mm	7 / 4 °
	4640 mm	2105 mm	1515 mm	5230 mm	7 / 5 °
	4700 mm	2125 mm	1535 mm	5290 mm	7 / 5 °
	4800 mm	2165 mm	1575 mm	5390 mm	7 / 5 °
	5000 mm	2235 mm	1645 mm	5590 mm	7 / 5 °
	5500 mm	2415 mm	1825 mm	6090 mm	7 / 5 °
	6000 mm	2585 mm	1995 mm	6590 mm	7 / 5 °
	6500 mm	2765 mm	2175 mm	7090 mm	7 / 5 °
	7000 mm	2935 mm	2345 mm	7590 mm	7 / 5 °
Tweevoudige mast ZT	<b>3000 mm</b>	<b>2060 mm</b>	<b>150 mm</b>	<b>3590 mm</b>	<b>7 / 6 °</b>
	3100 mm	2110 mm	150 mm	3690 mm	7 / 6 °
	3300 mm	2210 mm	150 mm	3890 mm	7 / 7 °
	3500 mm	2310 mm	150 mm	4090 mm	7 / 7 °
	3700 mm	2410 mm	150 mm	4290 mm	7 / 7 °
	4000 mm	2560 mm	150 mm	4590 mm	7 / 7 °
	4500 mm	2810 mm	150 mm	5090 mm	7 / 7 °
Tweevoudige mast ZZ	<b>2900 mm</b>	<b>1965 mm</b>	<b>1375 mm</b>	<b>3490 mm</b>	<b>7 / 6 °</b>
	3100 mm	2065 mm	1475 mm	3690 mm	7 / 6 °
	3180 mm	2105 mm	1515 mm	3770 mm	7 / 7 °
	3300 mm	2165 mm	1575 mm	3890 mm	7 / 7 °
	3500 mm	2265 mm	1675 mm	4090 mm	7 / 7 °
	3700 mm	2365 mm	1775 mm	4290 mm	7 / 7 °
	4000 mm	2515 mm	1925 mm	4590 mm	7 / 7 °
EFG 218k, EFG 218, EFG 220	Heffing (h3)	Ingeschoven masthoogte (h1)	Vrije heffing (h2)	Uitgeschoven masthoogte (h4)	Neiging mast voorover/achterover
Drievoudige mast DZ	<b>4250 mm</b>	<b>1982 mm</b>	<b>1340 mm</b>	<b>4892 mm</b>	<b>7 / 6 °</b>
	4400 mm	2032 mm	1390 mm	5042 mm	7 / 6 °
	4640 mm	2112 mm	1470 mm	5282 mm	7 / 5 °
	4700 mm	2132 mm	1490 mm	5342 mm	7 / 5 °
	4800 mm	2172 mm	1530 mm	5442 mm	7 / 5 °
	5000 mm	2242 mm	1600 mm	5642 mm	7 / 5 °
	5500 mm	2422 mm	1780 mm	6142 mm	7 / 5 °
	6000 mm	2592 mm	1950 mm	6642 mm	7 / 5 °
	6500 mm	2772 mm	2130 mm	7142 mm	7 / 5 °
	7000 mm	2942 mm	2300 mm	7642 mm	7 / 5 °
Tweevoudige mast ZT	<b>2020 mm</b>	<b>1577 mm</b>	<b>150 mm</b>	<b>2632 mm</b>	<b>7 / 5 °</b>
	3000 mm	2067 mm	150 mm	3612 mm	7 / 6 °
	3100 mm	2117 mm	150 mm	3712 mm	7 / 6 °
	3300 mm	2217 mm	150 mm	3912 mm	7 / 7 °
	3500 mm	2317 mm	150 mm	4112 mm	7 / 7 °
	3700 mm	2417 mm	150 mm	4312 mm	7 / 7 °
	4000 mm	2567 mm	150 mm	4612 mm	7 / 7 °
	4500 mm	2817 mm	150 mm	5112 mm	7 / 7 °
Tweevoudige mast ZZ	<b>2900 mm</b>	<b>1972 mm</b>	<b>1330 mm</b>	<b>3542 mm</b>	<b>7 / 6 °</b>

3100 mm	2072 mm	1430 mm	3742 mm	7 / 6 °
3180 mm	2112 mm	1470 mm	3822 mm	7 / 7 °
3300 mm	2172 mm	1530 mm	3942 mm	7 / 7 °
3500 mm	2272 mm	1630 mm	4142 mm	7 / 7 °
3700 mm	2372 mm	1730 mm	4342 mm	7 / 7 °
4000 mm	2522 mm	1880 mm	4642 mm	7 / 7 °

# VDI-tabel

Stand: 12/2024

Kenmerken	1.2	Typeaanduiding fabrikant		EFG 213	EFG 215	EFG 216k	EFG 216	EFG 218k	EFG 218	EFG 220	
	1.3	Aandrijving		Elektrisch							
	1.4	Bediening		Stoel							
	1.5	Capaciteit/last	Q kg	1300	1500	1600	1800	2000			
	1.6	Lastzwaartepuntafstand	c mm	500							
	1.8	Lastafstand	x mm	344				364			
	1.9	Wielbasis	y mm	1249	1357	1465	1357	1465			
	Gewichten	2.1.1	Eigen gewicht (incl. accu)	kg	2692	2937	2959	3018	3240	3191	3366
		2.2	Aslast met last voor/achter	kg	3534 / 458	3860 / 577	4043 / 516	4050 / 566	4457 / 583	4477 / 514	4784 / 582
2.3		Aslast onbelast voor/achter	kg	1307 / 1385	1290 / 1647	1392 / 1567	1479 / 1539	1403 / 1817	1534 / 1657	1514 / 1852	
Wielen/chassis	3.1	Banden		SuperElastik (SE)							
	3.2	Bandenmaat, voor		18 x 7-8				200 / 50-10			
	3.3	Bandenmaat, achter		140 / 55-9							
	3.5	Wielen, aantal voor/achter (x = aangedreven)		2x/2							
	3.6	Spoorbreedte, voor	b10 mm	904				914			
	3.7	Spoorbreedte, achter	b11 mm	176							
	Afmetingen	4.1	Neiging mast voorover/achterover	a/β °	7 / 6						
4.2		Ingeschoven masthoogte (h1)	h1 mm	2060				2067			
4.3		Vrije heffing (h2)	h2 mm	150							
4.4		Heffing (h3)	h3 mm	3000							
4.5		Uitgeschoven masthoogte (h4)	h4 mm	3590				3612			
4.7		Hoogte beschermend dak (cabine)	h6 mm	2040							
4.8		Zithoogte / stahoogte	h7 mm	920							
4.12		Koppelingshoogte	h10 mm	560							
4.19		Totale lengte	l1 mm	2933	3041	3149	3061	3169			
4.20		Lengte inclusief vorkrug	l2 mm	1783	1891	1999	1911	2019			
4.21.1		Totale breedte	b1 mm	1060				1120			
4.22		Vorkafmetingen	s/e/l mm	40 x 80 x 1150							40 x 100 x 1150
4.23		Vorkenbord aansluitklasse		2A							
4.24		Breedte vorkenbord	b3 mm	980							
4.31		Bodemvrijheid met last onder hefmast	m1 mm	97				105			
4.32		Bodemvrijheid midden wielbasis	m2 mm	100							
4.34.1		Werkbreedte (pallet 1000 x 1200 dwars)	Ast mm	3112	3220	3327	3238	3345			
4.34.2		Werkbreedte (pallet 800x1200 longitudinaal)	Ast mm	3235	3343	3450	3362	3469			
4.35		Draaicirkel	Wa mm	1440	1548	1655	1548	1655			
4.36	Kleinste draaipuntafstand	b13 mm	0								
Prestaties	5.1	Rijsnelheid met last/onbelast	km/u	16 / 16							
	5.2	Hefsnelheid met last/onbelast	m/s	0,51 / 0,74				0,46 / 0,74		0,45 / 0,63	
	5.3	Daalsnelheid met last/onbelast	m/s	0,55 / 0,55							
	5.5	Trekkracht met last	N	2300	2200	2150	2100	2000		1900	
	5.6	Max. trekkracht met last/onbelast	N	13000 / 11100	13000 / 10900	13000 / 12000	13000 / 12600	12500 / 12100	12500 / 12500	12300 / 12000	

	5.7	Nominale helling met last/ onbelast	%	7,6 / 12,5	7,3 / 12,3		7 / 11,5	6,2 / 10,7	5,9 / 10,5	5,7 / 10,4
	5.8	Max. helling met last/onbelast	%	28 / 31	27 / 28	27 / 31	27 / 33	25 / 29	25 / 31	24 / 30
	5.9	Acceleratietijd met last/onbelast	s	5,5 / 5,1	5,6 / 5,2	5,7 / 5,2		5,8 / 5,3		5,9 / 5,3
	5.10	Rem		elektrisch/mechanisch						
E-motor/elektronica	6.1	Rijmotor, vermogen S2 60 min	kW	4,5						
	6.1.1	2. Rijmotor, vermogen S2 60 min	kW	4,5						
	6.2	Hefmotor, vermogen bij S3	kW	11,5						
	6.3	Accu volgens DIN 43531/35/36		DIN 43531 A						
	6.4	Accuspanning/nominaal vermogen	V / Ah	48 / 500	48 / 625	48 / 750	48 / 625	48 / 750		
	6.5	Accugewicht	kg	715	855	1025	855	1025		
	6.6.1	Energieverbruik volgens EN- cyclus	kWh/u	3,5	3,7	3,9		4,1		4,5
	6.6.2	CO2-equivalent volgens EN16796	kg/h	1,9	2	2,1		2,2		2,4
	6.7	Omslag	t/h	105	111	113		126		140
	6.8.1	Energieverbruik bij max. omslag	kWh/u	4,7	4,8	4,9		5,4		5,5
Overig	8.1	Type rijregeling		Impuls/AC						
	10.1	Werkdruk voor aanbouwapparaat	bar	230						
	10.2	Oliestroom voor aانبouwapparatuur	l/min	27						
	10.7	Schalldruckpegel nach EN12053	dB (A)	67						
	10.8	Trekhaak, type / type DIN		DIN 15170 H						
- Dit typeblad volgens VDI-richtlijn 2198 noemt alleen de technische waarden van de standaardmachine. Afwijkende banden, andere hefmasten, extra systemen etc. kunnen resulteren in andere waarden.										

- 6.6.1: 60 cycli / uur

De Duitse fabrieken in Norderstedt,  
Moosburg en Landsberg zijn  
gecertificeerd, evenals ons  
onderdelenmagazijn in Kaltenkirchen.

ISO 9001  
ISO 14001

Jungheinrich intern transport materieel  
voldoet aan de Europese  
veiligheidsvoorschriften.



 **JUNGHEINRICH**

The logo features a red upward-pointing arrow integrated into the letter 'J' of the word 'JUNGHEINRICH', which is written in a bold, black, sans-serif font.