

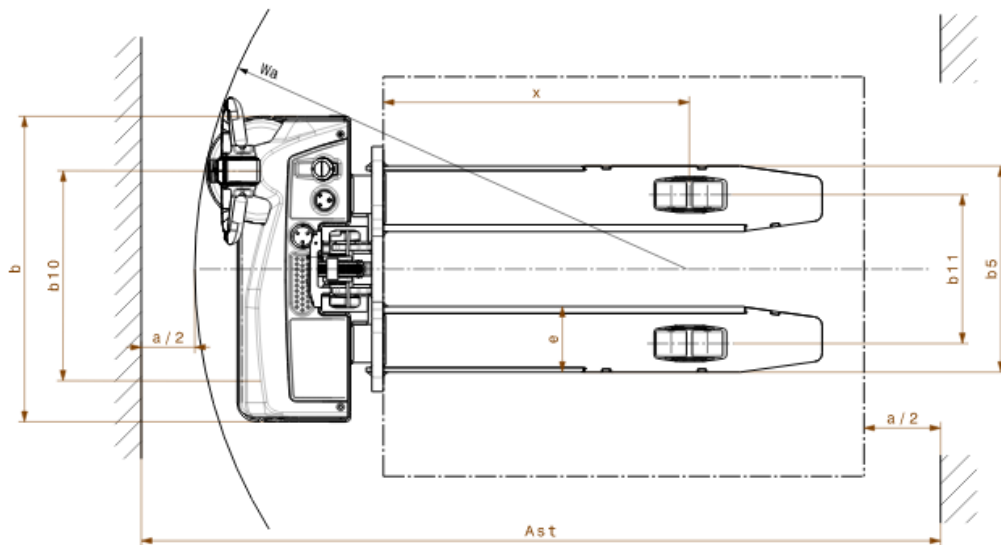

Electric pedestrian stacker **EJC BA 110 / B10 E**

Load capacity: 1000 kg

EJC BA 110 / B10 E

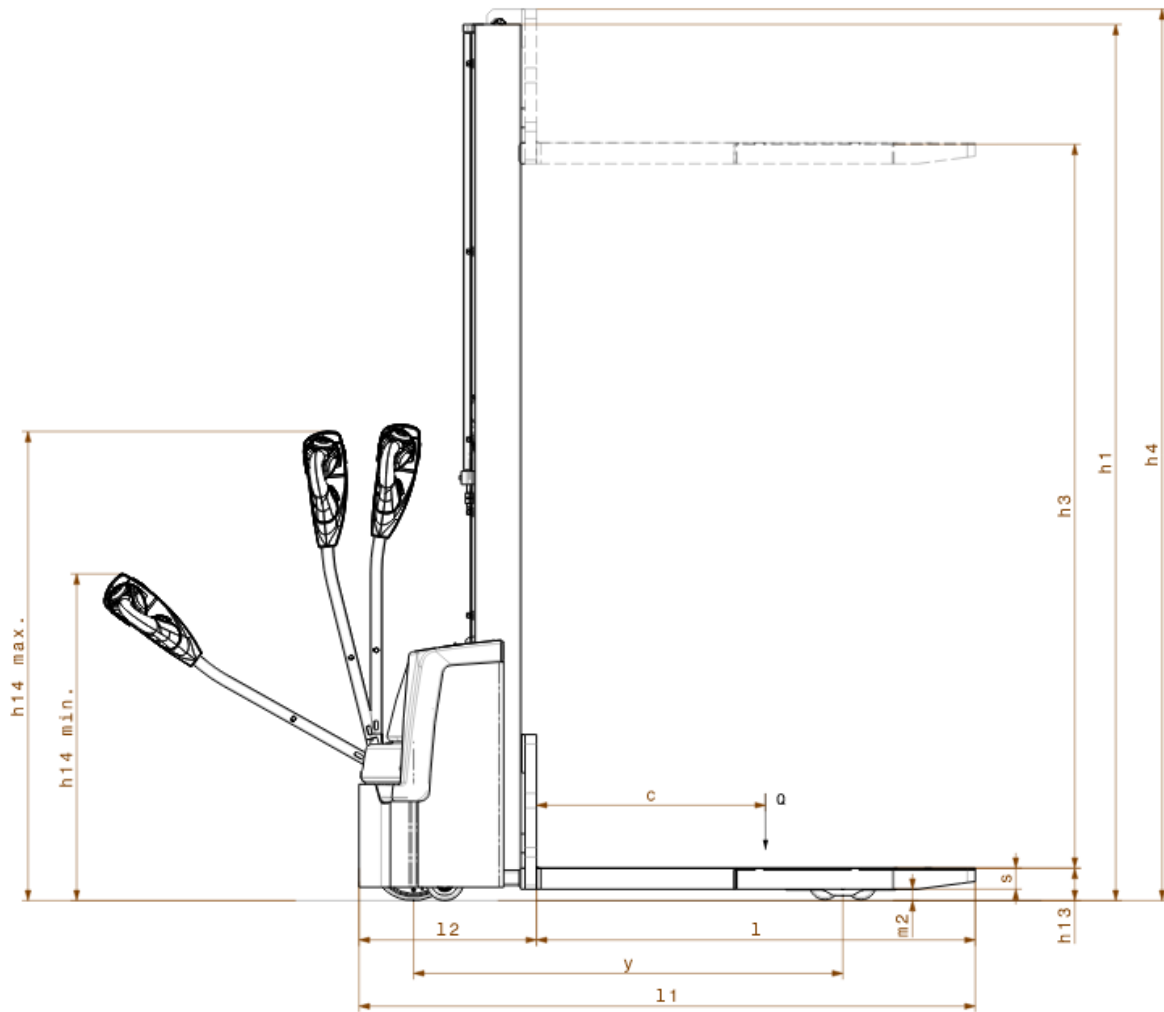

EJC BA 110 / B10 E

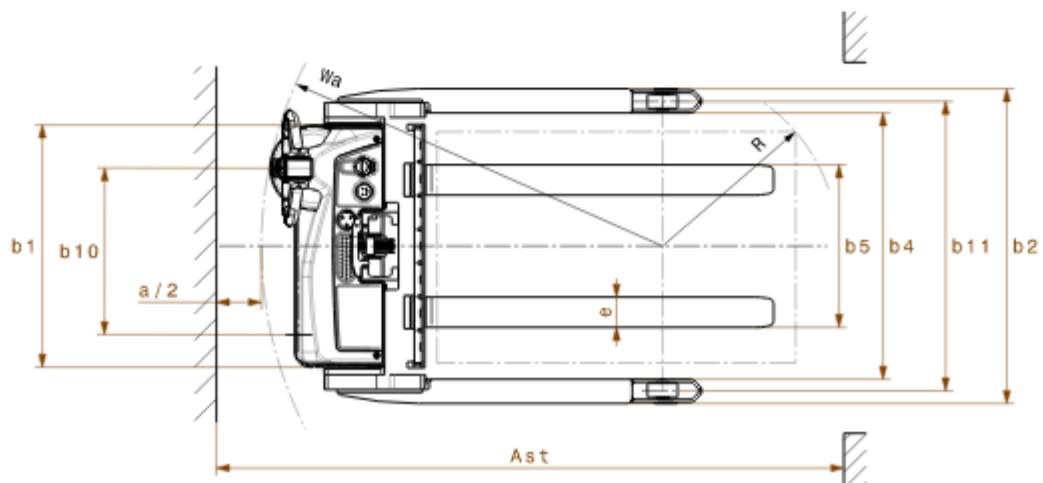
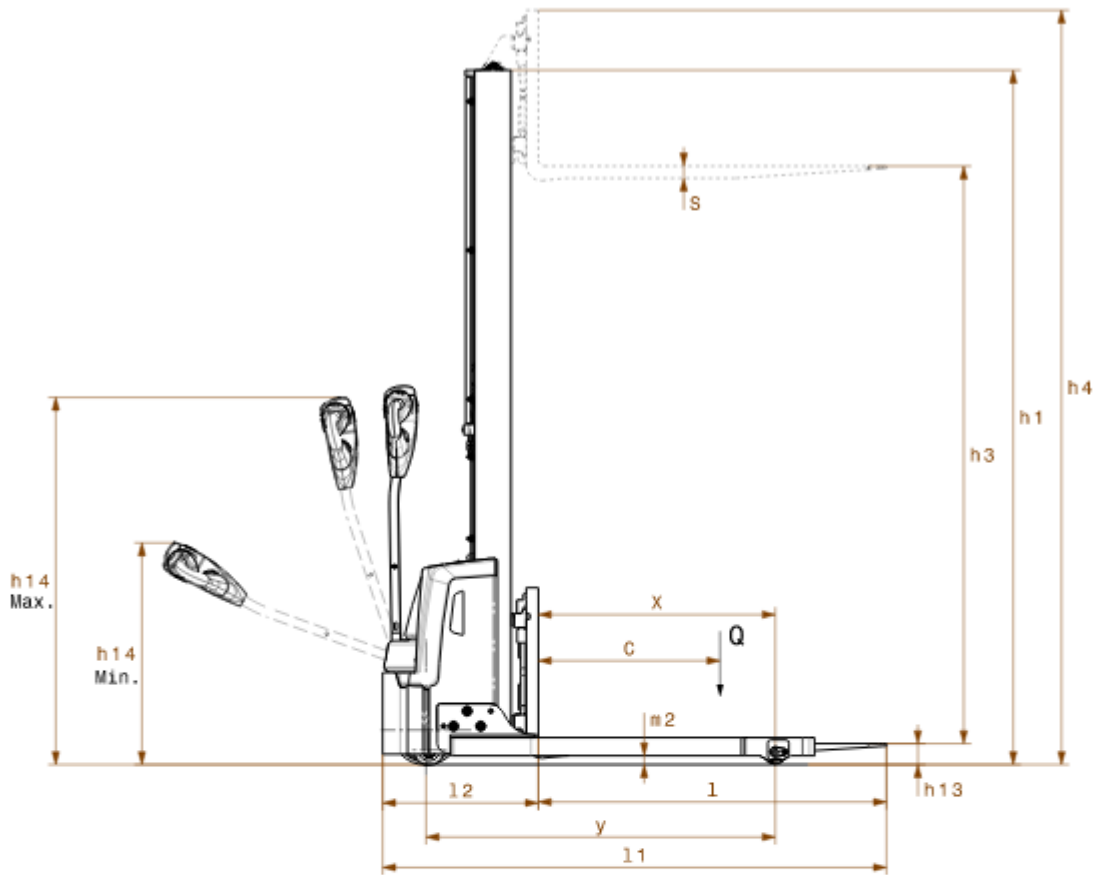

EJC BA 110 / B10 E

EJC BA 110 E, EJC BA B10 E	Lift (h3)	Retracted mast height (h1)	Free lift (h2)	Extended mast height (h4)
Single mast E	1540 mm	1935 mm	100 mm	1975 mm
	1900 mm	2295 mm	100 mm	2335 mm

VDI table

Stand-on: 12/2024

Characteristic	Item	Description	Unit	Jungheinrich	
				EJC BA 110 E	EJC BA B10 E
Characteristic	1.1	Manufacturer (abbreviated description)		Jungheinrich	
	1.2	Manufacturer's type designation		EJC BA 110 E	EJC BA B10 E
	1.3	Drive		Electric	
	1.4	Operation		Pedestrian	
	1.5	Load capacity/load	Q kg	1000	
	1.6	Load centre distance	c mm	600	
	1.8	Load distance, centre of drive axle to fork	x mm	803	783
	1.9	Wheelbase	y mm	1125	1154
	Weights	2.1.1	Service weight (incl. battery)	kg	460
2.2		Axle load laden front/rear	kg	622 / 838	560 / 1042
2.3		Axle load unladen front/rear	kg	350 / 110	430 / 172
Wheels/suspension system	3.1	Tyres		TPU/PU	Polyurethane (PU)
	3.2	Tyre size, front		Ø210x70	
	3.3	Tyre size, rear		Ø80x70	Ø80x98
	3.4	Additional wheels		Ø100x50	Ø80x48
	3.5	Wheels, number front/back (x=driven)		1x+1/4	1x+1/2
	3.6	Tread width, front	b10 mm	550	
	3.7	Tread width, rear	b11 mm	390	1002
Basic dimensions	4.2	Retracted mast height (h1)	h1 mm	1935	
	4.3	Free lift (h2)	h2 mm	100	
	4.4	Lift (h3)	h3 mm	1540	
	4.5	Extended mast height (h4)	h4 mm	1975	2125
	4.9	Height of tiller handle in drive position min./max.	h14 mm	800 / 1240	
	4.15	Height, lowered	h13 mm	85	
	4.19	total length	l1 mm	1615	1664
	4.20	Length including fork shank	l2 mm	465	514
	4.21.1	total width	b1 mm	800	
	4.22	Fork dimensions	s/e/l mm	55 x 172 x 1150	40 x 100 x 1150
	4.25	Width across forks	b5 mm	540	316
	4.26	Width between support arms/loading areas	b4 mm	-	882
	4.32	Ground clearance centre of wheelbase	m2 mm	30	35
	4.34.1	Aisle width (pallet 1000x1200 sideways)	Ast mm	2127	2163
	4.34.2	Aisle width (pallet 800x1200 length)	Ast mm	2059	2100
4.35	Turning radius	Wa mm	1295	1325	
Performance data	5.1	Travel speed laden/unladen	km/h	5 / 5	
	5.2	Lift speed laden/unladen	m/s	0.12 / 0.22	
	5.3	Lowering speed laden/unladen	m/s	0.15 / 0.13	
	5.8	Max. gradeability laden/unladen	%	6 / 16	
	5.10	Service brake		electric	
E-motor/Electronics	6.1	Drive motor, performance S2 60 min	kW	1	
	6.2	Lift motor, performance with S3	kW	2.2	
	6.3	Battery according to DIN 43531/35/36		no	
	6.4	Battery voltage/nominal capacity	V / Ah	24 / 50	
	6.5	Battery weight	kg	15	
	6.6.1	Energy consumption according to EN cycle	kWh/h	0.47	
	6.6.2	CO2 equivalent as per EN 16796	kg/h	0.3	

Other	8.1	Type of drive control		BLDC brushless direct current
	10.7	Schalldruckpegel nach EN12053	dB (A)	63

- This data sheet according to VDI guideline 2198 only states the technical values of the standard truck. Different tyres, other masts, additional equipment etc. may result in different values.

The German production facilities in
Norderstedt, Moosburg and Landsberg
are certified as well as our Genuine Parts
Center in Kaltenkirchen. ISO 9001
ISO 14001

Jungheinrich fork lift trucks meet
European safety requirements. 

**JUNGHEINRICH**