

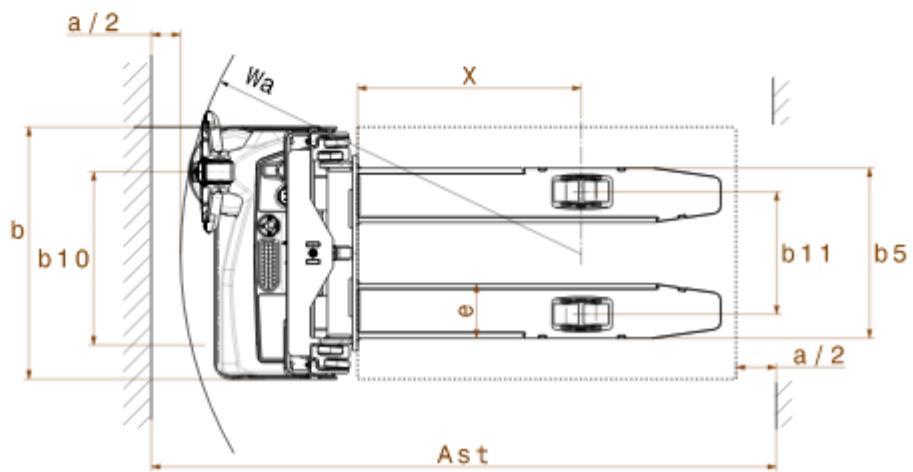

Electric pedestrian stacker **EJC BA 110 / 113 ZT**

Load capacity: 1000-1300 kg

EJC BA 110 / 113 ZT

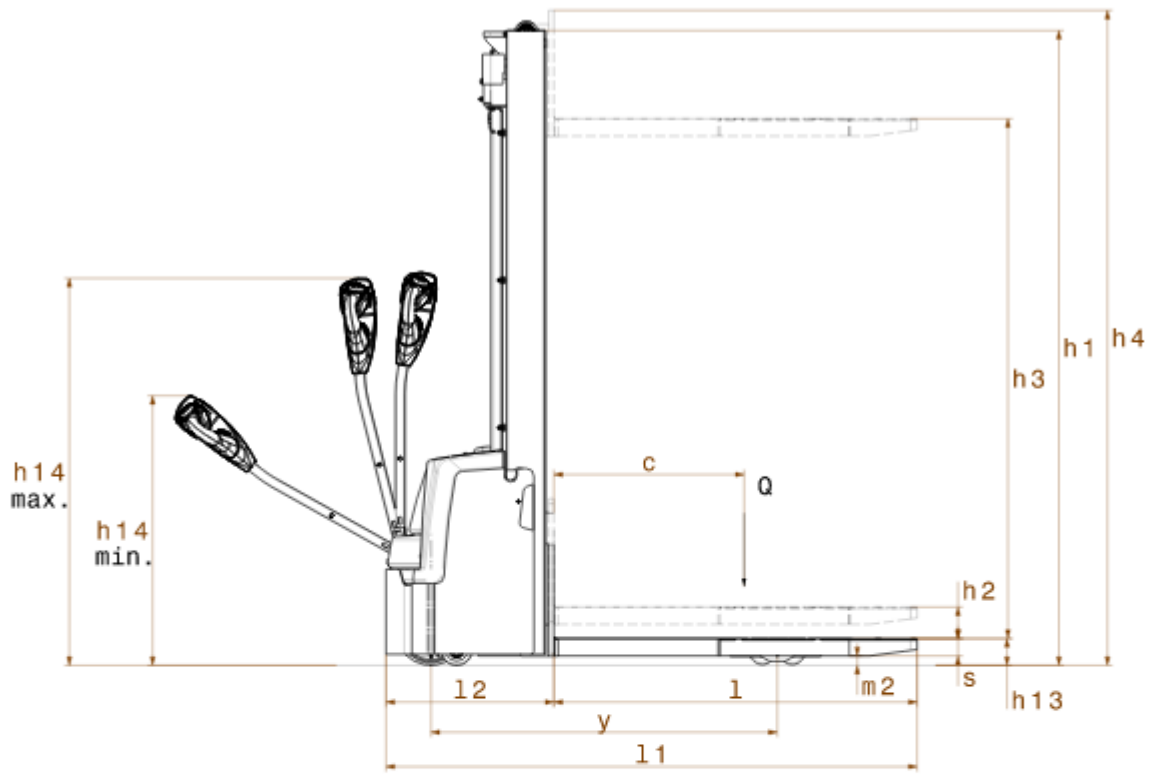

EJC BA 110 / 113 ZT

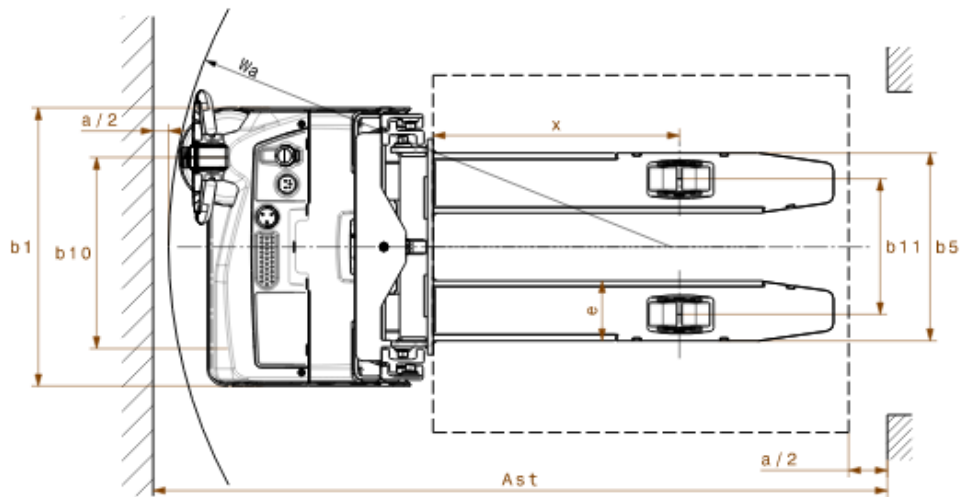
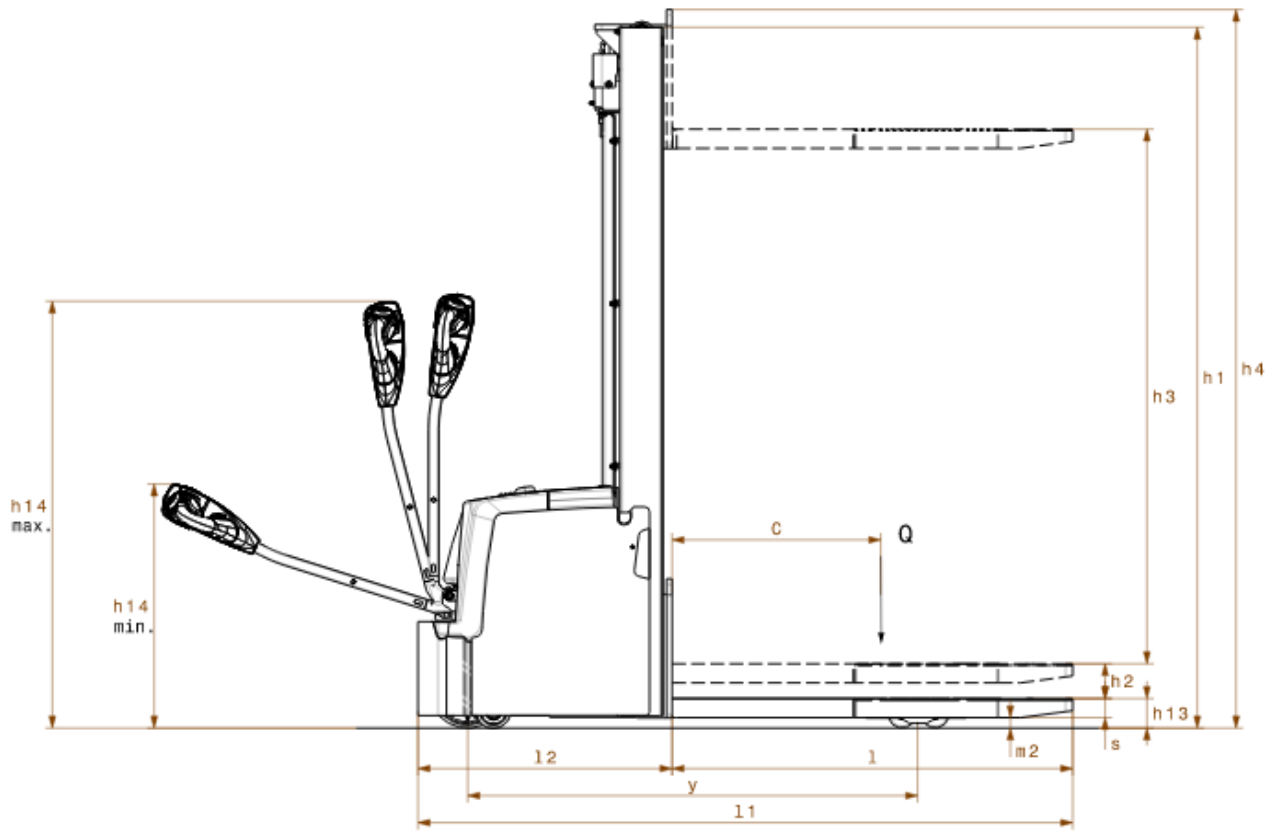

EJC BA 110 / 113 ZT

EJC BA 110 ZT, EJC BA 113 ZT	Lift (h3)	Retracted mast height (h1)	Free lift (h2)	Extended mast height (h4)
Duplex mast ZT	2300 mm	1615 mm	100 mm	2730 mm
	2500 mm	1715 mm	100 mm	2930 mm
	2900 mm	1915 mm	100 mm	3330 mm
	3300 mm	2115 mm	100 mm	3730 mm

VDI table

Stand-on: 12/2024

		Jungheinrich			
		EJC BA 110 ZT		EJC BA 113 ZT	
Characteristic	1.1	Manufacturer (abbreviated description)			
	1.2	Manufacturer's type designation			
	1.3	Drive	Electric		
	1.4	Operation	Pedestrian		
	1.5	Load capacity/load	Q kg	1000	1300
	1.6	Load centre distance	c mm	600	
	1.8	Load distance, centre of drive axle to fork	x mm	710	
	1.9	Wheelbase	y mm	1098	1296
	Weights	2.1.1	Service weight (incl. battery)	kg	551
2.2		Axle load laden front/rear	kg	468 / 1083	560 / 1435
2.3		Axle load unladen front/rear	kg	405 / 146	465 / 230
Wheels/suspension system	3.1	Tyres	TPU/PU		
	3.2	Tyre size, front	Ø210x70		
	3.3	Tyre size, rear	Ø80x70		
	3.4	Additional wheels	Ø100x50		
	3.5	Wheels, number front/back (x=driven)	1x+1/4		
	3.6	Tread width, front	b10 mm	550	
	3.7	Tread width, rear	b11 mm	390	
Basic dimensions	4.2	Retracted mast height (h1)	h1 mm	1615	
	4.3	Free lift (h2)	h2 mm	100	
	4.4	Lift (h3)	h3 mm	2300	
	4.5	Extended mast height (h4)	h4 mm	2730	
	4.9	Height of tiller handle in drive position min./max.	h14 mm	800 / 1240	
	4.15	Height, lowered	h13 mm	85	
	4.19	total length	l1 mm	1685	1880
	4.20	Length including fork shank	l2 mm	535	728
	4.21.1	total width	b1 mm	800	
	4.22	Fork dimensions	s/e/l mm	55 x 172 x 1150	
	4.25	Width across forks	b5 mm	540	
	4.32	Ground clearance centre of wheelbase	m2 mm	30	
	4.34.1	Aisle width (pallet 1000x1200 sideways)	Ast mm	2136	2330
	4.34.2	Aisle width (pallet 800x1200 length)	Ast mm	2103	2297
	4.35	Turning radius	Wa mm	1270	1464
Performance data	5.1	Travel speed laden/unladen	km/h	5 / 5	
	5.2	Lift speed laden/unladen	m/s	0.12 / 0.22	
	5.3	Lowering speed laden/unladen	m/s	0.15 / 0.13	
	5.8	Max. gradeability laden/unladen	%	6 / 16	
	5.10	Service brake		electric	
E-motor/Electronics	6.1	Drive motor, performance S2 60 min	kW	1	
	6.2	Lift motor, performance with S3	kW	2.2	
	6.3	Battery according to DIN 43531/35/36		no	
	6.4	Battery voltage/nominal capacity	V / Ah	24 / 50	24 / 100
	6.5	Battery weight	kg	15	30
	6.6.1	Energy consumption according to EN cycle	kWh/h	0.47	0.57
	6.6.2	CO2 equivalent as per EN 16796	kg/h	0.3	

Other	8.1	Type of drive control		BLDC brushless direct current
	10.7	Schalldruckpegel nach EN12053	dB (A)	63

- This data sheet according to VDI guideline 2198 only states the technical values of the standard truck. Different tyres, other masts, additional equipment etc. may result in different values.

The German production facilities in
Norderstedt, Moosburg and Landsberg
are certified as well as our Genuine Parts
Center in Kaltenkirchen. ISO 9001
ISO 14001

Jungheinrich fork lift trucks meet
European safety requirements. 

 **JUNGHEINRICH**