

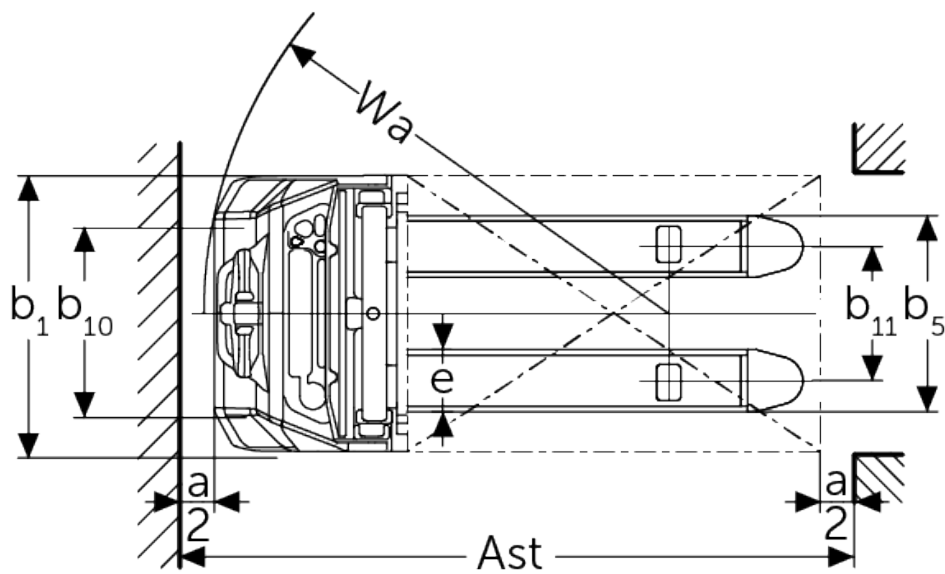

Electric pedestrian stacker **AMC 12z**

Lift height: 2814-3514 mm / Load capacity: 1200 kg

AMC 12z



VDI table

Stand-on: 12/2024

Characteristic	1.1	Manufacturer (abbreviated description)			Jungheinrich	
	1.2	Manufacturer's type designation			AMC 12z	
	1.3	Drive			Electric	
	1.4	Operation			Pedestrian	
	1.5	Load capacity/load	Q	kg	1200	
	1.5.1	Rated capacity/load with mast lift	Q	kg	1200	
	1.5.2	Rated capacity/load with support arm lift	Q	kg	1200	
	1.6	Load centre distance	c	mm	600	
	1.8	Load distance, centre of drive axle to fork	x	mm	752	
	1.9	Wheelbase	y	mm	1181	
Weights	2.1.1	Service weight (incl. battery)		kg	640	670
	2.2	Axle load laden front/rear		kg	670 / 1200	
	2.3	Axle load unladen front/rear		kg	485 / 185	
Wheels/ suspension system	3.4	Additional wheels			100x50	
	3.6	Tread width, front	b10	mm	550	
Basic dimensions	4.2	Retracted mast height (h1)	h1	mm	1970	2320
	4.4	Lift (h3)	h3	mm	2814	3514
	4.5	Extended mast height (h4)	h4	mm	3377	4077
	4.6	Initial lift	h5	mm	120	
	4.9	Height of tiller handle in drive position min./max.	h14	mm	710 / 1150	
	4.15	Height, lowered	h13	mm	86	
	4.19	total length	l1	mm	1752	
	4.20	Length including fork shank	l2	mm	602	
	4.21.1	total width	b1	mm	800	
	4.22	Fork dimensions	s/e/l	mm	60 x 180 x 1150	
	4.25	Width across forks	b5	mm	570	
	4.32	Ground clearance centre of wheelbase	m2	mm	24	
	4.34.1	Aisle width (pallet 1000x1200 sideways)	Ast	mm	2234	
	4.34.2	Aisle width (pallet 800x1200 length)	Ast	mm	2185	
	4.35	Turning radius	Wa	mm	1384	
Performance data	5.1	Travel speed laden/unladen		km/h	4.2 / 4.5	
	5.2	Lift speed laden/unladen		m/s	0.11 / 0.16	
	5.3	Lowering speed laden/unladen		m/s	0.13 / 0.11	
	5.7	Gradeability laden/unladen		%	5 / 10	
	5.10	Service brake			electromagnetic	
E-motor/Electronics	6.1	Drive motor, performance S2 60 min		kW	0.65	
	6.2	Lift motor, performance with S3		kW	2.2	
	6.3	Battery according to DIN 43531/35/36			no	
	6.4	Battery voltage/nominal capacity		V / Ah	24 / 60	
	6.5	Battery weight		kg	19	
	6.6	Energy consumption according to VDI cycle		kWh/h	0.66	

Other	8.1	Type of drive control		Impulse/DC
	10.7	Schalldruckpegel nach EN12053	dB (A)	70

- This data sheet according to VDI guideline 2198 only states the technical values of the standard truck. Different tyres, other masts, additional equipment etc. may result in different values.

The German production facilities in
Norderstedt, Moosburg and Landsberg
are certified as well as our Genuine Parts
Center in Kaltenkirchen. ISO 9001
ISO 14001

Jungheinrich fork lift trucks meet
European safety requirements. 

**JUNGHEINRICH**