



# Electric three-wheel counterbalance forklift truck

## **EFG BB 216k**

Lift height: 3000-6500 mm / Load capacity: 1600 kg

# EFG BB 216k

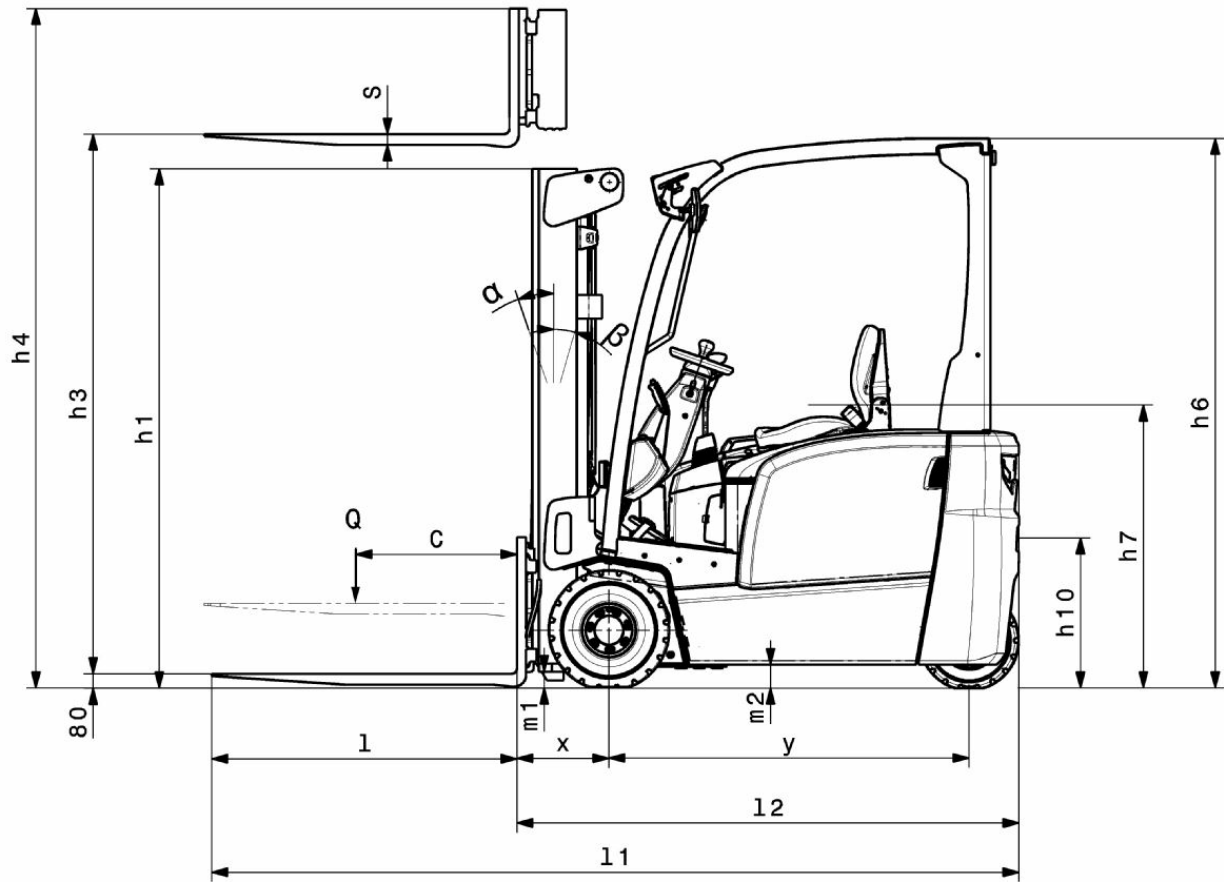

# EFG BB 216k

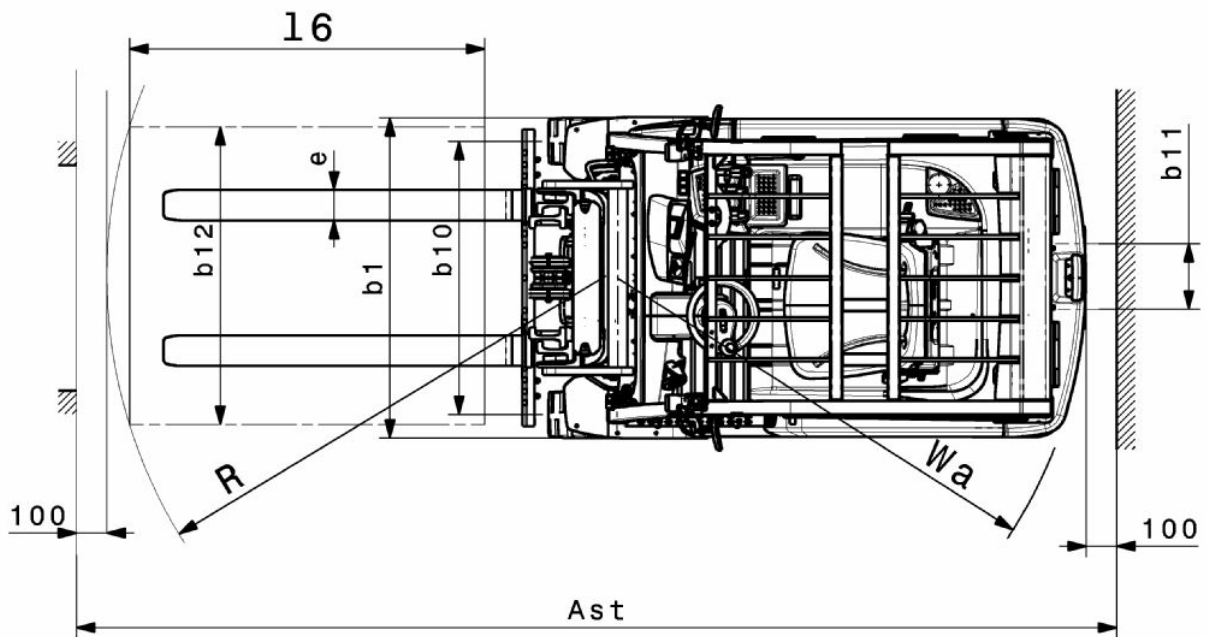

# EFG BB 216k

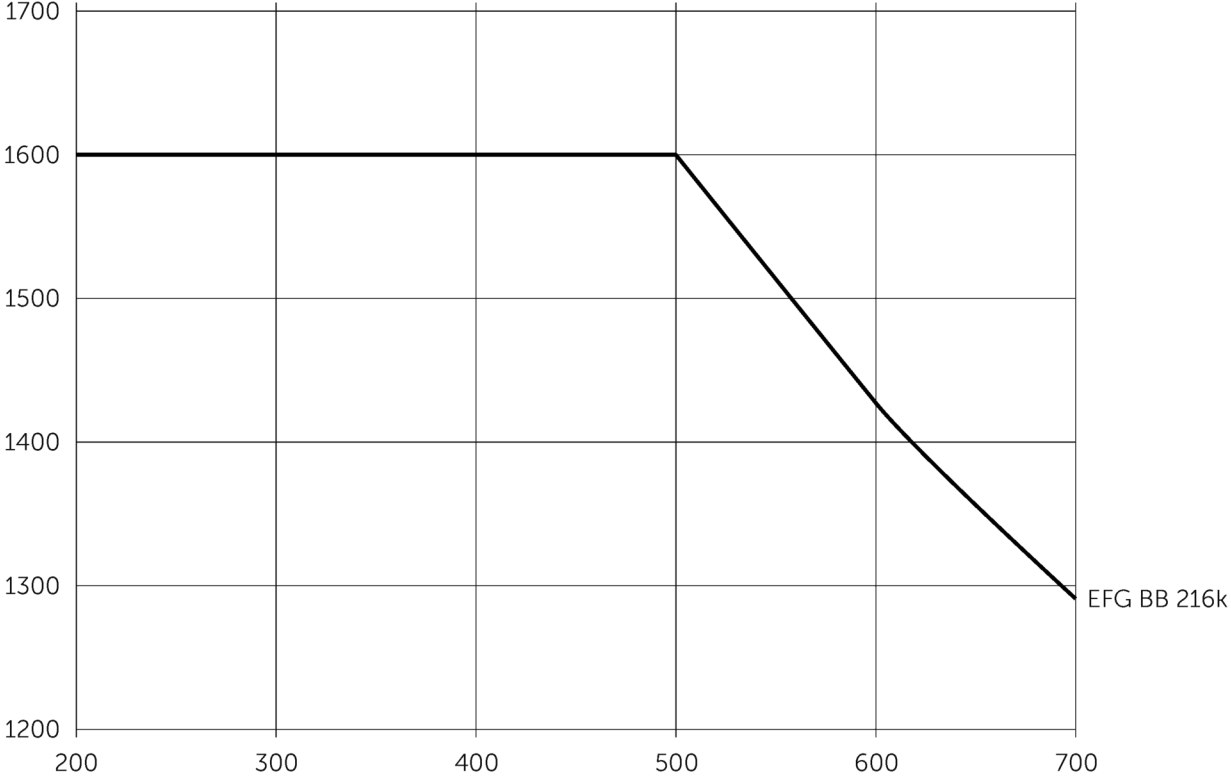

# EFG BB 216k

EFG BB 216k	Lift (h3)	Retracted mast height (h1)	Free lift (h2)	Extended mast height (h4)	Forward/backward tilt of mast
Duplex mast ZT	<b>3000 mm</b>	<b>2000 mm</b>	<b>150 mm</b>	<b>3555 mm</b>	<b>7 / 5 °</b>
	3300 mm	2150 mm	150 mm	3855 mm	7 / 5 °
	3600 mm	2300 mm	150 mm	4155 mm	7 / 5 °
	4000 mm	2500 mm	150 mm	4555 mm	7 / 5 °
	4500 mm	2800 mm	150 mm	5055 mm	7 / 5 °
	5000 mm	3050 mm	150 mm	5555 mm	7 / 5 °
Duplex mast ZZ	<b>3300 mm</b>	<b>2105 mm</b>	<b>1470 mm</b>	<b>3855 mm</b>	<b>7 / 5 °</b>
	3600 mm	2255 mm	1620 mm	4155 mm	7 / 5 °
	4000 mm	2455 mm	1820 mm	4555 mm	7 / 5 °
Triplex mast DZ	<b>4500 mm</b>	<b>2005 mm</b>	<b>1360 mm</b>	<b>5055 mm</b>	<b>7 / 5 °</b>
	4800 mm	2105 mm	1460 mm	5355 mm	7 / 5 °
	5000 mm	2180 mm	1530 mm	5555 mm	7 / 5 °
	5500 mm	2355 mm	1710 mm	6055 mm	7 / 5 °
	6000 mm	2555 mm	1910 mm	6555 mm	7 / 5 °
	6500 mm	2805 mm	2160 mm	7055 mm	7 / 5 °

# VDI table

Stand-on: 12/2024

Characteristic	1.1	Manufacturer (abbreviated description)		Jungheinrich	
	1.2	Manufacturer's type designation		<b>EFG BB</b>	
	1.3	Drive		Electric	
	1.4	Operation		Seat	
	1.5	Load capacity/load	Q	kg	1600
	1.6	Load centre distance	c	mm	500
	1.8	Load distance, centre of drive axle to fork	x	mm	352
	1.9	Wheelbase	y	mm	1357
	Weights	2.1.1	Service weight (incl. battery)		kg
2.2		Axle load laden front/rear		kg	4102 / 544
2.3		Axle load unladen front/rear		kg	1473 / 1571
Wheels/suspension system	3.1	Tyres			Super-elastic (SE)
	3.2	Tyre size, front			18 x 7 - 8
	3.3	Tyre size, rear			140 / 55 - 9
	3.5	Wheels, number front/back (x=driven)			2x / 2
	3.6	Tread width, front	b10	mm	904
	3.7	Tread width, rear	b11	mm	211
	Basic dimensions	4.1	Forward/backward tilt of mast	a/β	°
4.2		Retracted mast height (h1)	h1	mm	2000
4.2.1		total height	h15	mm	2080
4.3		Free lift (h2)	h2	mm	150
4.4		Lift (h3)	h3	mm	3000
4.5		Extended mast height (h4)	h4	mm	3555
4.7		Height of overhead guard (cab)	h6	mm	2080
4.8		Seat height/stand height	h7	mm	1030
4.12		Coupling height	h10	mm	560
4.12.1		2. Coupling height		mm	0
4.19		total length	l1	mm	2899
4.20		Length including fork shank	l2	mm	1899
4.21.1		total width	b1	mm	1060
4.22		Fork dimensions	s/e/l	mm	40 x 100 x 1000
4.23		Fork carriage connection class			2A
4.24		Fork carriage width	b3	mm	980
4.31		Ground clearance laden under mast	m1	mm	97
4.32		Ground clearance centre of wheelbase	m2	mm	88
4.34.1		Aisle width (pallet 1000x1200 sideways)	Ast	mm	3224
4.34.2		Aisle width (pallet 800x1200 length)	Ast	mm	3348
4.35		Turning radius	Wa	mm	1545
4.36		Smallest pivot point distance	b13	mm	0
Performance data		5.1	Travel speed laden/unladen		km/h
	5.2	Lift speed laden/unladen		m/s	0.43 / 0.53
	5.3	Lowering speed laden/unladen		m/s	0.51 / 0.55
	5.5	Drawbar pull laden		N	1300
	5.6	Max. drawbar pull laden/unladen		N	9000 / 9400
	5.7	Gradeability laden/unladen		%	6.5 / 14
	5.8	Max. gradeability laden/unladen		%	13.5 / 16
	5.9	Acceleration time laden/unladen		s	5.5 / 5

	5.10	Service brake		mechanical/hydraulic
E-motor/Electronics	6.1	Drive motor, performance S2 60 min	kW	3.7
	6.1.1	2. Drive motor, performance S2 60 min	kW	3.7
	6.2	Lift motor, performance with S3	kW	10
	6.3	Battery according to DIN 43531/35/36		DIN 43531 A
	6.4	Battery voltage/nominal capacity	V / Ah	48 / 500
	6.5	Battery weight	kg	708
	6.6.1	Energy consumption according to EN cycle	kWh/h	4.25
	6.6.2	CO2 equivalent as per EN 16796	kg/h	2.3
	6.7	Throughput	t/h	113
	6.8.1	Energy consumption with max. throughput	kWh/h	5.13
Other	8.1	Type of drive control		Impulse/AC
	10.1	Operating pressure for attachment	bar	230
	10.2	Oil flow for attachments	l/min	24
	10.7	Schalldruckpegel nach EN12053	dB (A)	75
	10.8	Trailer coupling, model/type DIN		Bolts
<p>- This data sheet according to VDI guideline 2198 only states the technical values of the standard truck. Different tyres, other masts, additional equipment etc. may result in different values.</p>				

The German production facilities in  
Norderstedt, Moosburg and Landsberg  
are certified as well as our Genuine Parts  
Center in Kaltenkirchen. ISO 9001  
ISO 14001

Jungheinrich fork lift trucks meet  
European safety requirements. 

 **JUNGHEINRICH**