



Electric four wheel counterbalance forklift truck

EFG BC 316-330

Lift height: 3000-6500 mm / Load capacity: 1600-3000 kg

EFG BC 316-330

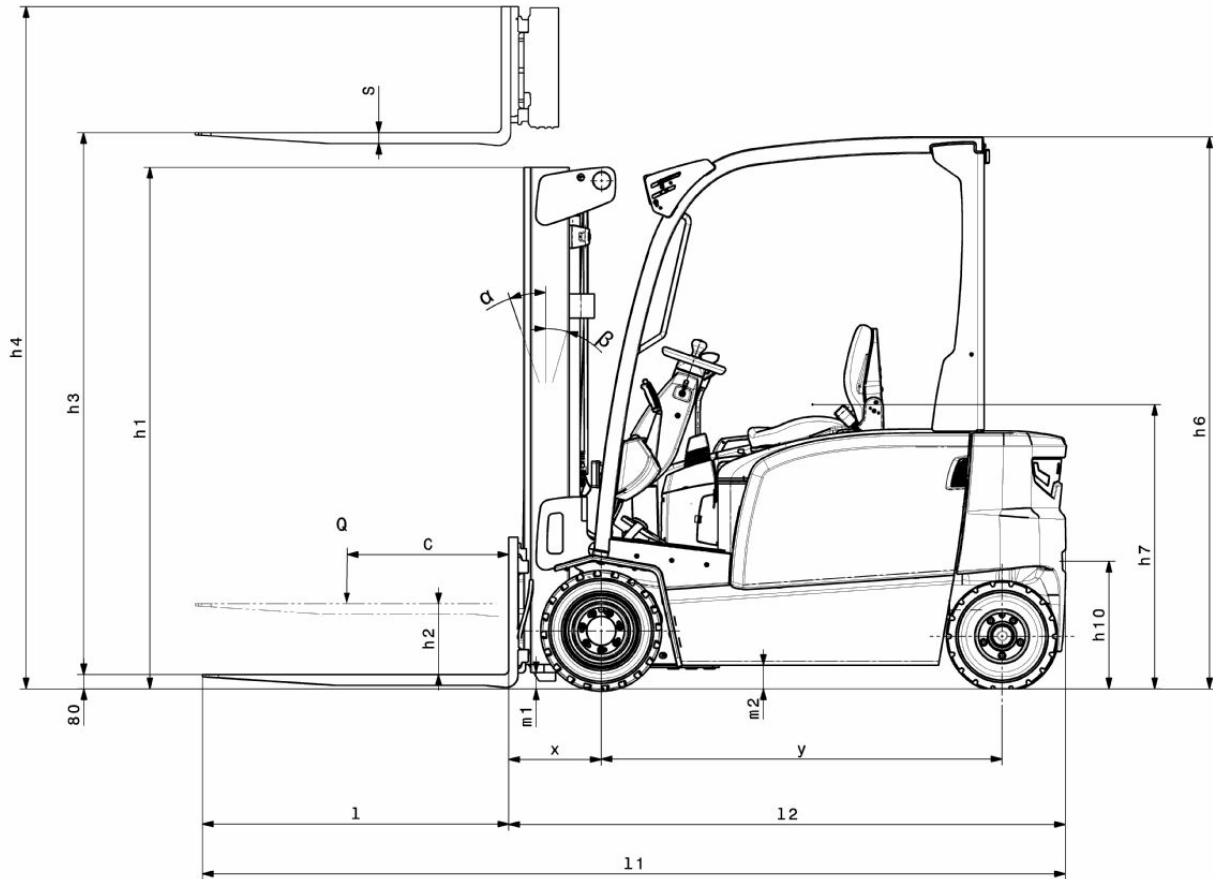

EFG BC 316-330

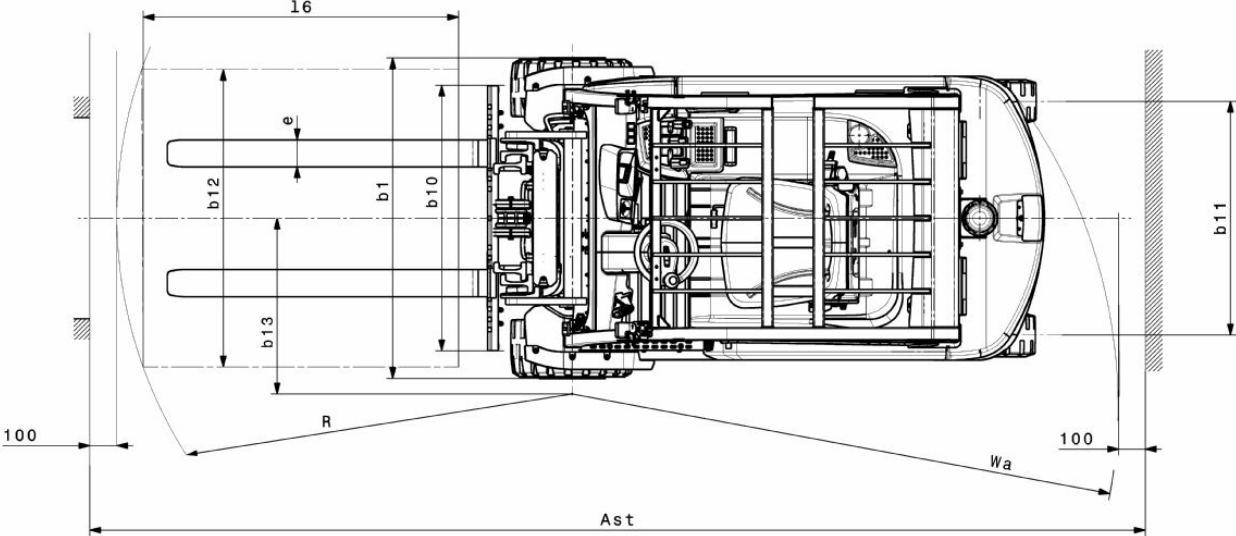

EFG BC 316-330

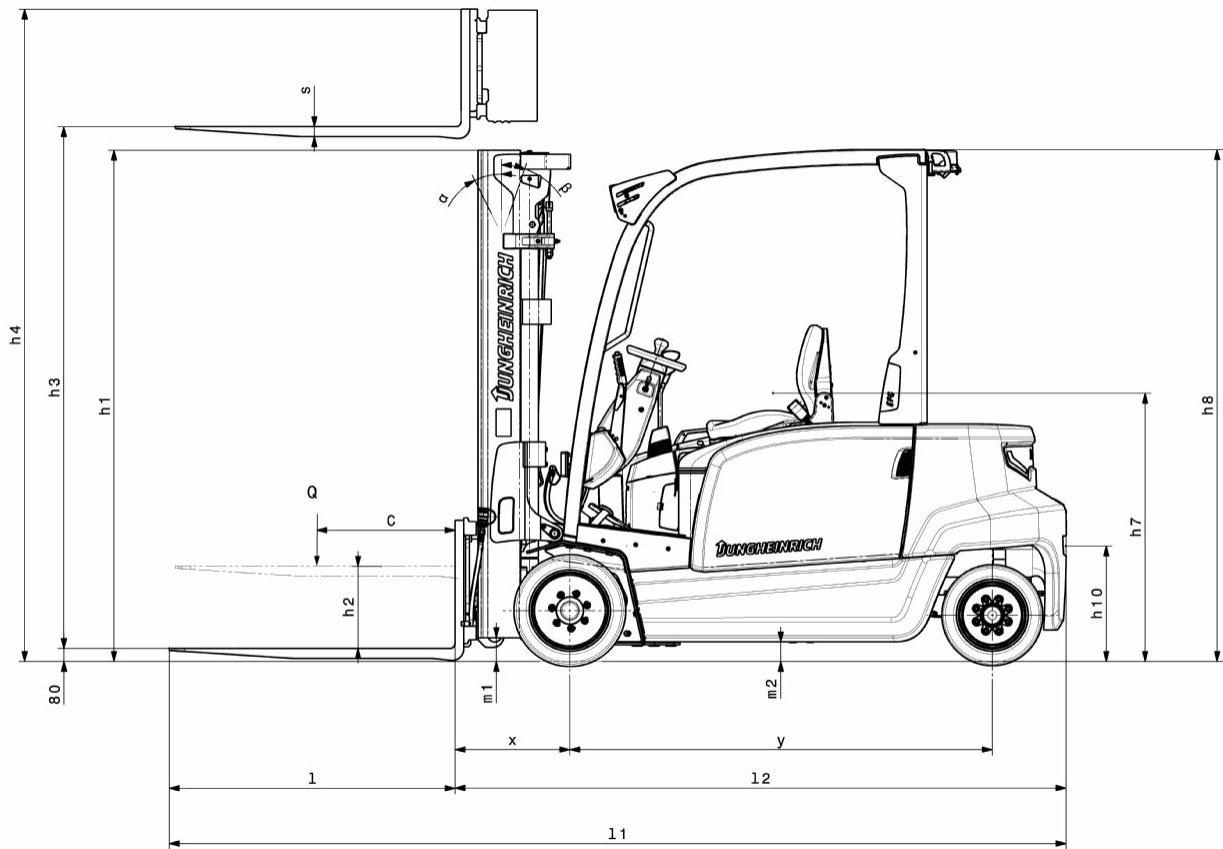

EFG BC 316-330

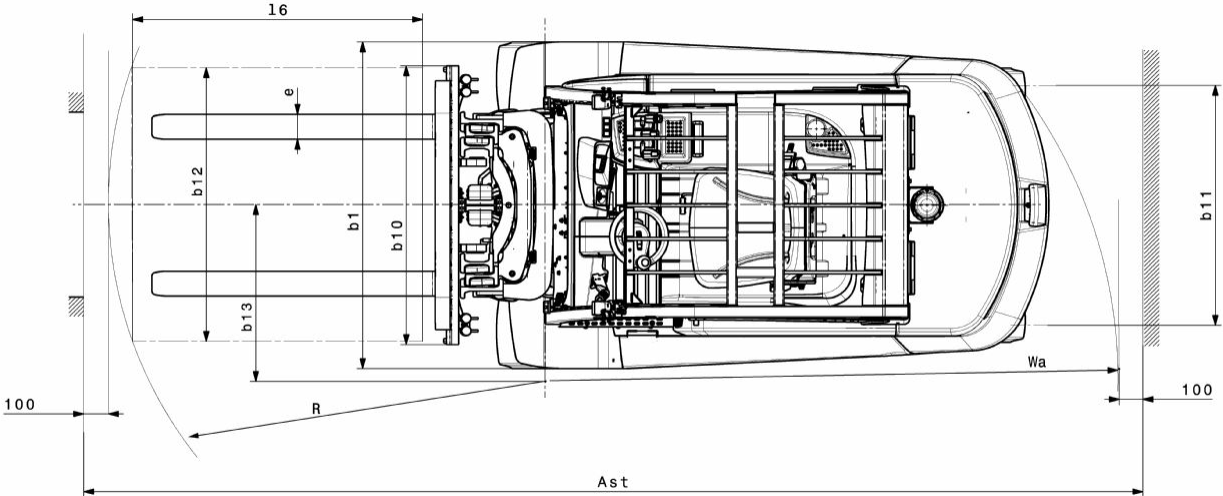

EFG BC 316-330

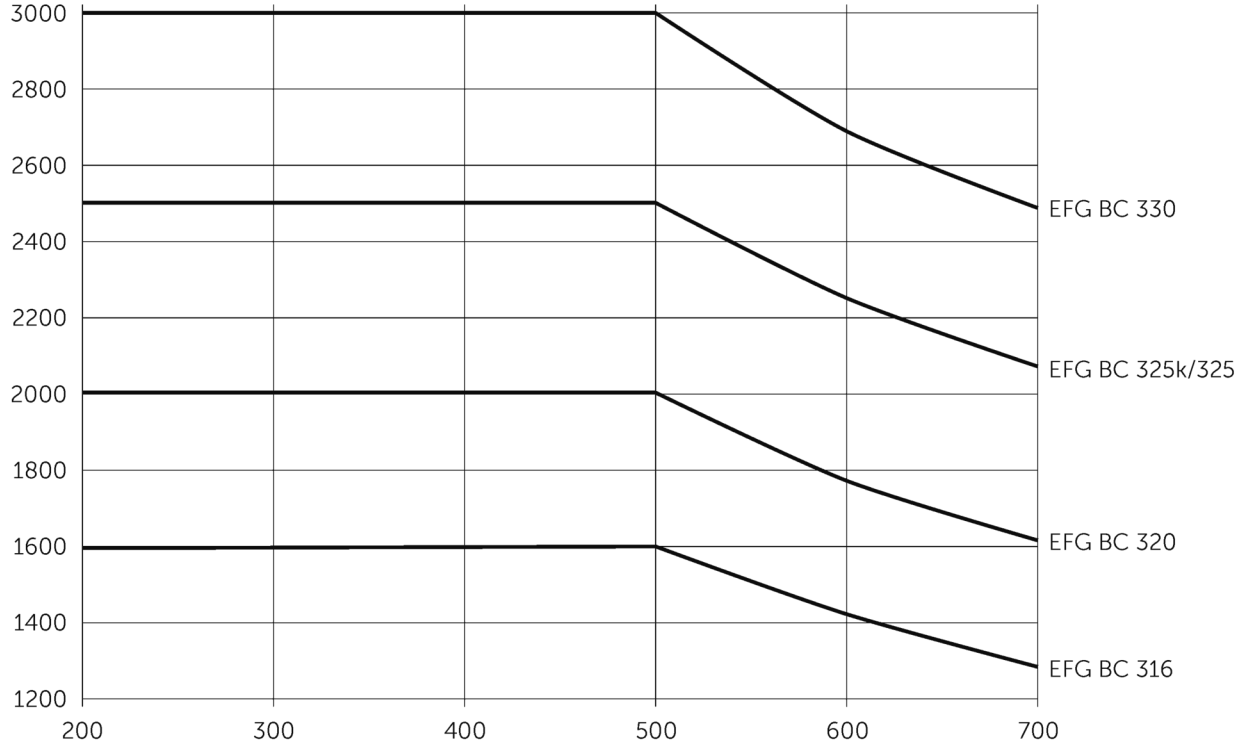

EFG BC 316-330

EFG BC 316	Lift (h3)	Retracted mast height (h1)	Free lift (h2)	Extended mast height (h4)	Forward/backward tilt of mast
Duplex mast ZT	3000 mm	2000 mm	150 mm	3555 mm	7 / 5 °
	3300 mm	2150 mm	150 mm	3855 mm	7 / 5 °
	3600 mm	2300 mm	150 mm	4155 mm	7 / 5 °
	4000 mm	2500 mm	150 mm	4555 mm	7 / 5 °
	4500 mm	2800 mm	150 mm	5055 mm	7 / 5 °
	5000 mm	3050 mm	150 mm	5555 mm	7 / 5 °
Duplex mast ZZ	3300 mm	2105 mm	1470 mm	3855 mm	7 / 5 °
	3600 mm	2255 mm	1620 mm	4155 mm	7 / 5 °
	4000 mm	2455 mm	1820 mm	4555 mm	7 / 5 °
Triplex mast DZ	4500 mm	2005 mm	1360 mm	5055 mm	7 / 5 °
	4800 mm	2105 mm	1460 mm	5355 mm	7 / 5 °
	5000 mm	2180 mm	1530 mm	5555 mm	7 / 5 °
	5500 mm	2355 mm	1710 mm	6055 mm	7 / 5 °
	6000 mm	2555 mm	1910 mm	6555 mm	7 / 5 °
	6500 mm	2805 mm	2160 mm	7055 mm	7 / 5 °
EFG BC 320	Lift (h3)	Retracted mast height (h1)	Free lift (h2)	Extended mast height (h4)	Forward/backward tilt of mast
Duplex mast ZT	3000 mm	2000 mm	150 mm	3605 mm	7 / 5 °
	3300 mm	2150 mm	150 mm	3905 mm	7 / 5 °
	3600 mm	2300 mm	150 mm	4205 mm	7 / 5 °
	4000 mm	2500 mm	150 mm	4605 mm	7 / 5 °
	4500 mm	2800 mm	150 mm	5105 mm	7 / 5 °
	5000 mm	3050 mm	150 mm	5605 mm	7 / 5 °
Duplex mast ZZ	3300 mm	2105 mm	1470 mm	3935 mm	7 / 5 °
	3600 mm	2255 mm	1620 mm	4235 mm	7 / 5 °
	4000 mm	2455 mm	1820 mm	4635 mm	7 / 5 °
Triplex mast DZ	4500 mm	2005 mm	1360 mm	5135 mm	7 / 5 °
	4800 mm	2105 mm	1460 mm	5435 mm	7 / 5 °
	5000 mm	2180 mm	1530 mm	5635 mm	7 / 5 °
	5500 mm	2355 mm	1710 mm	6135 mm	7 / 5 °
	6000 mm	2555 mm	1910 mm	6635 mm	7 / 5 °
	6500 mm	2805 mm	2160 mm	7135 mm	7 / 5 °
EFG BC 325k, EFG BC 325	Lift (h3)	Retracted mast height (h1)	Free lift (h2)	Extended mast height (h4)	Forward/backward tilt of mast
Duplex mast ZT	3100 mm	2200 mm	150 mm	3700 mm	7 / 5 °
	3300 mm	2300 mm	150 mm	3900 mm	7 / 5 °
	3500 mm	2400 mm	150 mm	4100 mm	7 / 5 °
	3700 mm	2500 mm	150 mm	4300 mm	7 / 5 °
	4000 mm	2650 mm	150 mm	4600 mm	7 / 5 °
	4500 mm	2950 mm	150 mm	5100 mm	7 / 5 °
Duplex mast ZZ	3100 mm	2160 mm	1600 mm	3700 mm	7 / 5 °
	3300 mm	2260 mm	1700 mm	3900 mm	7 / 5 °
	3500 mm	2360 mm	1800 mm	4100 mm	7 / 5 °
	4000 mm	2610 mm	2060 mm	4600 mm	7 / 5 °
Triplex mast DZ	4400 mm	2060 mm	1500 mm	5000 mm	7 / 5 °
	4700 mm	2160 mm	1600 mm	5300 mm	7 / 5 °

	5000 mm	2260 mm	1700 mm	5600 mm	7 / 5 °
EFG BC 330	Lift (h3)	Retracted mast height (h1)	Free lift (h2)	Extended mast height (h4)	Forward/backward tilt of mast
Duplex mast ZT	3100 mm	2200 mm	150 mm	3850 mm	7 / 5 °
	3300 mm	2300 mm	150 mm	4050 mm	7 / 5 °
	3500 mm	2400 mm	150 mm	4250 mm	7 / 5 °
	3700 mm	2500 mm	150 mm	4450 mm	7 / 5 °
	4000 mm	2650 mm	150 mm	4750 mm	7 / 5 °
	4500 mm	2950 mm	150 mm	5250 mm	7 / 5 °
Duplex mast ZZ	3100 mm	2160 mm	1440 mm	3850 mm	7 / 5 °
	3300 mm	2260 mm	1540 mm	4050 mm	7 / 5 °
	3500 mm	2360 mm	1640 mm	4250 mm	7 / 5 °
	4000 mm	2610 mm	1900 mm	4750 mm	7 / 5 °
Triplex mast DZ	4400 mm	2060 mm	1340 mm	5150 mm	7 / 5 °
	4700 mm	2160 mm	1440 mm	5450 mm	7 / 5 °
	5000 mm	2260 mm	1540 mm	5750 mm	7 / 5 °

VDI table

Stand-on: 12/2024

Characteristic	1.1	Manufacturer (abbreviated description)		Jungheinrich				
	1.2	Manufacturer's type designation		EFG BC 316-330				
	1.3	Drive		Electric				
	1.4	Operation		Seat				
	1.5	Load capacity/load	Q kg	1600	2000	2500	3000	
	1.6	Load centre distance	c mm	500				
	1.8	Load distance, centre of drive axle to fork	x mm	352		467		472
	1.9	Wheelbase	y mm	1506		1453	1561	1700
	Weights	2.1.1	Service weight (incl. battery)	kg	3230	3317	4351	4454
2.2		Axle load laden front/rear	kg	4012 / 818	4738 / 579	6166 / 685	6259 / 695	6968 / 774
2.3		Axle load unladen front/rear	kg	1514 / 1716	1606 / 1711	1833 / 2518	1960 / 2494	2225 / 2517
Wheels/suspension system	3.1	Tyres		Super-elastic (SE)				
	3.2	Tyre size, front		18 x 7 - 8	200 / 50 - 10	18 x 9 - 12		TANDEM, 18 x 5 & 6 - 12(1/8)
	3.3	Tyre size, rear		16 x 6 - 8		16 x 6 -10 (1/2)		16 x 7 -10 (1/2)
	3.5	Wheels, number front/back (x=driven)		2x / 2				
	3.6	Tread width, front	b10 mm	904	924	938		1013
	3.7	Tread width, rear	b11 mm	870		864		995
	Basic dimensions	4.1	Forward/backward tilt of mast	a/β °	7 / 5			
4.2		Retracted mast height (h1)	h1 mm	2000		2200		
4.2.1		total height	h15 mm	2080		2200		
4.3		Free lift (h2)	h2 mm	150				
4.4		Lift (h3)	h3 mm	3000		3100		
4.5		Extended mast height (h4)	h4 mm	3555	3605	3700	3850	
4.7		Height of overhead guard (cab)	h6 mm	2080				
4.8		Seat height/stand height	h7 mm	1030				
4.12		Coupling height	h10 mm	475				
4.19		total length	l1 mm	3096		3213	3321	3469
4.20		Length including fork shank	l2 mm	2096		2213	2321	2469
4.21.1		total width	b1 mm	1060	1120	1170		1313
4.22		Fork dimensions	s/ e/l mm	40 x 100 x 1000				45 x 125 x 1000
4.23		Fork carriage connection class		2A				3A
4.24		Fork carriage width	b3 mm	980		1120		
4.31		Ground clearance laden under mast	m1 mm	97				
4.32		Ground clearance centre of wheelbase	m2 mm	88				
4.34.1		Aisle width (pallet 1000x1200 sideways)	Ast mm	3513		3648	3767	3942
4.34.2		Aisle width (pallet 800x1200 length)	Ast mm	3712		3847	3967	4142
4.35		Turning radius	Wa mm	1960		1980	2100	2270
4.36	Smallest pivot point distance	b13 mm	562		542	600	667	
Performance data	5.1	Travel speed laden/unladen	km/h	15 / 15		17 / 18		
	5.2	Lift speed laden/unladen	m/s	0.43 / 0.53	0.34 / 0.44	0.4 / 0.5		0.3 / 0.32
	5.3	Lowering speed laden/unladen	m/s	0.51 / 0.55				
	5.5	Drawbar pull laden	N	1300	1600	2400		2300
	5.6	Max. drawbar pull laden/unladen	N	9000 / 9400	9200 / 10500	14000 / 8700		13800 / 14600
	5.7	Gradeability laden/unladen	%	6.5 / 14	5 / 11	9 / 13		8 / 12

	5.8	Max. gradeability laden/unladen	%	13.5 / 16	11 / 15	16 / 22	15 / 22
	5.9	Acceleration time laden/unladen	s	5.5 / 5	6 / 5.2	5.6 / 5	5.7 / 5.2
	5.10	Service brake		mechanical/hydraulic			
E-motor/Electronics	6.1	Drive motor, performance S2 60 min	kW	3.7		4.6	
	6.1.1	2. Drive motor, performance S2 60 min	kW	3.7		4.6	
	6.2	Lift motor, performance with S3	kW	10		15.5	
	6.3	Battery according to DIN 43531/35/36		DIN 43531 A			
	6.4	Battery voltage/nominal capacity	V / Ah	48 / 625		48 / 750	
	6.5	Battery weight	kg	856		1013	
	6.6.1	Energy consumption according to EN cycle	kWh/h	4.25	4.8	5.77	6.88
	6.6.2	CO2 equivalent as per EN 16796	kg/h	2.3	2.6	3.1	3.7
	6.7	Throughput	t/h	113	136	172	196
	6.8.1	Energy consumption with max. throughput	kWh/h	5.13	5.88	8.84	7.71
Other	8.1	Type of drive control		Impulse/AC			
	10.1	Operating pressure for attachment	bar	230			
	10.2	Oil flow for attachments	l/min	24		41	
	10.7	Schalldruckpegel nach EN12053	dB (A)	74		78	
	10.8	Trailer coupling, model/type DIN		Bolts			
- This data sheet according to VDI guideline 2198 only states the technical values of the standard truck. Different tyres, other masts, additional equipment etc. may result in different values.							

The German production facilities in
Norderstedt, Moosburg and Landsberg
are certified as well as our Genuine Parts
Center in Kaltenkirchen. ISO 9001
ISO 14001

Jungheinrich fork lift trucks meet
European safety requirements. 

**JUNGHEINRICH**