

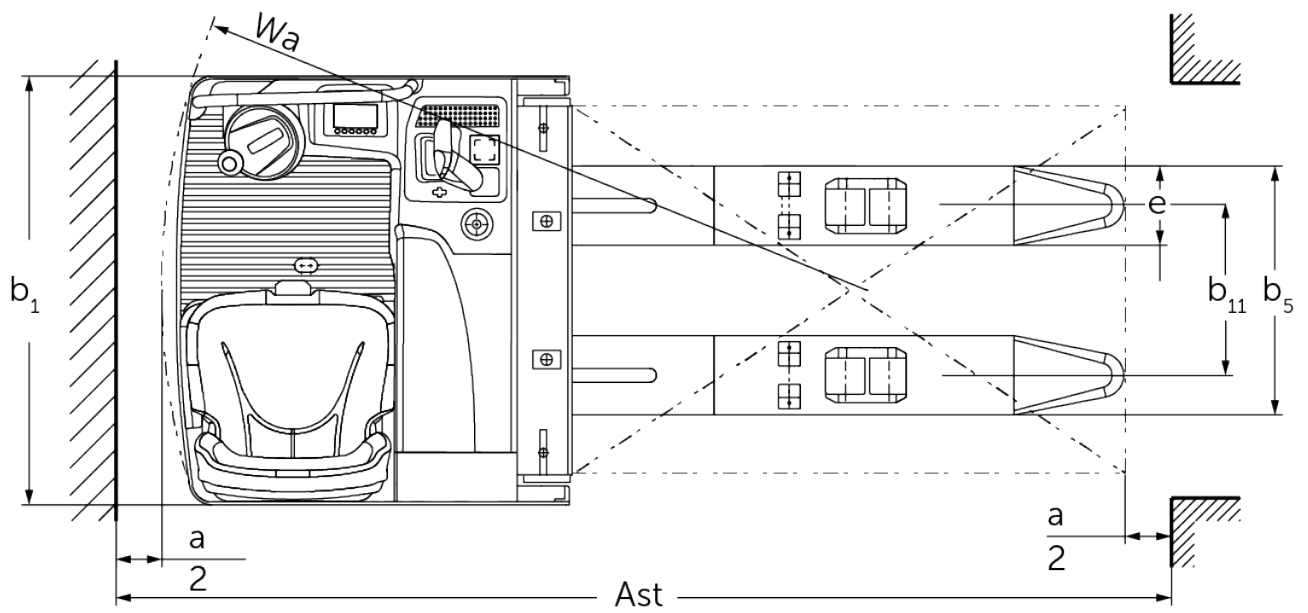

Electric sideways-seated pallet truck **ESE 220-320**

Lift height: 125 mm / Load capacity: 2000 kg

ESE 220-320

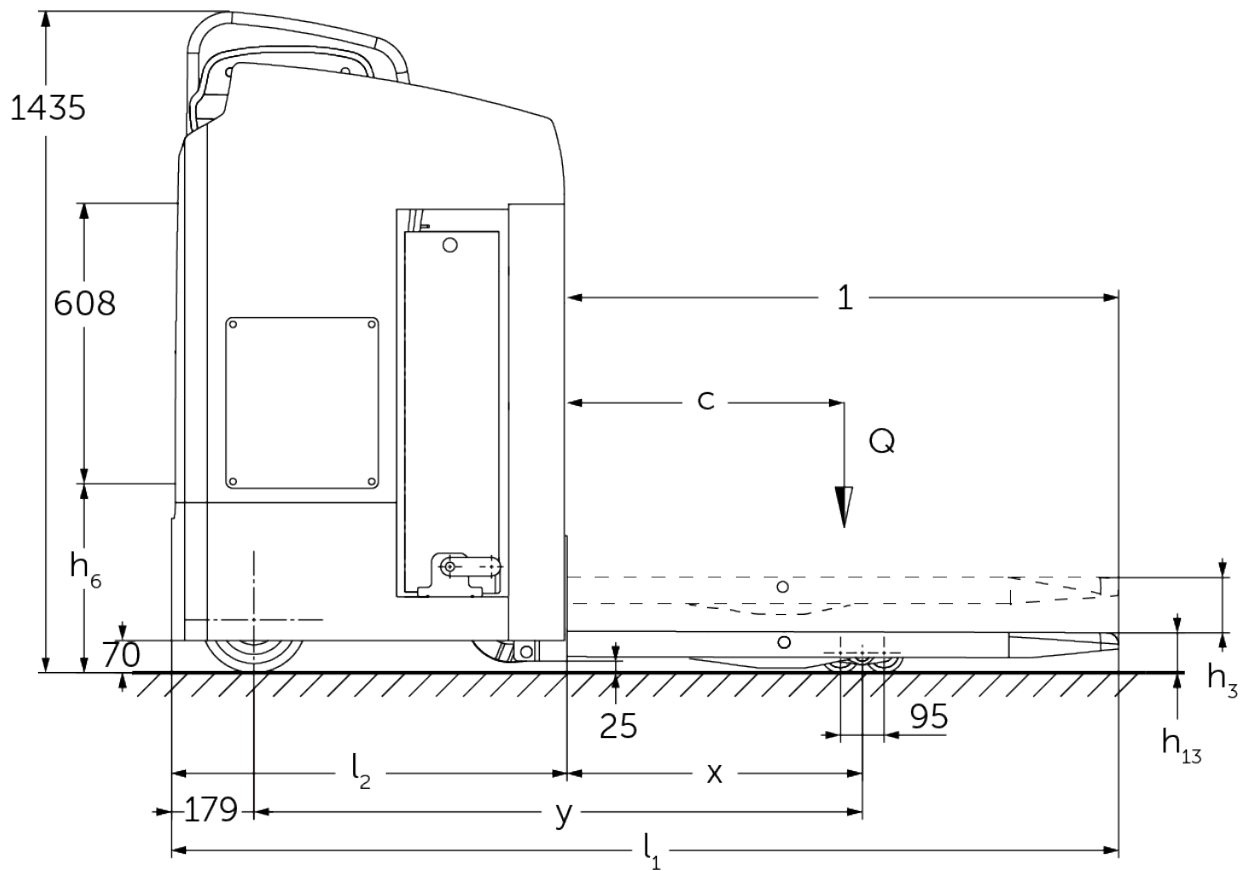

VDI table

Stand-on: 01/2025

Characteristic	1.1	Manufacturer (abbreviated description)		Jungheinrich	
	1.2	Manufacturer's type designation		ESE 220-320	
	1.3	Drive		Electric	
	1.4	Operation		Seat	
	1.5	Load capacity/load	Q kg	2000	
	1.6	Load centre distance	c mm	600	
	1.8	Load distance, centre of drive axle to fork	x mm	868	
	1.9	Wheelbase	y mm	1548	
	Weights	2.1.1	Service weight (incl. battery)	kg	1062
2.2		Axle load laden front/rear	kg	1896 / 1142	1902 / 1182
2.3		Axle load unladen front/rear	kg	258 / 808	264 / 816
Wheels/suspension system	3.1	Tyres		Polyurethane (PU)	
	3.2	Tyre size, front		Ø 230 x 78	
	3.3	Tyre size, rear		Ø 85x85	
	3.4	Additional wheels		Ø 140 x 54	
	3.5	Wheels, number front/back (x=driven)		2 + 1x / 4	
	3.6	Tread width, front	b10 mm	544	645
	3.7	Tread width, rear	b11 mm	385	
Basic dimensions	4.4	Lift (h3)	h3 mm	125	
	4.8	Seat height/stand height	h7 mm	1020	
	4.15	Height, lowered	h13 mm	90	
	4.19	total length	l1 mm	2009	
	4.20	Length including fork shank	l2 mm	859	
	4.21.1	total width	b1 mm	820	930
	4.22	Fork dimensions	s/e/l mm	60 x 172 x 1150	
	4.25	Width across forks	b5 mm	540	
	4.32	Ground clearance centre of wheelbase	m2 mm	25	
	4.34.2	Aisle width (pallet 800x1200 length)	Ast mm	2259	
	4.35	Turning radius	Wa mm	1739	1751
Performance data	5.1	Travel speed laden/unladen	km/h	10 / 12.5	
	5.2	Lift speed laden/unladen	m/s	0.06 / 0.07	
	5.3	Lowering speed laden/unladen	m/s	0.06 / 0.05	
	5.8	Max. gradeability laden/unladen	%	8 / 13	
	5.10	Service brake		electric	
E-motor/Electronics	6.1	Drive motor, performance S2 60 min	kW	2.8	
	6.2	Lift motor, performance with S3	kW	2.2	
	6.3	Battery according to DIN 43531/35/36		no	
	6.4	Battery voltage/nominal capacity	V / Ah	24 / 465	
	6.5	Battery weight	kg	380	
	6.6	Energy consumption according to VDI cycle	kWh/h	0	
	6.6.1	Energy consumption according to EN cycle	kWh/h	0.41	0.43
	6.6.2	CO2 equivalent as per EN 16796	kg/h	0.2	
Other	8.1	Type of drive control		AC	

- This data sheet according to VDI guideline 2198 only states the technical values of the standard truck. Different tyres, other masts, additional equipment etc. may result in different values.

The values in the table apply for the width across forks 540 mm, fork length 1,150 mm, raised support arm lift.

- VDI no. 1.8: lowered support arm lift: $x + 95$ mm.
- VDI no. 1.9: lowered support arm lift: $y + 95$ mm.
- VDI no. 4.35: lowered support arm lift: $W_a + 95$ mm.

The German production facilities in
Norderstedt, Moosburg and Landsberg
are certified as well as our Genuine Parts
Center in Kaltenkirchen. ISO 9001
ISO 14001

Jungheinrich fork lift trucks meet
European safety requirements. 

 **JUNGHEINRICH**