



Electric pedestrian pallet truck **AME 16**

Lift height: 115 mm / Load capacity: 1600 kg



AME 16

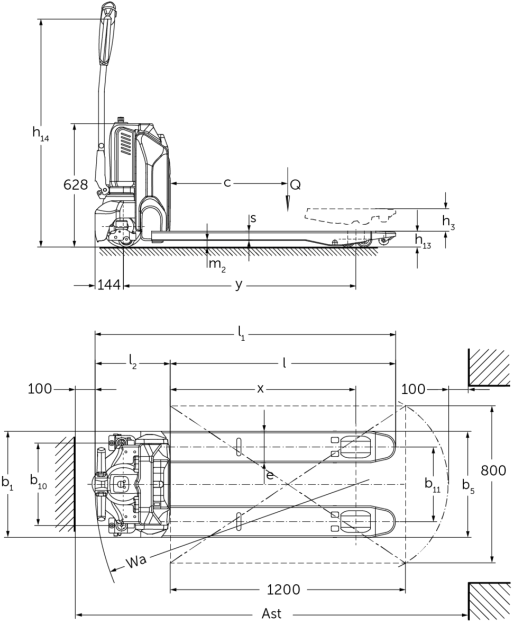

VDI table

Characteristic	1.1	Manufacturer (abbreviated description)		Jungheinrich		
	1.2	Manufacturer's type designation		AME 16 (540x1,000)	AME 16 (540x1,150)	AME 16 (685x1,150)
	1.3	Drive type		electric		
	1.4	Operation		Pedestrian		
	1.5	Load capacity/load	Q kg	1600		
	1.6	Load centre distance	c mm	600		
	1.8	Load distance, centre of drive axle to fork	x mm	801	951	
	1.9	Wheelbase	y mm	1039	1189	
	Weights	2.1.1	Service weight (incl. battery)	kg	145	149
2.2		Axle load laden front/rear	kg	680 / 1065	682 / 1067	682 / 1071
2.3		Axle load unladen front/rear	kg	111 / 34	115 / 34	119 / 34
Wheels/suspension system	3.1	Tyres		Polyurethane (PU)		
	3.2	Tyre size, front		Ø210 x 70		
	3.3	Tyre size, rear		Ø80 x 70		
	3.4	Additional wheels		Ø80 x 30		
	3.5	Wheels, number front/back (x=driven)		1x +2 / 4		
	3.6	Tread width, front	b10 mm	420		
	3.7	Tread width, rear	b11 mm	380	525	
Basic dimensions	4.4	Lift (h3)	h3 mm	115		
	4.9	Height of tiller handle in drive position min./max.	h14 mm	780 / 1160		
	4.15	Height, lowered	h13 mm	80		
	4.19	Total length	l1 mm	1386	1536	
	4.20	Length including fork shank	l2 mm	386		
	4.21.1	total width	b1 mm	540	685	
	4.22	Fork dimensions	s/ e/l mm	47 x 160 x 1000	47 x 160 x 1150	
	4.25	Width across forks	b5 mm	540	685	
	4.32	Ground clearance centre of wheelbase	m2 mm	33		
	4.34.2	Aisle width (pallet 800x1200 length)	Ast mm	1856	2006	
4.35	Turning radius	Wa mm	1186	1336		
Performance data	5.1	Travel speed laden/unladen	km/h	4.8 / 5.2		
	5.2	Lift speed laden/unladen	m/s	0.02 / 0.02		
	5.3	Lowering speed laden/unladen	m/s	0.04 / 0.03		
	5.8	Max. gradeability laden/unladen	%	8 / 16		
	5.10	Service brake		electromagnetic		

E-motor/Electronics	6.1	Drive motor, performance S2 60 min	kW	0.75
	6.2	Lift motor, performance with S3	kW	0.8
	6.3	Battery according to DIN 43531/35/36		no
	6.4	Battery voltage/nominal capacity	V / Ah	48 / 20
	6.5	Battery weight	kg	7.5
	6.6	Energy consumption according to VDI cycle	kWh/h	0.25
Other	8.1	Type of drive control		Impulse/DC
	10.7	Schalldruckpegel nach EN12053	dB (A)	70

- This data sheet according to VDI guideline 2198 only states the technical values of the standard truck. Different tyres, other masts, additional equipment etc. may result in different values.

The German production facilities in
Norderstedt, Moosburg and Landsberg
are certified as well as our Genuine Parts
Center in Kaltenkirchen.

ISO 9001
ISO 14001

Jungheinrich fork lift trucks meet
European safety requirements.



 **JUNGHEINRICH**

The logo features a red upward-pointing arrow integrated into the letter 'J' of the word 'JUNGHEINRICH', which is written in a bold, black, sans-serif font.