



Electric ride-on/pedestrian pallet truck

ERE MA 120

Lift height: 120 mm / Load capacity: 2000 kg



ERE MA 120

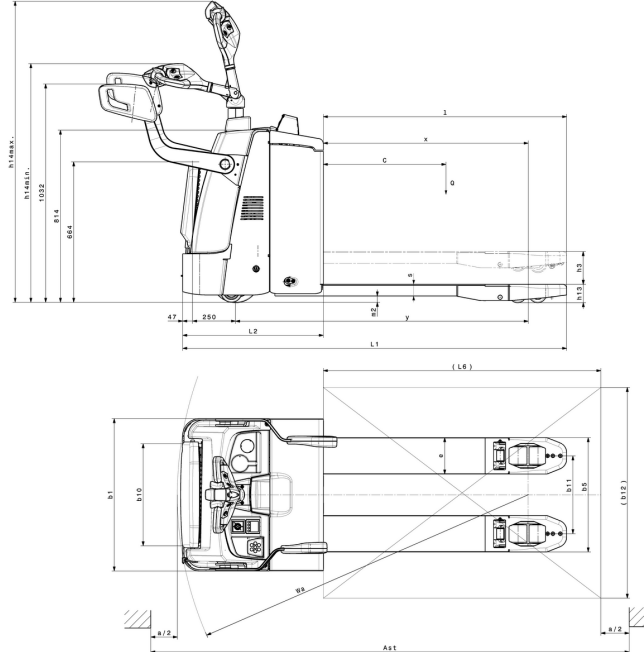

VDI table

Characteristic	1.1	Manufacturer (abbreviated description)		Jungheinrich
	1.2	Manufacturer's type designation		ERE MA
	1.3	Drive		Electric
	1.4	Operation		Stand-on/pedestrian
	1.5	Load capacity/load	Q kg	2000
	1.6	Load centre distance	c mm	600
	1.8	Load distance, centre of drive axle to fork	x mm	911
	1.9	Wheelbase	y mm	1327
	Weights	2.1.1	Service weight (incl. battery)	kg
2.2		Axle load laden front/rear	kg	905 / 1670
2.3		Axle load unladen front/rear	kg	440 / 135
Wheels/suspension system	3.1	Tyres		Polyurethane (PU)
	3.2	Tyre size, front		Ø 230 x 70
	3.3	Tyre size, rear		Ø 85 x 110 / Ø 85 x 85
	3.4	Additional wheels		Ø 100x40
	3.5	Wheels, number front/back (x=driven)		1x+2/2 or 4
	3.6	Tread width, front	b10 mm	508
	3.7	Tread width, rear	b11 mm	368
Basic dimensions	4.4	Lift (h3)	h3 mm	122
	4.9	Height of tiller handle in drive position min./max.	h14 mm	1180 / 1430
	4.15	Height, lowered	h13 mm	85
	4.19	total length	l1 mm	1815
	4.20	Length including fork shank	l2 mm	665
	4.21.1	total width	b1 mm	720
	4.21.2	total width	b2 mm	720
	4.22	Fork dimensions	s/e/l mm	55 x 172 x 1150
	4.25	Width across forks	b5 mm	540
	4.32	Ground clearance centre of wheelbase	m2 mm	30
	4.34.1	Aisle width (pallet 1000x1200 sideways)	Ast mm	2467
	4.34.2	Aisle width (pallet 800x1200 length)	Ast mm	2353
	4.35	Turning radius	Wa mm	1660
Performance data	5.1	Travel speed laden/unladen	km/h	6.5 / 6.5
	5.2	Lift speed laden/unladen	m/s	0.05 / 0.07
	5.3	Lowering speed laden/unladen	m/s	0.06 / 0.05
	5.7	Gradeability laden/unladen	%	8 / 16
	5.10	Service brake		generative

E-motor/Electronics	6.1	Drive motor, performance S2 60 min	kW	1
	6.2	Lift motor, performance with S3	kW	2.2
	6.3	Battery according to DIN 43531/35/36		DIN 43531 B
	6.4	Battery voltage/nominal capacity	V / Ah	24 / 180
	6.5	Battery weight	kg	180
	6.6.1	Energy consumption according to EN cycle	kWh/h	0.56
	6.6.2	CO2 equivalent as per EN 16796	kg/h	0.3
Other	8.1	Type of drive control		AC
	10.7	Sound level as per EN12053, operator's ear	dB (A)	65

- This data sheet according to VDI guideline 2198 only states the technical values of the standard truck. Different tyres, other masts, additional equipment etc. may result in different values.

- VDI no. 1.8: 1.9: 4.34.1: 4.34.2: 4.35: Load section lowered: +53mm
- VDI no. 4.34.1: Ast for intrusive stacking (empty pallet place): -368mm
- VDI no. 4.34.2: Ast for intrusive stacking (empty pallet place): -204mm
- VDI no. 4.19: 4.20: 4.34.1: 4.34.2: 4.35: with platform folded down +436mm

The German production facilities in
Norderstedt, Moosburg and Landsberg ISO 9001
are certified as well as our Genuine Parts ISO 14001
Center in Kaltenkirchen.

**JUNGHEINRICH**