



## Electric ride-on/pedestrian pallet truck

**ERE MB 220 / 225**

Lift height: 122 mm / Load capacity: 2000-2500 kg



# ERE MB 220 / 225

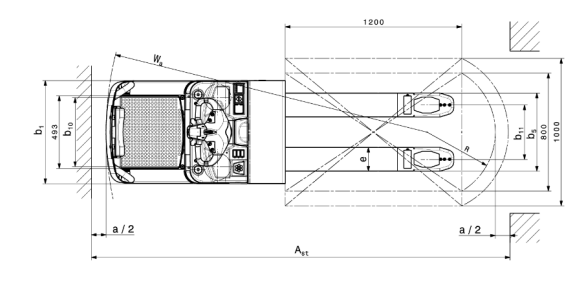
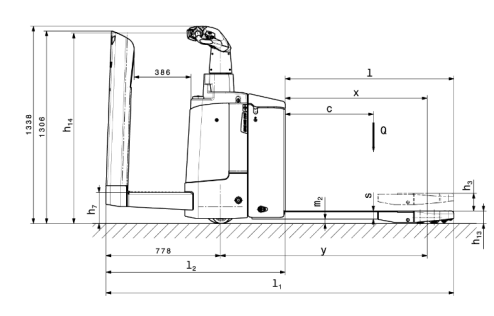
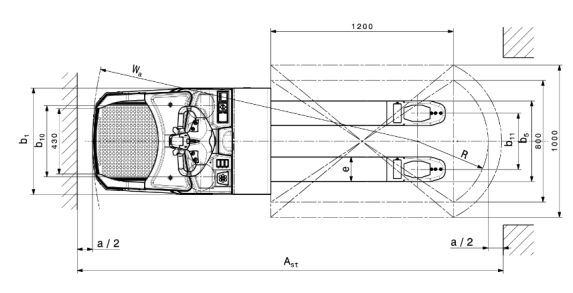
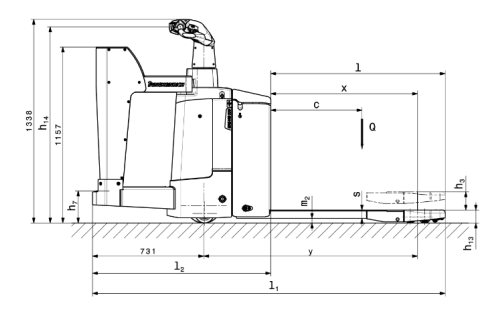
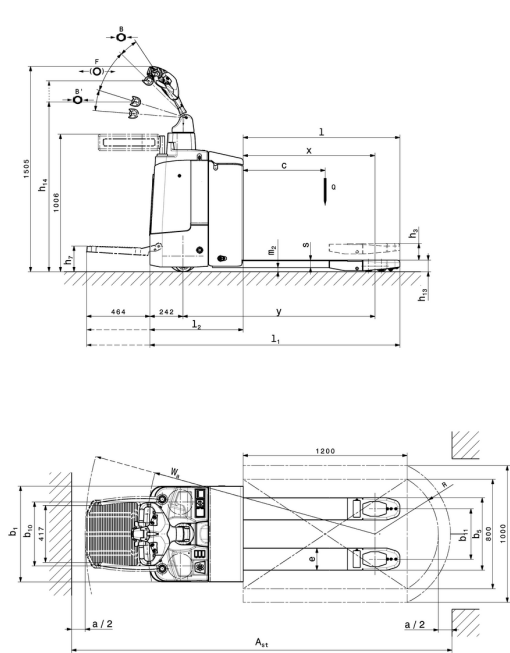

## VDI table

Characteristic	1.1	Manufacturer (abbreviated description)		Jungheinrich
	1.2	Manufacturer's type designation		ERE MB
	1.3	Drive		Electric
	1.4	Operation		Stand-on/pedestrian
	1.5	Load capacity/load	Q kg	2000   2500
	1.6	Load centre distance	c mm	600
	1.8	Load distance, centre of drive axle to fork	x mm	910
	1.9	Wheelbase	y mm	1405
	Weights	2.1.1	Service weight (incl. battery)	kg
2.2		Axle load laden front/rear	kg	1173 / 2147
2.3		Axle load unladen front/rear	kg	675 / 142
Wheels/suspension system	3.1	Tyres		Polyurethane (PU)
	3.2	Tyre size, front		Ø 230 x 70
	3.3	Tyre size, rear		Ø 85 x 100 / Ø 82 x 70
	3.4	Additional wheels		Ø 125 x 54
	3.5	Wheels, number front/back (x=driven)		1x+2/ 2 or 4
	3.6	Tread width, front	b10 mm	464
	3.7	Tread width, rear	b11 mm	368
Basic dimensions	4.4	Lift (h3)	h3 mm	122
	4.9	Height of tiller handle in drive position min./max.	h14 mm	1240 / 1400
	4.15	Height, lowered	h13 mm	85
	4.19	total length	l1 mm	1832
	4.20	Length including fork shank	l2 mm	682
	4.21.1	total width	b1 mm	700
	4.22	Fork dimensions	s/e/l mm	55 x 162 x 1150
	4.25	Width across forks	b5 mm	530
	4.32	Ground clearance centre of wheelbase	m2 mm	30
	4.34.1	Aisle width (pallet 1000x1200 sideways)	Ast mm	2476
	4.34.2	Aisle width (pallet 800x1200 length)	Ast mm	2364
4.35	Turning radius	Wa mm	1670	
Performance data	5.1	Travel speed laden/unladen	km/h	8.5 / 8.5   8 / 8.5
	5.2	Lift speed laden/unladen	m/s	0.05 / 0.07
	5.3	Lowering speed laden/unladen	m/s	0.06 / 0.05
	5.7	Gradeability laden/unladen	%	8 / 16
	5.10	Service brake		generative

E-motor/Electronics	6.1	Drive motor, performance S2 60 min	kW	1.6
	6.2	Lift motor, performance with S3	kW	2.2
	6.3	Battery according to DIN 43531/35/36		B
	6.4	Battery voltage/nominal capacity	V / Ah	24 / 250
	6.5	Battery weight	kg	212
	6.6.1	Energy consumption according to EN cycle	kWh/h	0.61
	6.6.2	CO2 equivalent as per EN 16796	kg/h	0.3
Other	8.1	Type of drive control		AC
	10.7	Sound level as per EN12053, operator's ear	dB (A)	69
<p>- This data sheet according to VDI guideline 2198 only states the technical values of the standard truck. Different tyres, other masts, additional equipment etc. may result in different values.</p>				

- VDI no. 1.8: 1.9: 4.34.1: 4.34.2: 4.35: Load section lowered: +55mm
- VDI no. 1.9: 4.19: 4.20: 4.34.1: 4.34.2: 4.35: Battery compartment L (375 Ah): +71mm
- VDI no. 4.34.1: Ast for intrusive stacking (empty pallet place): -366mm
- VDI no. 4.34.2: Ast for intrusive stacking (empty pallet place): -204mm
- VDI no. 4.19 for rear entry: 2319mm, for L shape: 2365 mm
- VDI no. 4.20 for rear entry: 1172mm, for L shape: 1218 mm
- VDI no. 4.34.1 for rear entry: 2942 mm, for L shape: 2988 mm
- VDI no. 4.34.2 for rear entry: 2830 mm, for L shape: 2876 mm
- VDI no. 4.35 for rear entry: 2136 mm, for L shape: 2182 mm

The German production facilities in  
Norderstedt, Moosburg and Landsberg  
are certified as well as our Genuine Parts  
Center in Kaltenkirchen. ISO 9001  
ISO 14001

 **JUNGHEINRICH**