



## Electric tow tractor EZS 130

**LION**  
technology

**JUNGHEINRICH**

# EZS 130

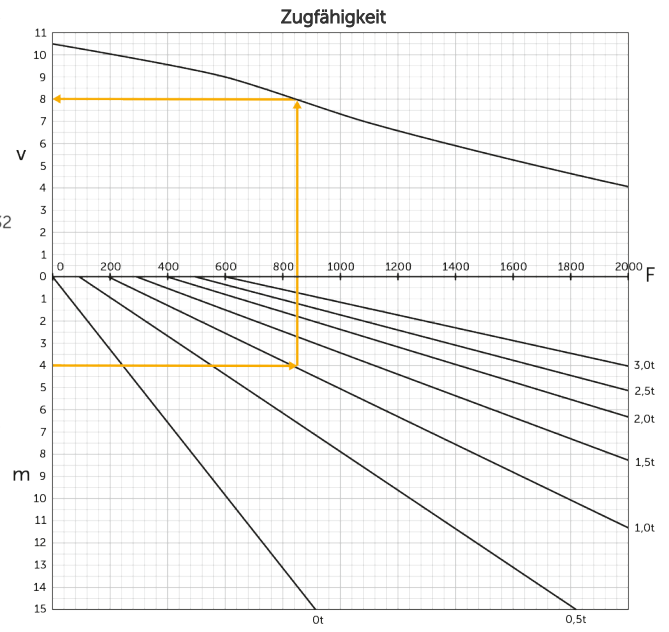
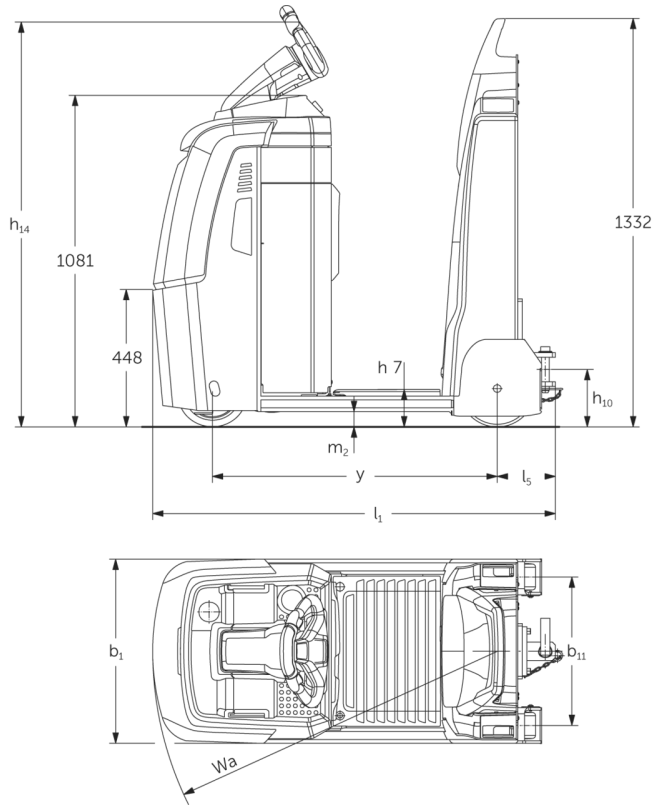

## VDI table

Kennzeichen	1.1	Hersteller (Kurzbezeichnung)		Jungheinrich
	1.2	Typzeichen des Herstellers		EZS 130
	1.3	Antrieb		electric
	1.4	Bedienung		Stand-on
	1.5.3	Towing capacity	Q kg	3000
	1.7	Nennzugkraft	N	600
	1.9	Radstand	y mm	930
Gewichte	2.1.1	Eigengewicht (inkl. Batterie)	kg	525
	2.3	Achslast ohne Last vorn/hinten	kg	320 / 205
Räder/Fahrwerk	3.1	Bereifung		Polyurethane / Super-elastic
	3.2	Reifengröße, vorn		ø230 x 78
	3.3	Reifengröße, hinten		ø250 x 80
	3.5	Wheels, number front/back (x=driven)		1 x / 2
	3.7	Spurweite, hinten	b11 mm	485
Grundabmessungen	4.8	Sitzhöhe/Standhöhe	h7 mm	122
	4.9	Höhe Deichselgriff in Fahrstellung min./max.	h14 mm	1320
	4.12	Kupplungshöhe	h10 mm	158
	4.19	Gesamtlänge	l1 mm	1315
	4.21.1	Gesamtbreite	b1 mm	600
	4.32	Bodenfreiheit Mitte Radstand	m2 mm	50
	4.35	Wenderadius	Wa mm	1126
Leistungsdaten	5.1	Fahrgeschwindigkeit mit/ohne Last	km/h	9 / 10.5
	5.1.1	Fahrgeschwindigkeit mit/ohne Last rückwärts	km/h	6 / 6
	5.5	Zugkraft mit Last	N	600
	5.6	Max. Zugkraft mit/ohne Last	N	2000 / 2000
	5.10	Betriebsbremse		electromagnetic/generative

E-Motor/Elektronik	6.1	Fahrmotor, Leistung S2 60 min	kW	2.8
	6.4	Batteriespannung/Nennkapazität	V / Ah	24 / 200
	6.5	Batteriegewicht	kg	185
	6.6.1	Energieverbrauch nach EN-Zyklus	kWh/h	0.75
	6.6.2	CO2 Äquivalent nach EN16796	kg/h	0.4
Sonstiges	8.1	Art der Fahrsteuerung		AC speedCONTROL
	10.5	Ausführung Lenkung		electric
	10.7	Schalldruckpegel nach EN12053	dB (A)	57
- This data sheet according to VDI guideline 2198 only states the technical values of the standard truck. Different tyres, other masts, additional equipment etc. may result in different values.				

- VDI no. 4.9: the height applies to the version with jetPILOT
- VDI no. 4.12: the value for the coupling height applies to a single plug-in coupling
- VDI no. 4.19: The specification for the overall length contains a single plug-in coupling

The German production facilities in  
Norderstedt, Moosburg and Landsberg  
are certified as well as our Genuine Parts  
Center in Kaltenkirchen.

ISO 9001  
ISO 14001

Jungheinrich fork lift trucks meet  
European safety requirements.



 **JUNGHEINRICH**

The logo features a red upward-pointing arrow integrated into the letter 'J' of the word 'JUNGHEINRICH', which is written in a bold, black, sans-serif font.