



Electric tow tractor **EZS 350**

LION
technology

JUNGHEINRICH

EZS 350

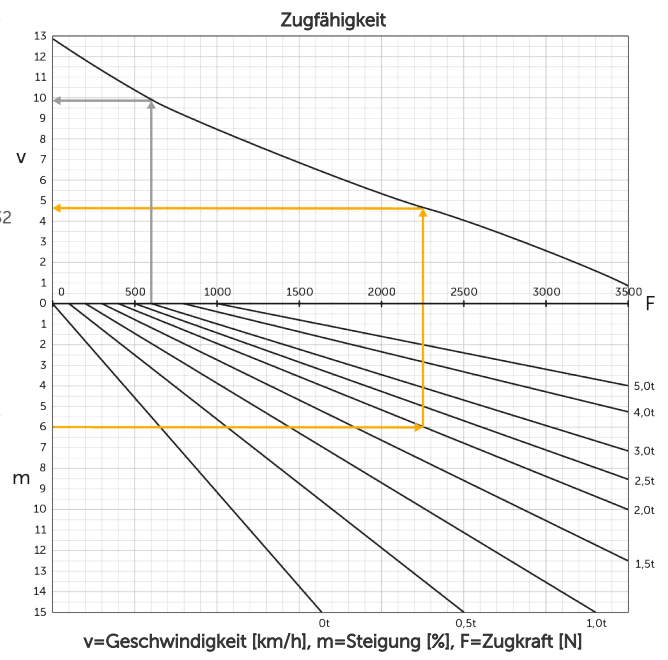
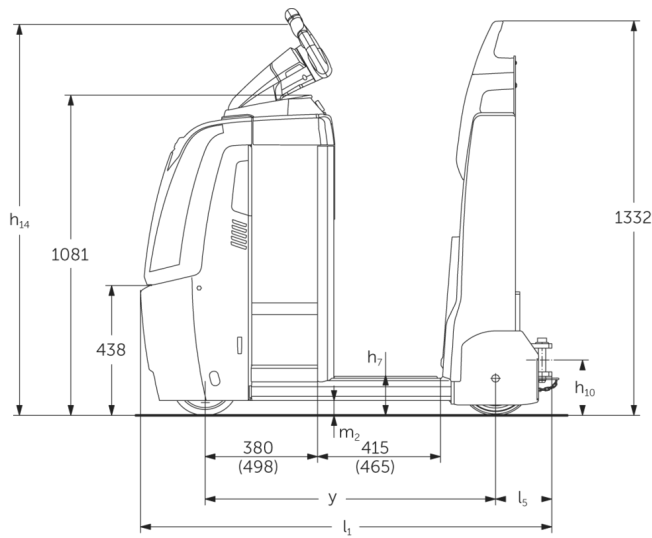

VDI table

Kennzeichen	1.1	Hersteller (Kurzbezeichnung)		Jungheinrich			
	1.2	Typzeichen des Herstellers		EZS 350 L Std	EZS 350 L Comfort	EZS 350 XL Std	EZS 350 XL Comfort
	1.3	Antrieb		electric			
	1.4	Bedienung		Stand-on			
	1.5.3	Towing capacity	Q kg	5000			
	1.7	Nennzugkraft	N	1000			
	1.9	Radstand	y mm	980	1030	1098	1148
Gewichte	2.1.1	Eigengewicht (inkl. Batterie)	kg	996	1006	1091	1101
	2.3	Achslast ohne Last vorn/hinten	kg	505 / 491	510 / 496	565 / 526	570 / 531
Räder/Fahwerk	3.1	Bereifung		Polyurethane / Super-elastic			
	3.2	Reifengröße, vorn		ø230 x 77			
	3.3	Reifengröße, hinten		ø250 x 80			
	3.5	Wheels, number front/back (x=driven)		1x/2			
	3.7	Spurweite, hinten	b11 mm	680			
Grundabmessungen	4.8	Sitzhöhe/Standhöhe	h7 mm	135			
	4.9	Höhe Deichselgriff in Fahrstellung min./max.	h14 mm	1320			
	4.12	Kupplungshöhe	h10 mm	158			
	4.19	Gesamtlänge	l1 mm	1390	1440	1508	1558
	4.21.1	Gesamtbreite	b1 mm	810			
	4.32	Bodenfreiheit Mitte Radstand	m2 mm	50			
	4.35	Wenderadius	Wa mm	1210	1260	1328	1378
Leistungsdaten	5.1	Fahrgeschwindigkeit mit/ohne Last	km/h	8 / 12.5			
	5.1.1	Fahrgeschwindigkeit mit/ohne Last rückwärts	km/h	6 / 6			
	5.5	Zugkraft mit Last	N	1000			
	5.6	Max. Zugkraft mit/ohne Last	N	3700 / 3700			
	5.10	Betriebsbremse		electromagnetic/generative			

E-Motor/Elektronik	6.1	Fahrmotor, Leistung S2 60 min	kW	2.8
	6.4	Batteriespannung/Nennkapazität	V / Ah	24 / 465
	6.5	Batteriegewicht	kg	370
	6.6.1	Energieverbrauch nach EN-Zyklus	kWh/h	1.15
	6.6.2	CO2 Äquivalent nach EN16796	kg/h	0.6
Sonstiges	8.1	Art der Fahrsteuerung		AC speedCONTROL
	10.7	Schalldruckpegel nach EN12053	dB (A)	66
- This data sheet according to VDI guideline 2198 only states the technical values of the standard truck. Different tyres, other masts, additional equipment etc. may result in different values.				

- VDI no. 4.9: the height applies to the version with jetPILOT
- VDI no. 4.12: the value for the coupling height applies to a single plug-in coupling. Other coupling heights are available
- VDI no. 4.19: as different coupling systems are available, the specification applies to the overall length including a single plug-in coupling
- VDI no. 5.1: see tow load diagram
- VDI no. 5.5: this value is the rated drawbar pull
- VDI no. 5.6: see tow load diagram

The German production facilities in
Norderstedt, Moosburg and Landsberg
are certified as well as our Genuine Parts
Center in Kaltenkirchen.

ISO 9001
ISO 14001

Jungheinrich fork lift trucks meet
European safety requirements.



 **JUNGHEINRICH**

The logo features a red upward-pointing arrow integrated into the letter 'J' of the word 'JUNGHEINRICH', which is written in a bold, black, sans-serif font.