



Electric three-wheel counterbalance forklift truck

EFG 112

Lift height: 2900-7000 mm / Load capacity: 1200 kg

LI-ION
technology

JUNGHEINRICH

EFG 112

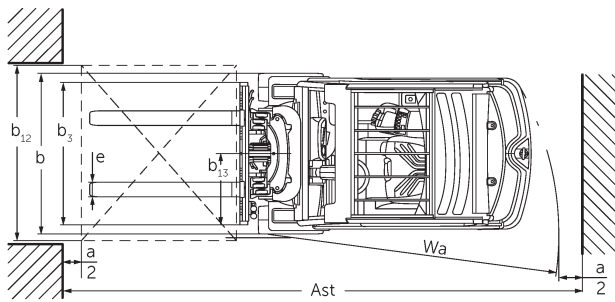
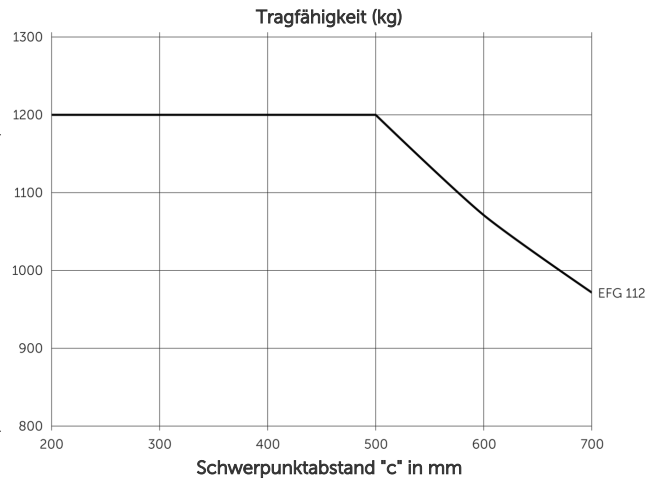
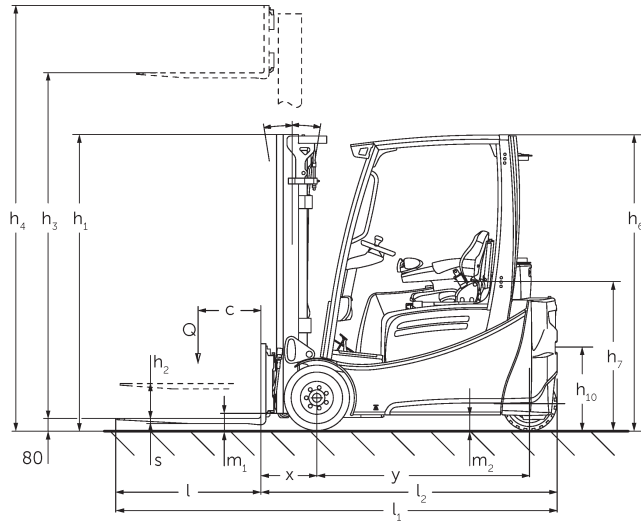

EFG 112

EFG 112	Lift (h3)	Retracted mast height (h1)	Free lift (h2)	Extended mast height (h4)	Neigung Hubgerüst vor/ zurück
Duplex mast ZT	3000 mm	2060 mm	150 mm	3590 mm	7 / 6 °
	3100 mm	2110 mm	150 mm	3690 mm	7 / 6 °
	3300 mm	2210 mm	150 mm	3890 mm	7 / 7 °
	3500 mm	2310 mm	150 mm	4090 mm	7 / 7 °
	3700 mm	2410 mm	150 mm	4290 mm	7 / 7 °
	4000 mm	2560 mm	150 mm	4590 mm	7 / 7 °
	4500 mm	2810 mm	150 mm	5090 mm	7 / 7 °
Duplex mast ZZ	2900 mm	1965 mm	1375 mm	3490 mm	7 / 6 °
	3100 mm	2065 mm	1475 mm	3690 mm	7 / 6 °
	3180 mm	2105 mm	1515 mm	3770 mm	7 / 7 °
	3300 mm	2165 mm	1575 mm	3890 mm	7 / 7 °
	3500 mm	2265 mm	1675 mm	4090 mm	7 / 7 °
	3700 mm	2365 mm	1775 mm	4290 mm	7 / 7 °
	4000 mm	2515 mm	1925 mm	4590 mm	7 / 7 °
Triplex mast DZ	4250 mm	1975 mm	1385 mm	4840 mm	7 / 4 °
	4400 mm	2025 mm	1435 mm	4990 mm	7 / 4 °
	4640 mm	2105 mm	1515 mm	5230 mm	7 / 5 °
	4700 mm	2125 mm	1535 mm	5290 mm	7 / 5 °
	4800 mm	2165 mm	1575 mm	5390 mm	7 / 5 °
	5000 mm	2235 mm	1645 mm	5590 mm	7 / 5 °
	5500 mm	2415 mm	1825 mm	6090 mm	7 / 5 °
	6000 mm	2585 mm	1995 mm	6590 mm	7 / 5 °
	6500 mm	2765 mm	2175 mm	7090 mm	7 / 5 °
7000 mm	2935 mm	2345 mm	7590 mm	7 / 5 °	

VDI table

Kennzeichen	1.1	Hersteller (Kurzbezeichnung)		Jungheinrich
	1.2	Typzeichen des Herstellers		EFG 112
	1.3	Antrieb		electric
	1.4	Bedienung		Seat
	1.5	Load capacity/load	Q kg	1200
	1.6	Lastschwerpunktabstand	c mm	500
	1.8	Lastabstand	x mm	344
	1.9	Radstand	y mm	1249
	Gewichte	2.1.1	Eigengewicht (inkl. Batterie)	kg
2.2		Achslast mit Last vorn/hinten	kg	3318 / 504
2.3		Achslast ohne Last vorn/hinten	kg	1307 / 1315
Räder/Fahrwerk	3.1	Bereifung		Super-elastic (SE)
	3.2	Reifengröße, vorn		18 x 7-8
	3.3	Reifengröße, hinten		140 / 55-9
	3.5	Wheels, number front/back (x=driven)		2x/2
	3.6	Spurweite, vorn	b10 mm	904
	3.7	Spurweite, hinten	b11 mm	176
	Grundabmessungen	4.1	Neigung Hubgerüst vor/zurück	a/β °
4.2		Retracted mast height (h1)	h1 mm	2060
4.3		Free lift (h2)	h2 mm	150
4.4		Lift (h3)	h3 mm	3000
4.5		Extended mast height (h4)	h4 mm	3590
4.7		Höhe Schutzdach (Kabine)	h6 mm	2040
4.8		Sitzhöhe/Standhöhe	h7 mm	920
4.12		Kupplungshöhe	h10 mm	560
4.19		Gesamtlänge	l1 mm	2933
4.20		Länge einschließlich Gabelrücken	l2 mm	1783
4.21.1		Gesamtbreite	b1 mm	1060
4.22		Fork dimensions	s/e/l mm	40 x 80 x 1150
4.23		Fork carriage connection class		2A
4.24		Gabelträgerbreite	b3 mm	980
4.31		Bodenfreiheit mit Last unter Hubgerüst	m1 mm	97
4.32		Bodenfreiheit Mitte Radstand	m2 mm	100
4.34.1		Arbeitsgangbreite (Palette 1000x1200 quer)	Ast mm	3112
4.34.2		Arbeitsgangbreite (Palette 800x1200 längs)	Ast mm	3235
4.35		Wenderadius	Wa mm	1440
4.36		Kleinster Drehpunktabstand	b13 mm	0

Leistungsdaten	5.1	Fahrgeschwindigkeit mit/ohne Last	km/h	12 / 12
	5.2	Hubgeschwindigkeit mit/ohne Last	m/s	0.3 / 0.48
	5.3	Senkgeschwindigkeit mit/ohne Last	m/s	0.55 / 0.55
	5.5	Zugkraft mit Last	N	2100
	5.6	Max. Zugkraft mit/ohne Last	N	9500 / 8000
	5.7	Steigfähigkeit mit/ohne Last	%	7.5 / 11
	5.8	Max. Steigfähigkeit mit/ohne Last	%	25 / 28
	5.9	Beschleunigungszeit mit/ohne Last	s	6.1 / 5.7
	5.10	Betriebsbremse		Reibbremse (mechanisch betätigt)
	E-Motor/Elektronik	6.1	Fahrmotor, Leistung S2 60 min	kW
6.1.1		2. Fahrmotor, Leistung S2 60 min	kW	2.8
6.2		Hubmotor, Leistung bei S3	kW	8.2
6.3		Batterie nach DIN 43531/35/36		DIN 43531 A
6.4		Batteriespannung/Nennkapazität	V / Ah	48 / 500
6.5		Batteriegewicht	kg	715
6.6.1		Energieverbrauch nach EN-Zyklus	kWh/h	3.4
6.6.2		CO2 Äquivalent nach EN16796	kg/h	1.8
6.7		Umschlagleistung	t/h	80
6.8.1	Energieverbrauch bei max. Umschlagleistung	kWh/h	3.8	
Sonstiges	8.1	Art der Fahrsteuerung		Impulse/AC
	10.1	Arbeitsdruck für Anbaugerät	bar	230
	10.2	Ölstrom für Anbaugeräte	l/min	27
	10.7	Schalldruckpegel nach EN12053	dB (A)	65
	10.8	Anhängerkupplung, Art/Typ DIN		DIN 15170 H
- This data sheet according to VDI guideline 2198 only states the technical values of the standard truck. Different tyres, other masts, additional equipment etc. may result in different values.				

The German production facilities in
Norderstedt, Moosburg and Landsberg
are certified as well as our Genuine Parts
Center in Kaltenkirchen.

ISO 9001
ISO 14001

Jungheinrich fork lift trucks meet
European safety requirements.



 **JUNGHEINRICH**

The logo features a red upward-pointing arrow integrated into the letter 'J' of the word 'JUNGHEINRICH', which is written in a bold, black, sans-serif font.