



Electric three-wheel counterbalance forklift truck

EFG BB 216k

Lift height: 3000-6500 mm / Load capacity: 1600 kg

LI-ION
technology

JUNGHEINRICH

EFG BB 216k

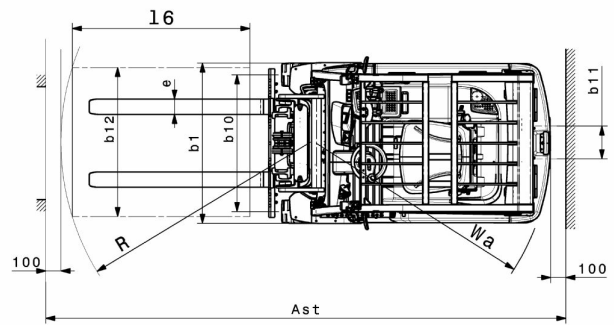
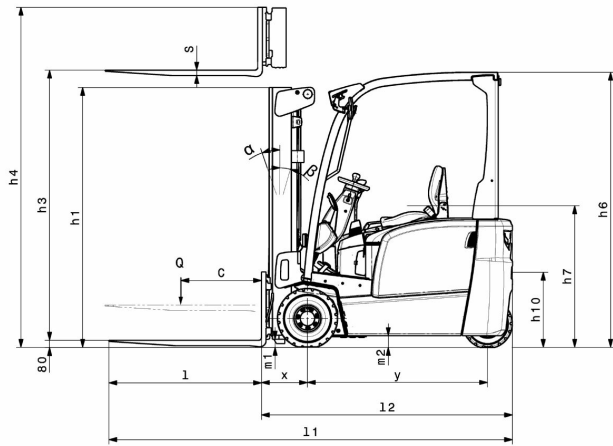

Tragfähigkeit (kg)

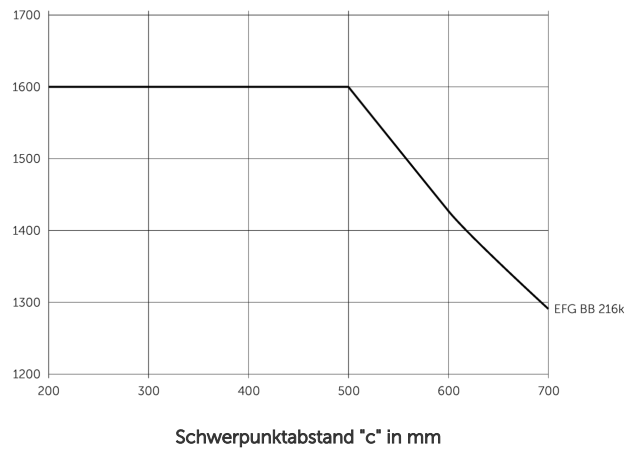

EFG BB 216k

EFG BB 216k	Lift (h3)	Retracted mast height (h1)	Free lift (h2)	Extended mast height (h4)	Neigung Hubgerüst vor/ zurück
Duplex mast ZT	3000 mm	2000 mm	150 mm	3555 mm	7 / 5 °
	3300 mm	2150 mm	150 mm	3855 mm	7 / 5 °
	3600 mm	2300 mm	150 mm	4155 mm	7 / 5 °
	4000 mm	2500 mm	150 mm	4555 mm	7 / 5 °
	4500 mm	2800 mm	150 mm	5055 mm	7 / 5 °
	5000 mm	3050 mm	150 mm	5555 mm	7 / 5 °
Duplex mast ZZ	3300 mm	2105 mm	1470 mm	3855 mm	7 / 5 °
	3600 mm	2255 mm	1620 mm	4155 mm	7 / 5 °
	4000 mm	2455 mm	1820 mm	4555 mm	7 / 5 °
Triplex mast DZ	4500 mm	2005 mm	1360 mm	5055 mm	7 / 5 °
	4800 mm	2105 mm	1460 mm	5355 mm	7 / 5 °
	5000 mm	2180 mm	1530 mm	5555 mm	7 / 5 °
	5500 mm	2355 mm	1710 mm	6055 mm	7 / 5 °
	6000 mm	2555 mm	1910 mm	6555 mm	7 / 5 °
	6500 mm	2805 mm	2160 mm	7055 mm	7 / 5 °

VDI table

Kennzeichen	1.1	Hersteller (Kurzbezeichnung)			Jungheinrich
	1.2	Typzeichen des Herstellers			EFG BB 216k
	1.3	Antrieb			electric
	1.4	Bedienung			Seat
	1.5	Load capacity/load	Q	kg	1600
	1.6	Lastschwerpunktabstand	c	mm	500
	1.8	Lastabstand	x	mm	352
	1.9	Radstand	y	mm	1357
	Gewichte	2.1.1	Eigengewicht (inkl. Batterie)		kg
2.2		Achslast mit Last vorn/hinten		kg	4102 / 544
2.3		Achslast ohne Last vorn/hinten		kg	1473 / 1571
Räder/Fahrwerk	3.1	Bereifung			Super-elastic (SE)
	3.2	Reifengröße, vorn			18 x 7 - 8
	3.3	Reifengröße, hinten			140 / 55 - 9
	3.5	Wheels, number front/back (x=driven)			2x / 2
	3.6	Spurweite, vorn	b10	mm	904
	3.7	Spurweite, hinten	b11	mm	211
	Grundabmessungen	4.1	Neigung Hubgerüst vor/zurück	a/β	°
4.2		Retracted mast height (h1)	h1	mm	2000
4.2.1		Gesamthöhe	h15	mm	2080
4.3		Free lift (h2)	h2	mm	150
4.4		Lift (h3)	h3	mm	3000
4.5		Extended mast height (h4)	h4	mm	3555
4.7		Höhe Schutzdach (Kabine)	h6	mm	2080
4.8		Sitzhöhe/Standhöhe	h7	mm	1030
4.12		Kupplungshöhe	h10	mm	560
4.12.1		2. Kupplungshöhe		mm	0
4.19		Gesamtlänge	l1	mm	2899
4.20		Länge einschließlich Gabelrücken	l2	mm	1899
4.21.1		Gesamtbreite	b1	mm	1060
4.22		Fork dimensions	s/e/l	mm	40 x 100 x 1000
4.23		Fork carriage connection class			2A
4.24		Gabelträgerbreite	b3	mm	980
4.31		Bodenfreiheit mit Last unter Hubgerüst	m1	mm	97
4.32		Bodenfreiheit Mitte Radstand	m2	mm	88
4.34.1		Arbeitsgangbreite (Palette 1000x1200 quer)	Ast	mm	3224
4.34.2		Arbeitsgangbreite (Palette 800x1200 längs)	Ast	mm	3348
4.35	Wenderadius	Wa	mm	1545	
4.36	Kleinster Drehpunktabstand	b13	mm	0	

Leistungsdaten	5.1	Fahrgeschwindigkeit mit/ohne Last	km/h	15 / 15
	5.2	Hubgeschwindigkeit mit/ohne Last	m/s	0.43 / 0.53
	5.3	Senkgeschwindigkeit mit/ohne Last	m/s	0.51 / 0.55
	5.5	Zugkraft mit Last	N	1300
	5.6	Max. Zugkraft mit/ohne Last	N	9000 / 9400
	5.7	Steigfähigkeit mit/ohne Last	%	6.5 / 14
	5.8	Max. Steigfähigkeit mit/ohne Last	%	13.5 / 16
	5.9	Beschleunigungszeit mit/ohne Last	s	5.5 / 5
	5.10	Betriebsbremse		mechanical/hydraulic
	E-Motor/Elektronik	6.1	Fahrmotor, Leistung S2 60 min	kW
6.1.1		2. Fahrmotor, Leistung S2 60 min	kW	3.7
6.2		Hubmotor, Leistung bei S3	kW	10
6.3		Batterie nach DIN 43531/35/36		DIN 43531 A
6.4		Batteriespannung/Nennkapazität	V / Ah	48 / 500
6.5		Batteriegewicht	kg	708
6.6.1		Energieverbrauch nach EN-Zyklus	kWh/h	4.25
6.6.2		CO2 Äquivalent nach EN16796	kg/h	2.3
6.7		Umschlagleistung	t/h	113
6.8.1		Energieverbrauch bei max. Umschlagleistung	kWh/h	5.13
Sonstiges	8.1	Art der Fahrsteuerung		Impulse/AC
	10.1	Arbeitsdruck für Anbaugerät	bar	230
	10.2	Ölstrom für Anbaugeräte	l/min	24
	10.7	Schalldruckpegel nach EN12053	dB (A)	75
	10.8	Anhängerkupplung, Art/Typ DIN		Bolts

- This data sheet according to VDI guideline 2198 only states the technical values of the standard truck. Different tyres, other masts, additional equipment etc. may result in different values.

The German production facilities in
Norderstedt, Moosburg and Landsberg
are certified as well as our Genuine Parts
Center in Kaltenkirchen.

ISO 9001
ISO 14001

Jungheinrich fork lift trucks meet
European safety requirements.



 **JUNGHEINRICH**

The logo features a red upward-pointing arrow integrated into the letter 'J' of the word 'JUNGHEINRICH', which is written in a bold, black, sans-serif font.