



## **Electric pedestrian stacker** **ERC 214i-216i**

Lift height: 2400-6000 mm / Load capacity: 1400-1600 kg



# ERC 214i-216i

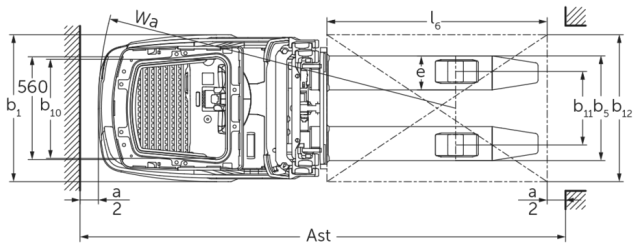
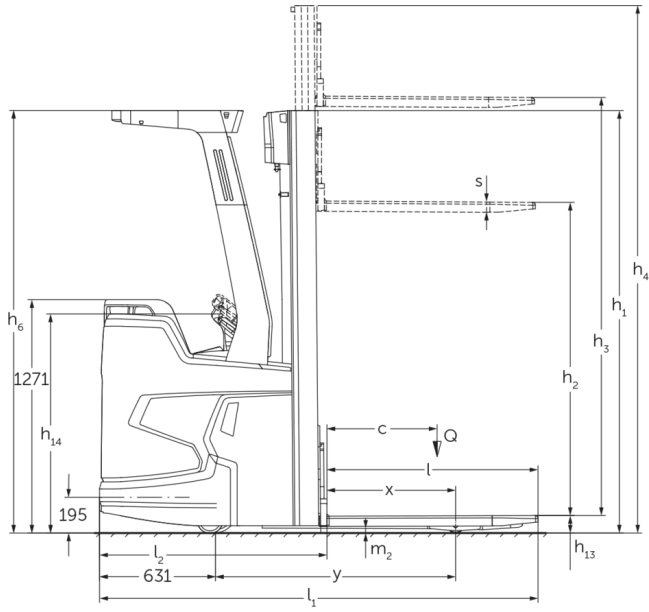

# ERC 214i-216i

ERC 214i	Lift (h3)	Retracted mast height (h1)	Free lift (h2)	Extended mast height (h4)
Duplex mast ZT	2500 mm	1800 mm	100 mm	3025 mm
	2760 mm	1930 mm	100 mm	3285 mm
	2900 mm	2000 mm	100 mm	3425 mm
	3160 mm	2130 mm	100 mm	3685 mm
	3600 mm	2350 mm	100 mm	4125 mm
	4100 mm	2600 mm	100 mm	4625 mm
	4300 mm	2700 mm	100 mm	4825 mm
Triplex mast DZ	4090 mm	1880 mm	1348 mm	4622 mm
	4300 mm	1950 mm	1418 mm	4832 mm
	4690 mm	2080 mm	1548 mm	5222 mm
	5350 mm	2300 mm	1768 mm	5882 mm
ERC 214i, ERC 216i	Lift (h3)	Retracted mast height (h1)	Free lift (h2)	Extended mast height (h4)
Triplex mast DZ	6000 mm	2550 mm	1968 mm	6582 mm
ERC 216i	Lift (h3)	Retracted mast height (h1)	Free lift (h2)	Extended mast height (h4)
Duplex mast ZT	2400 mm	1800 mm	100 mm	2975 mm
	2660 mm	1930 mm	100 mm	3235 mm
	2800 mm	2000 mm	100 mm	3375 mm
	3060 mm	2130 mm	100 mm	3635 mm
	3500 mm	2350 mm	100 mm	4075 mm
	4000 mm	2600 mm	100 mm	4575 mm
	4200 mm	2700 mm	100 mm	4775 mm
Triplex mast DZ	3990 mm	1880 mm	1298 mm	4572 mm
	4200 mm	1950 mm	1368 mm	4782 mm
	4590 mm	2080 mm	1498 mm	5172 mm
	5250 mm	2300 mm	1718 mm	5832 mm

## VDI table

Kennzeichen	1.1	Hersteller (Kurzbezeichnung)		Jungheinrich	
	1.2	Typzeichen des Herstellers		ERC 214i	ERC 216i
	1.3	Antrieb		electric	
	1.4	Bedienung		Operator platform	
	1.5	Load capacity/load	Q kg	1400	1600
	1.6	Lastschwerpunktstand	c mm	600	
	1.8	Lastabstand	x mm	694	
	1.9	Radstand	y mm	1308	
	Gewichte	2.1.1	Eigengewicht (inkl. Batterie)	kg	1470
2.2		Achslast mit Last vorn/hinten	kg	1195 / 1675	1210 / 1870
2.3		Achslast ohne Last vorn/hinten	kg	1085 / 385	1090 / 390
Räder/Fahrwerk	3.1	Bereifung		Polyurethane (PU)	
	3.2	Reifengröße, vorn		Ø 230x77	Ø 230 x 77
	3.3	Reifengröße, hinten		Ø 85 x 75	
	3.4	Zusatzräder		Ø 140 x 57	
	3.5	Wheels, number front/back (x=driven)		1x + 1 / 4	
	3.6	Spurweite, vorn	b10 mm	535	
	3.7	Spurweite, hinten	b11 mm	400	
Grundabmessungen	4.2	Retracted mast height (h1)	h1 mm	2300	
	4.3	Free lift (h2)	h2 mm	1768	1718
	4.4	Lift (h3)	h3 mm	5350	5250
	4.5	Extended mast height (h4)	h4 mm	5882	5832
	4.7	Höhe Schutzdach (Kabine)	h6 mm	2300	
	4.9	Höhe Deichselgriff in Fahrstellung min./max.	h14 mm	1185 / 1245	
	4.15	Höhe gesenkt	h13 mm	90	
	4.19	Gesamtlänge	l1 mm	2389	
	4.20	Länge einschließlich Gabelrücken	l2 mm	1239	
	4.21.1	Gesamtbreite	b1 mm	800	
	4.22	Fork dimensions	s/e/ l mm	56 x 185 x 1150	
	4.25	Width across forks	b5 mm	570	
	4.32	Bodenfreiheit Mitte Radstand	m2 mm	26	
	4.34.1	Arbeitsgangbreite (Palette 1000x1200 quer)	Ast mm	2596	
	4.34.2	Arbeitsgangbreite (Palette 800x1200 längs)	Ast mm	2646	
4.35	Wenderadius	Wa mm	1947		

Leistungsdaten	5.1	Fahrgeschwindigkeit mit/ohne Last (Efficiency   drivePLUS)	km/h	7 / 7   9 / 12
	5.2	Hubgeschwindigkeit mit/ohne Last	m/s	0.19 / 0.35
	5.3	Senkgeschwindigkeit mit/ohne Last	m/s	0.43 / 0.49
	5.8	Max. Steigfähigkeit mit/ohne Last (Efficiency   drivePLUS)	%	- / -   8 / 16
	5.10	Betriebsbremse		generative
E-Motor/Elektronik	6.1	Fahrmotor, Leistung S2 60 min (Efficiency   drivePLUS)	kW	-   3.2
	6.2	Hubmotor, Leistung bei S3	kW	3
	6.3	Batterie nach DIN 43531/35/36		Jungheinrich Li-ion
	6.4	Batteriespannung/Nennkapazität	V / Ah	24 / 260
	6.5	Batteriegewicht	kg	98
	6.6	Energieverbrauch nach VDI-Zyklus	kWh/h	0
	6.6.1	Energieverbrauch nach EN-Zyklus (Efficiency   PLUS)	kWh/h	-   0.96
	6.6.2	CO2 Äquivalent nach EN16796 (Efficiency   PLUS)	kg/h	-   0.5
	6.7	Umschlagleistung (Efficiency   PLUS)	t/h	-   83
	6.8.1	Energieverbrauch bei max. Umschlagleistung (Efficiency   PLUS)	kWh/h	-   2.31
Sonstiges	8.1	Art der Fahrsteuerung		AC
	10.7	Schalldruckpegel nach EN12053	dB (A)	68

- This data sheet according to VDI guideline 2198 only states the technical values of the standard truck. Different tyres, other masts, additional equipment etc. may result in different values.

The values in the table apply for the 260-Ah Li-ion battery, DZ 5350 / DZ 5250 mast, with overhead guard, without bumper.

- VDI no. 1.8: with lowered support arms: x + 53 mm; with duplex telescopic mast: x + 32 mm
- VDI no. 1.9: with lowered support arms: y + 51 mm
- VDI no. 4.19: with duplex telescopic mast: l1 - 32 mm
- VDI no. 4.20: with duplex telescopic mast: l2 - 32 mm
- VDI no. 4.34.1: diagonal as per VDI: aisle width + 225 mm; with duplex telescopic mast: aisle width - 32 mm
- VDI no. 4.34.2: diagonal as per VDI: aisle width + 146 mm; with duplex telescopic mast: aisle width - 32 mm
- VDI no. 6.2: with S3 = 11%
- VDI no. 6.5: with 130-Ah battery = 76 kg

The German production facilities in  
Norderstedt, Moosburg and Landsberg  
are certified as well as our Genuine Parts  
Center in Kaltenkirchen.

ISO 9001  
ISO 14001

Jungheinrich fork lift trucks meet  
European safety requirements.



 **JUNGHEINRICH**

The logo features a red upward-pointing arrow integrated into the letter 'J' of the word 'JUNGHEINRICH', which is written in a bold, black, sans-serif font.