



Medium/high level order picker

EKS 110

Lift height: 1000-2800 mm / Load capacity: 1000 kg

EKS 110



Abbildung zeigt EKS 110 Z 280 ZZ



Abbildung zeigt EKS 110 L 100 E

VDI table

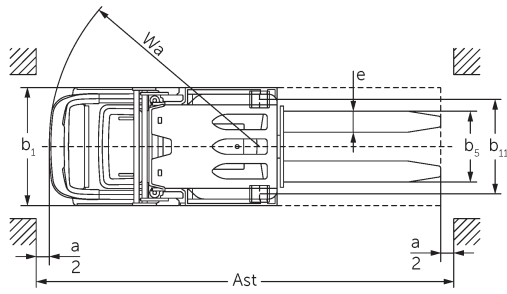
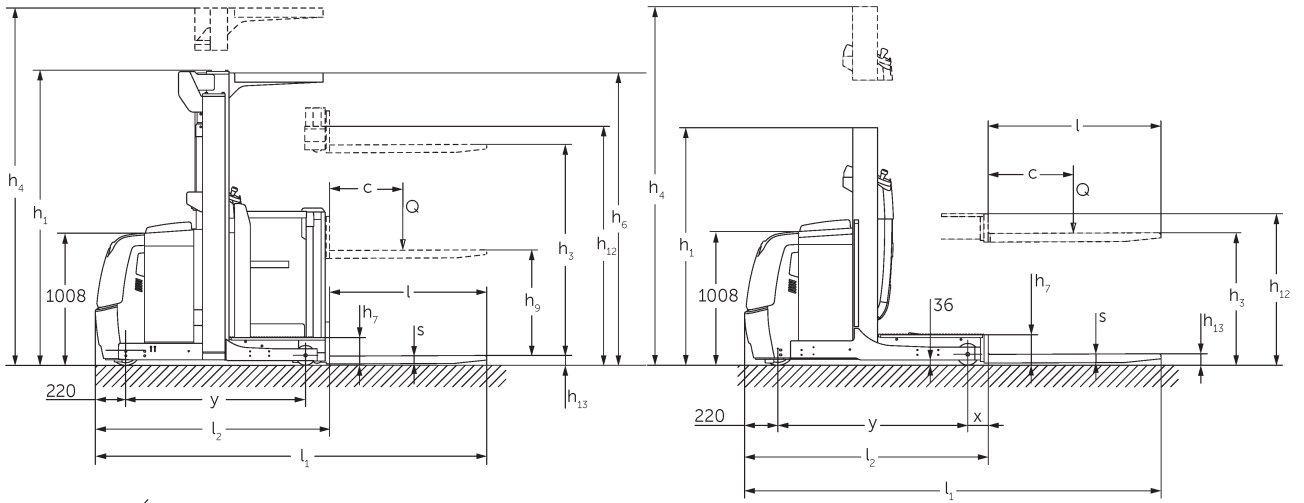
		Jungheinrich								
		EKS 110 L 100 E	EKS 110 L 160 E	EKS 110 L 190 E	EKS 110 L 280 ZZ	EKS 110 Z 100 E	EKS 110 Z 160 E			
Characteristic	1.1	Manufacturer (abbreviated description)								
	1.2	Manufacturer's type designation								
	1.3	Drive type	electric							
	1.4	Operation	Order pickers							
	1.5	Load capacity/load	Q	kg	1000					
	1.6	Load centre distance	c	mm	600					
	1.8	Load distance, centre of drive axle to fork	x	mm	143			180	148	
	1.9	Wheelbase	y	mm	1330			1385	1330	
	Weights	2.1.1	Service weight (incl. battery)	kg	1661	1785	1813	2268	1763	1907
2.2		Axle load laden front/rear	kg	491 / 2170	516 / 2269	506 / 2307	762 / 2506	489 / 2274	508 / 2399	
2.3		Axle load unladen front/rear	kg	1053 / 608	1093 / 692	1084 / 729	1336 / 932	1062 / 701	1083 / 824	
Wheels/suspension system	3.1	Tyres	Vulkollan®							
	3.2	Tyre size, front	ø 230 x 80							
	3.3	Tyre size, rear	ø 150 x 130							
	3.5	Wheels, number front/back (x=driven)	1x / 2							
	3.7	Tread width, rear	b11	mm	630			720	630	
Basic dimensions	4.2	Retracted mast height (h1)	h1	mm	1650	2260	2560	2250	1650	2260
	4.4	Lift (h3)	h3	mm	1000	1600	1900	2800	1000	1600
	4.5	Extended mast height (h4)	h4	mm	2650	3830	4130	5030	2650	3830
	4.7	Height of overhead guard (cab)	h6	mm	-	2230			-	2230
	4.8.1	Stand height	h7	mm	200					
	4.11	Additional lift	h9	mm	-				800	
	4.14	Stand height, elevated	h12	mm	1200	1800	2100	3000	1200	1800
	4.15	Height, lowered	h13	mm	80					
	4.19	Total length	l1	mm	2890			2980	2895	
	4.20	Length including fork shank	l2	mm	1690			1780	1695	
	4.21.1	total width	b1	mm	810			900	810	
	4.22	Fork dimensions	s/ e/l	mm	60 x 160 x 1200					
	4.25	Width across forks	b5	mm	540					
	4.26	Width between support arms/ loading areas	b4	mm	430			520	430	
	4.27	Width over guide rollers	b6	mm	970			1060	970	
4.31	Ground clearance laden under mast	m1	mm	35						
4.34.1	Aisle width (pallet 1000x1200 sideways)	Ast	mm	3039			3127	3039		

	4.34.2	Aisle width (pallet 800x1200 length)	Ast mm	3149		3240	3154		
	4.35	Turning radius	Wa mm	1548		1603	1548		
Performance data	5.1	Travel speed laden/unladen (Efficiency drivePLUS)	km/h	9 / 10 10 / 13	9 / 9 10 / 12	9 / 9 9.5 / 12	9 / 9 9 / 11	9 / 10 10 / 13	9 / 9 10 / 12
	5.2	Lift speed laden/unladen	m/s	0.19 / 0.26		0.15 / 0.2		0.23 / 0.31	
	5.3	Lowering speed laden/unladen	m/s	0.24 / 0.24		0.23 / 0.22		0.28 / 0.26	
	5.7	Gradeability laden/unladen	%	5 / 10					
	5.10	Service brake		generative					
	5.11	Parking brake		Electromagnetic spring-loaded brake system					
E-motor/Electronics	6.1	Drive motor, performance S2 60 min	kW	3.2					
	6.2	Lift motor, performance with S3	kW	3		6	3		
	6.3	Battery according to DIN 43531/35/36		DIN 43535 B					
	6.4	Battery voltage/nominal capacity	V / Ah	24 / 620					
	6.5	Battery weight	kg	480					
	6.6.1	Energy consumption according to EN cycle	kWh/h	0.42					
Other	8.1	Type of drive control		AC					
	10.5	Steering version		Electric power steering					
	10.7	Schalldruckpegel nach EN12053	dB (A)	61					
- This data sheet according to VDI guideline 2198 only states the technical values of the standard truck. Different tyres, other masts, additional equipment etc. may result in different values.									

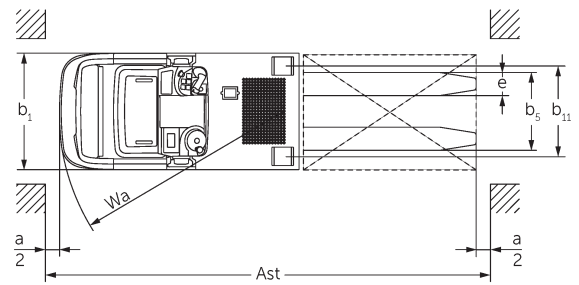
Characteristic	1.1	Manufacturer (abbreviated description)		Jungheinrich	
	1.2	Manufacturer's type designation		EKS 110 Z 190 E	EKS 110 Z 280 ZZ
	1.3	Drive type		electric	
	1.4	Operation		Order pickers	
	1.5	Load capacity/load	Q kg	1000	
	1.6	Load centre distance	c mm	600	
	1.8	Load distance, centre of drive axle to fork	x mm	148	185
	1.9	Wheelbase	y mm	1330	1385
	Weights	2.1.1	Service weight (incl. battery)	kg	1953
2.2		Axle load laden front/rear	kg	504 / 2449	754 / 2636
2.3		Axle load unladen front/rear	kg	1079 / 874	1328 / 1062

Wheels/suspension system	3.1	Tyres		Vulkollan ®	
	3.2	Tyre size, front		ø 230 x 80	
	3.3	Tyre size, rear		ø 150 x 130	
	3.5	Wheels, number front/back (x=driven)		1x / 2	
	3.7	Tread width, rear	b11 mm	630	720
Basic dimensions	4.2	Retracted mast height (h1)	h1 mm	2560	2250
	4.4	Lift (h3)	h3 mm	1900	2800
	4.5	Extended mast height (h4)	h4 mm	4130	5030
	4.7	Height of overhead guard (cab)	h6 mm	2230	
	4.8.1	Stand height	h7 mm	200	
	4.11	Additional lift	h9 mm	800	
	4.14	Stand height, elevated	h12 mm	2100	3000
	4.15	Height, lowered	h13 mm	80	
	4.19	Total length	l1 mm	2895	2985
	4.20	Length including fork shank	l2 mm	1695	1785
	4.21.1	total width	b1 mm	810	900
	4.22	Fork dimensions	s/e/ l mm	60 x 160 x 1200	
	4.25	Width across forks	b5 mm	540	
	4.26	Width between support arms/loading areas	b4 mm	430	520
	4.27	Width over guide rollers	b6 mm	970	1060
	4.31	Ground clearance laden under mast	m1 mm	35	
	4.34.1	Aisle width (pallet 1000x1200 sideways)	Ast mm	3039	3127
4.34.2	Aisle width (pallet 800x1200 length)	Ast mm	3154	3245	
4.35	Turning radius	Wa mm	1548	1603	
Performance data	5.1	Travel speed laden/unladen (Efficiency drivePLUS)	km/h	9 / 9 9.5 / 12	9 / 9 9 / 11
	5.2	Lift speed laden/unladen	m/s	0.15 / 0.2	0.23 / 0.31
	5.3	Lowering speed laden/unladen	m/s	0.23 / 0.22	0.28 / 0.26
	5.7	Gradeability laden/unladen	%	5 / 10	
	5.10	Service brake		generative	
	5.11	Parking brake		Electromagnetic spring-loaded brake system	
E-motor/Electronics	6.1	Drive motor, performance S2 60 min	kW	3.2	
	6.2	Lift motor, performance with S3	kW	3	6
	6.3	Battery according to DIN 43531/35/36		DIN 43535 B	
	6.4	Battery voltage/nominal capacity	V / Ah	24 / 620	
	6.5	Battery weight	kg	480	
	6.6.1	Energy consumption according to EN cycle	kWh/h	0.42	

Other	8.1	Type of drive control		AC
	10.5	Steering version		Electric power steering
	10.7	Schalldruckpegel nach EN12053	dB (A)	61
- This data sheet according to VDI guideline 2198 only states the technical values of the standard truck. Different tyres, other masts, additional equipment etc. may result in different values.				

- 4.2: L100E with overhead guard 2,230 mm
- 4.5: L100E with overhead guard 3,230 mm
- 4.7: L100E and Z100E overhead guard optional

The German production facilities in
Norderstedt, Moosburg and Landsberg
are certified as well as our Genuine Parts
Center in Kaltenkirchen.

ISO 9001
ISO 14001

Jungheinrich fork lift trucks meet
European safety requirements.



 **JUNGHEINRICH**

The logo features a red upward-pointing arrow integrated into the letter 'J' of the word 'JUNGHEINRICH', which is written in a bold, black, sans-serif font.