



Electric pedestrian stacker **EJC 110 / 112**

Lift height: 2500-4700 mm / Load capacity: 1000-1200 kg

JUNGHEINRICH

EJC 110 / 112

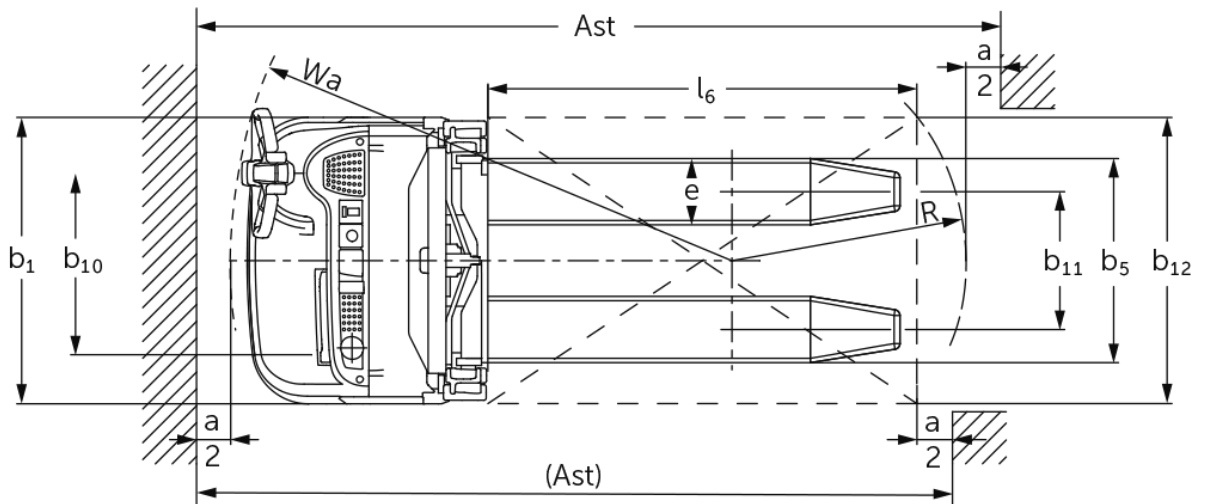
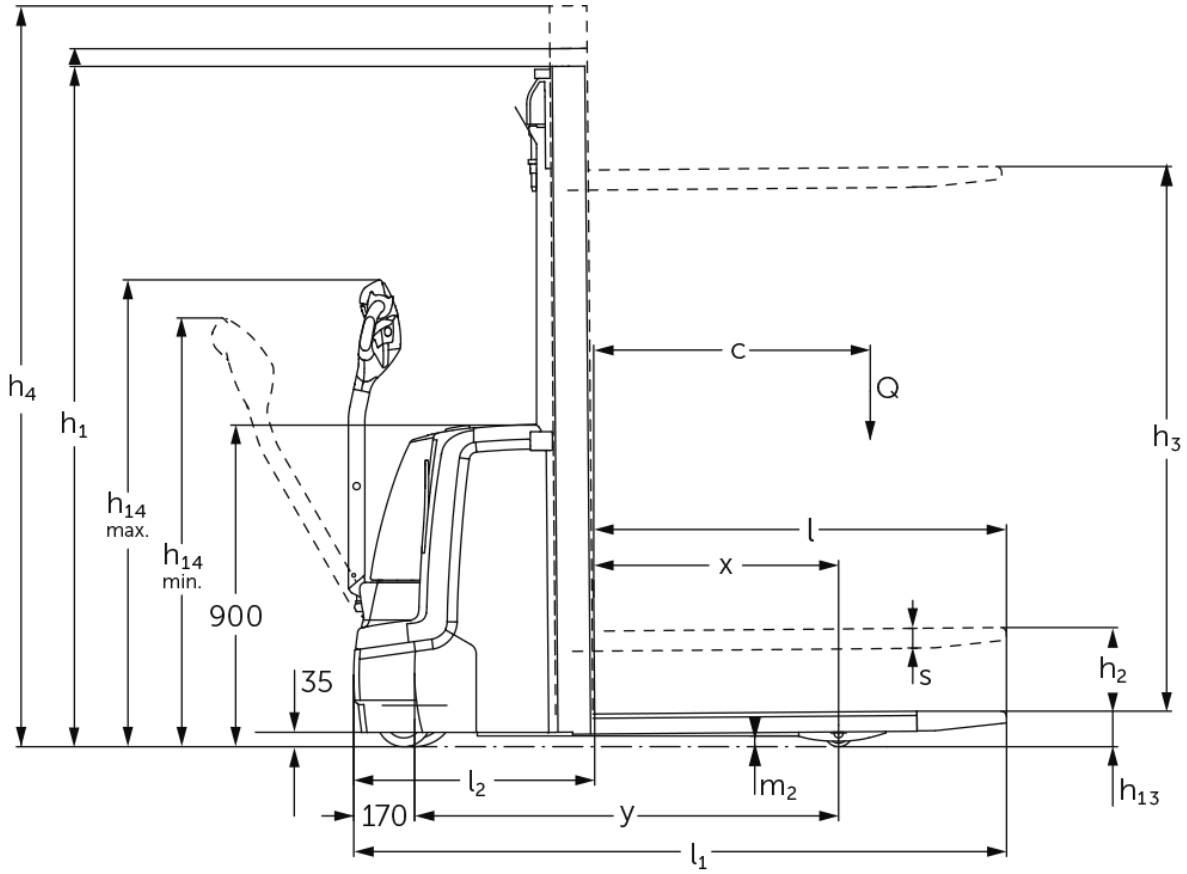

EJC 110 / 112

EJC 110		Lift (h3)	Retracted mast height (h1)	Free lift (h2)	Extended mast height (h4)
Duplex mast ZT	2500 mm	1750 mm	100 mm	2975 mm	
	2700 mm	1850 mm	100 mm	3175 mm	
	2900 mm	1950 mm	100 mm	3375 mm	
	3200 mm	2100 mm	100 mm	3675 mm	
	3600 mm	2300 mm	100 mm	4075 mm	
EJC 110, EJC 112		Lift (h3)	Retracted mast height (h1)	Free lift (h2)	Extended mast height (h4)
Duplex mast ZT	2500 mm	1750 mm	100 mm	2975 mm	
	2700 mm	1850 mm	100 mm	3175 mm	
	2900 mm	1950 mm	100 mm	3375 mm	
	3200 mm	2100 mm	100 mm	3675 mm	
	3600 mm	2300 mm	100 mm	4075 mm	
Duplex mast ZZ	2500 mm	1700 mm	1225 mm	2975 mm	
	2900 mm	1900 mm	1425 mm	3375 mm	
	3200 mm	2050 mm	1575 mm	3675 mm	
	3600 mm	2250 mm	1775 mm	4075 mm	
Triplex mast DZ	4090 mm	1845 mm	1338 mm	4597 mm	
	4300 mm	1915 mm	1408 mm	4807 mm	
EJC 112		Lift (h3)	Retracted mast height (h1)	Free lift (h2)	Extended mast height (h4)
Duplex mast ZT	4100 mm	2550 mm	100 mm	4575 mm	
	4300 mm	2650 mm	100 mm	4775 mm	
Duplex mast ZZ	4100 mm	2500 mm	2025 mm	4575 mm	
	4300 mm	2600 mm	2125 mm	4775 mm	
Triplex mast DZ	4700 mm	2050 mm	1543 mm	5207 mm	

VDI table

Characteristic	1.1	Manufacturer (abbreviated description)		Jungheinrich	
	1.2	Manufacturer's type designation		EJC 1	
	1.3	Drive		Electric	
	1.4	Operation		Pedestrian	
	1.5	Load capacity/load	Q kg	1000	1200
	1.6	Load centre distance	c mm	600	
	1.8	Load distance, centre of drive axle to fork	x mm	681	688
	1.9	Wheelbase	y mm	1184	1191
	Weights	2.1.1	Service weight (incl. battery)	kg	750
2.2		Axle load laden front/rear	kg	570 / 1180	650 / 1380
2.3		Axle load unladen front/rear	kg	510 / 240	580 / 250
Wheels/suspension system	3.1	Tyres		Polyurethane (PU)	
	3.2	Tyre size, front		Ø 230 x 70	
	3.3	Tyre size, rear		Ø 77 x 75	Ø 85 x 110
	3.4	Additional wheels		Ø 150 x 54	Ø 140 x 54
	3.5	Wheels, number front/back (x=driven)		1x +1/2	
	3.6	Tread width, front	b10 mm	507	
	3.7	Tread width, rear	b11 mm	415	400
Basic dimensions	4.2	Retracted mast height (h1)	h1 mm	1950	
	4.3	Free lift (h2)	h2 mm	100	
	4.4	Lift (h3)	h3 mm	2900	
	4.5	Extended mast height (h4)	h4 mm	3375	
	4.9	Height of tiller handle in drive position min./max.	h14 mm	850 / 1305	
	4.15	Height, lowered	h13 mm	90	
	4.19	total length	l1 mm	1822	
	4.20	Length including fork shank	l2 mm	672	
	4.21.1	total width	b1 mm	800	
	4.22	Fork dimensions	s/e/l mm	56 x 185 x 1150	
	4.25	Width across forks	b5 mm	570	
	4.32	Ground clearance centre of wheelbase	m2 mm	30	
	4.34.1	Aisle width (pallet 1000x1200 sideways)	Ast mm	2071	
	4.34.2	Aisle width (pallet 800x1200 length)	Ast mm	2121	
4.35	Turning radius	Wa mm	1402	1409	
Performance data	5.1	Travel speed laden/unladen	km/h	6 / 6	
	5.2	Lift speed laden/unladen	m/s	0.12 / 0.22	0.13 / 0.22
	5.3	Lowering speed laden/unladen	m/s	0.33 / 0.33	0.43 / 0.37
	5.8	Max. gradeability laden/unladen	%	8 / 16	
	5.10	Service brake		generative	

E-motor/Electronics	6.1	Drive motor, performance S2 60 min	kW	1	
	6.2	Lift motor, performance with S3	kW	1.7	2
	6.3	Battery according to DIN 43531/35/36		British Standard	
	6.4	Battery voltage/nominal capacity	V / Ah	24 / 200	
	6.5	Battery weight	kg	185	
	6.6	Energy consumption according to VDI cycle	kWh/h	0	
	6.6.1	Energy consumption according to EN cycle	kWh/h	0.61	0.66
	6.6.2	CO2 equivalent as per EN 16796	kg/h	0.3	0.4
Other	8.1	Type of drive control		AC	
	10.7	Sound level as per EN12053, operator's ear	dB (A)	62	
<p>- This data sheet according to VDI guideline 2198 only states the technical values of the standard truck. Different tyres, other masts, additional equipment etc. may result in different values.</p>					

The values in the table apply for the S-VBE (1-3) battery compartment, ZT2900 mast, battery 200 Ah.

- VDI no. 1.8: with DZ mast: x - 42 mm
- VDI no. 1.9: with M Li-ion battery compartment: y + 72 mm.
- VDI no. 4.19: with M Li-ion battery compartment: l1 + 72 mm. with DZ mast: l1 + 42 mm.
- VDI no. 4.20: with M Li-ion battery compartment: l2 + 72 mm. with DZ mast: l2 + 42 mm.
- VDI no. 4.34.1: with M Li-ion battery compartment: l2 + 72 mm. diagonal as per VDI: + 212 mm. with DZ mast: aisle width + 42 mm.
- VDI no. 4.34.2: with M Li-ion battery compartment: l2 + 72 mm. diagonal as per VDI: + 137 mm. with DZ mast: aisle width + 42 mm.
- VDI no. 4.35: with M Li-ion battery compartment: l2 + 72 mm.
- VDI no. 6.2: with EJC 110: S3 10%. With EJC 112: S3 12%.

The German production facilities in
Norderstedt, Moosburg and Landsberg
are certified as well as our Genuine Parts
Center in Kaltenkirchen. ISO 9001
ISO 14001

 **JUNGHEINRICH**