



Electric pedestrian stacker **EJC 110i / 112i**

Lift height: 1200-4700 mm / Load capacity: 1000-1200 kg



EJC 110i / 112i

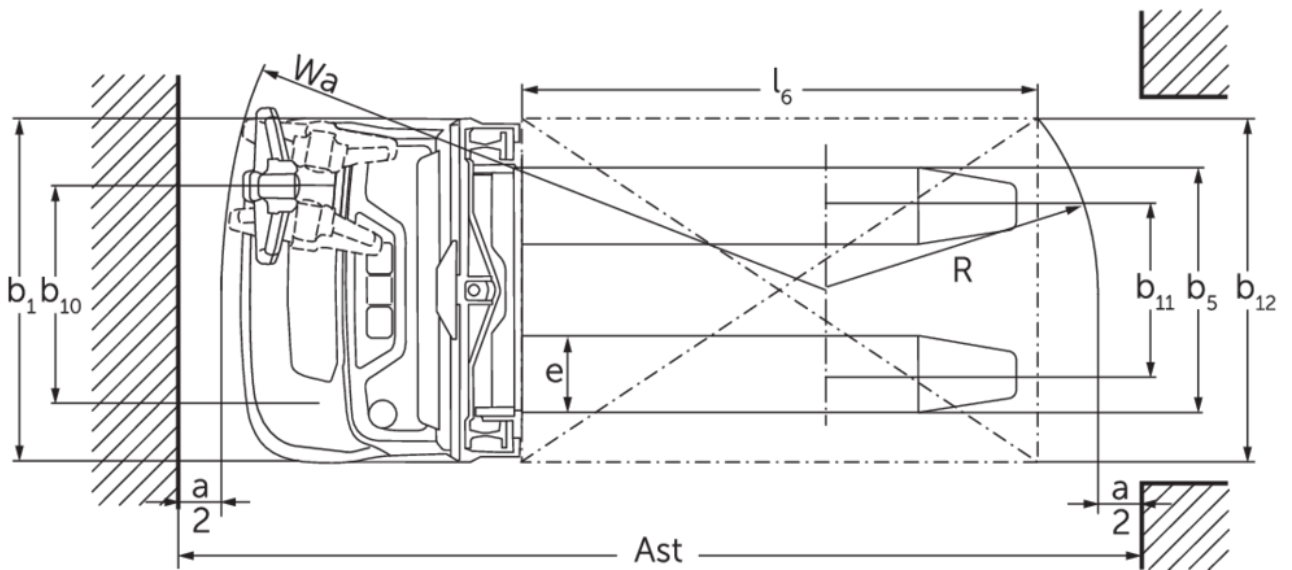
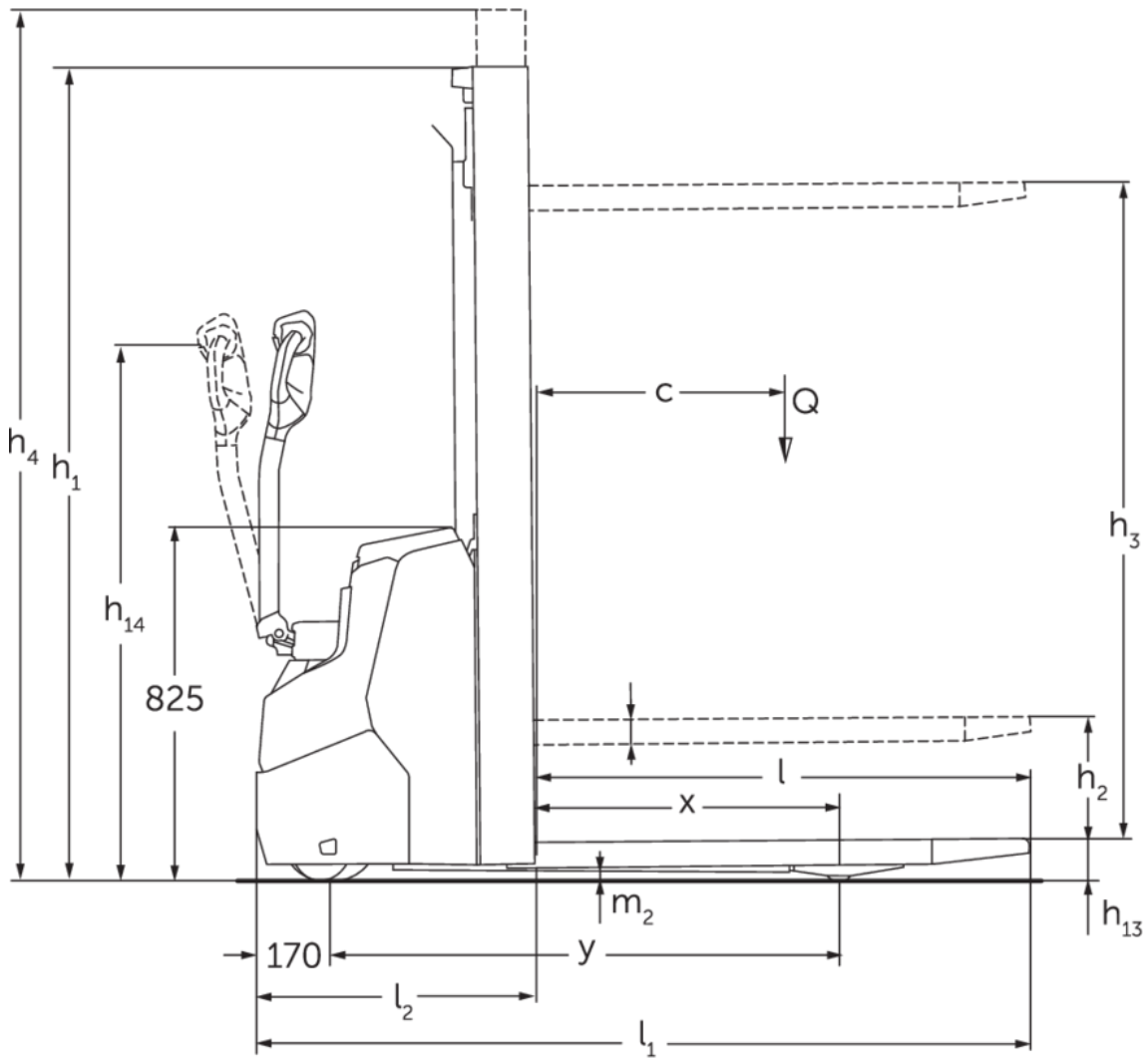

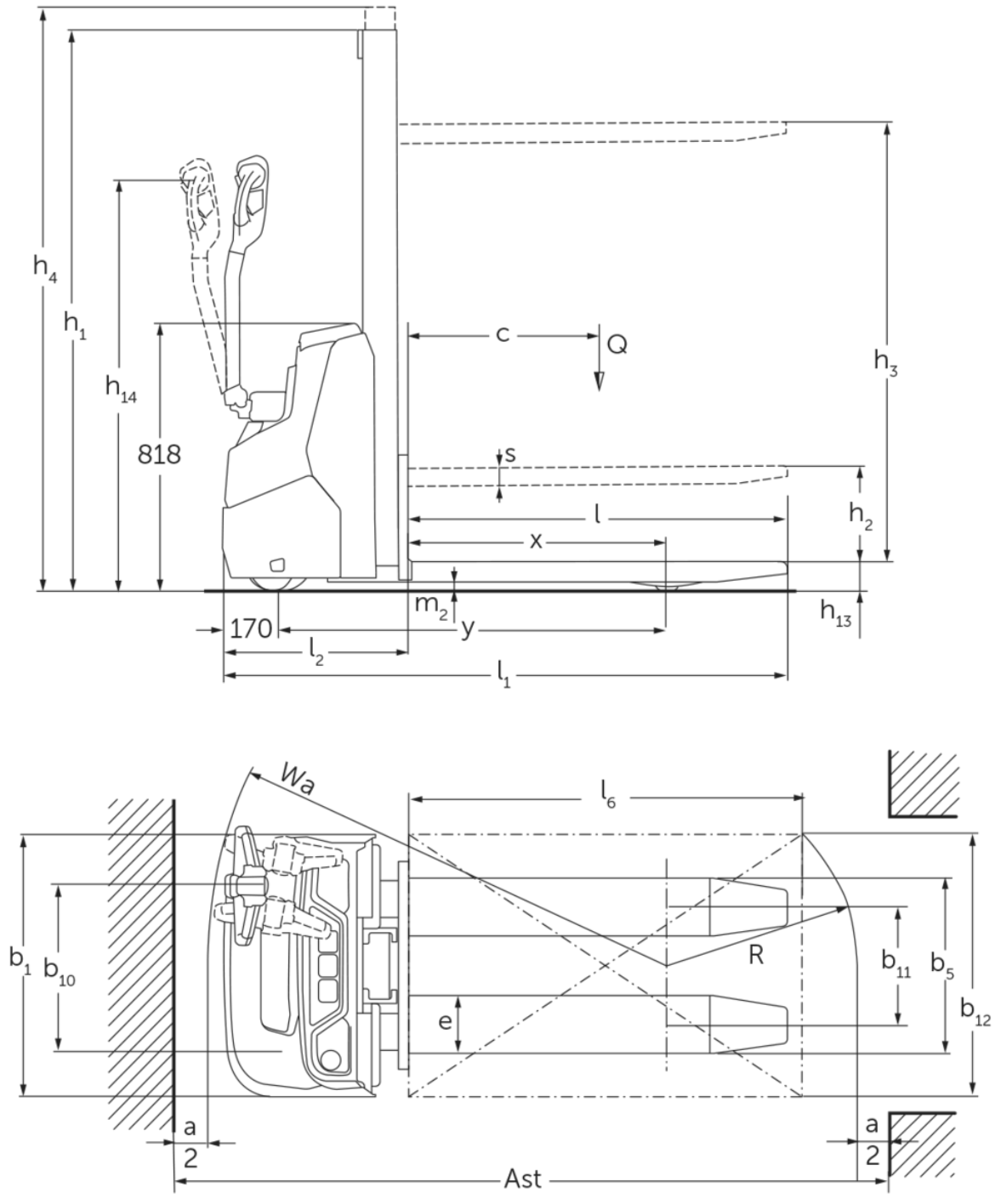

EJC 110i (E)

EJC 110i / 112i

EJC 110i (E)	Lift (h3)	Retracted mast height (h1)	Free lift (h2)	Extended mast height (h4)
Mono Mast MM	1200 mm	1710 mm	1200 mm	1710 mm
	1540 mm	1970 mm	1540 mm	1970 mm
	2000 mm	2430 mm	2000 mm	2430 mm
EJC 110i, EJC 112i	Lift (h3)	Retracted mast height (h1)	Free lift (h2)	Extended mast height (h4)
Duplex mast ZT	2300 mm	1650 mm	100 mm	2775 mm
	2500 mm	1750 mm	100 mm	2975 mm
	2700 mm	1850 mm	100 mm	3175 mm
	2900 mm	1950 mm	100 mm	3375 mm
	3200 mm	2100 mm	100 mm	3675 mm
	3600 mm	2300 mm	100 mm	4075 mm
	3900 mm	2450 mm	100 mm	4375 mm
Duplex mast ZZ	2300 mm	1600 mm	1125 mm	2775 mm
	2500 mm	1700 mm	1225 mm	2975 mm
	2900 mm	1900 mm	1425 mm	3375 mm
	3200 mm	2050 mm	1575 mm	3675 mm
	3600 mm	2250 mm	1775 mm	4075 mm
	3900 mm	2400 mm	1925 mm	4375 mm
Triplex mast DZ	4090 mm	1845 mm	1338 mm	4597 mm
	4300 mm	1915 mm	1408 mm	4807 mm
EJC 112i	Lift (h3)	Retracted mast height (h1)	Free lift (h2)	Extended mast height (h4)
Duplex mast ZT	4100 mm	2550 mm	100 mm	4575 mm
	4300 mm	2650 mm	100 mm	4775 mm
Triplex mast DZ	4700 mm	2050 mm	1564 mm	5213 mm

VDI table

Characteristic	1.1	Manufacturer (abbreviated description)		Jungheinrich		
	1.2	Manufacturer's type designation		EJC 110i (E)	EJC 110i	EJC 112i
	1.3	Drive type		electric		
	1.4	Operation		Pedestrian		
	1.5	Load capacity/load	Q kg	1000		1200
	1.6	Load centre distance	c mm	600		
	1.8	Load distance, centre of drive axle to fork	x mm	783	707	
	1.9	Wheelbase	y mm	1171	1141	
	Weights	2.1.1	Service weight (incl. battery)	kg	480	665
2.2		Axle load laden front/rear	kg	500 / 980	556 / 1109	580 / 1295
2.3		Axle load unladen front/rear	kg	350 / 130	465 / 200	475 / 200
Wheels/chassis	3.1	Tyres		Polyurethane (PU)		
	3.2	Tyre size, front		Ø 210 x 70	Ø 230 x 70	
	3.3	Tyre size, rear		Ø 75 x 70 / Ø 75 x 45	ø75x105 / ø75x80	Ø 75 x 105 / ø75x80
	3.4	Additional wheels		Ø 140 x 54		
	3.5	Wheels, number front/back (x=driven)		1x +1/2		
	3.6	Tread width, front	b10 mm	507		
	3.7	Tread width, rear	b11 mm	394	405	
Basic dimensions	4.2	Retracted mast height (h1)	h1 mm	1970	1950	
	4.3	Free lift (h2)	h2 mm	1540	100	
	4.4	Lift (h3)	h3 mm	1540	2900	
	4.5	Extended mast height (h4)	h4 mm	1970	3375	
	4.9	Height of tiller handle in drive position min./max.	h14 mm	750 / 1260		
	4.15	Height, lowered	h13 mm	90		
	4.19	Total length	l1 mm	1714	1754	
	4.20	Length including fork shank	l2 mm	564	604	
	4.21.1	total width	b1 mm	800		
	4.22	Fork dimensions	s/ e/l mm	60 x 178 x 1150		
	4.25	Width across forks	b5 mm	535	570	
	4.32	Ground clearance centre of wheelbase	m2 mm	27	24	
	Performance data	5.1	Travel speed laden/unladen	km/h	5.3 / 5.3	6 / 6
5.2		Lift speed laden/unladen	m/s	0.15 / 0.25	0.15 / 0.27	0.17 / 0.33
5.3		Lowering speed laden/unladen	m/s	0.15 / 0.15	0.34 / 0.34	0.45 / 0.37
5.8		Max. gradeability laden/unladen	%	6 / 10	6 / 14	
5.10		Service brake		generative		

Electric motor/electronics	6.1	Drive motor, performance S2 60 min	kW	1	0.9
	6.2	Lift motor, performance with S3	kW	1.2	2.2 2.8
	6.3	Battery according to DIN 43531/35/36			no
	6.4	Battery voltage/nominal capacity	V / Ah	24 / 50	24 / 100
	6.5	Battery weight	kg	24	35
	6.6.1	Energy consumption according to EN cycle	kWh/h	0.35	0.66
	6.6.2	CO2 equivalent as per EN 16796	kg/h	0.2	0.4
Other	8.1	Type of drive control			AC
	10.7	Sound pressure level according to EN12053	dB (A)	64	65
- This data sheet according to VDI guideline 2198 only states the technical values of the standard truck. Different tyres, other masts, additional equipment etc. may result in different values.					

The following applies to the EJC 110i / 112i:

The values in the table apply for the XS battery compartment, ZT2900 mast, battery 100 Ah.

- VDI no. 1.8: with DZ mast: x - 40 mm
- VDI no. 1.9: with S battery compartment: y + 50 mm.
- VDI no. 4.19: with S battery compartment: l1 + 50 mm. with DZ mast: l1 + 40 mm.
- VDI no. 4.20: with S battery compartment: l2 + 50 mm; with DZ mast: l2 + 40 mm.
- VDI no. 4.34.1: diagonal as per VDI: aisle width + 225 mm; with S battery compartment: aisle width + 48; with DZ mast: aisle width + 40 mm.
- VDI no. 4.34.2: diagonal as per VDI: aisle width + 142 mm; with S battery compartment: aisle width + 48 mm. With DZ mast: aisle width + 40 mm.
- VDI no. 4.35: with S battery compartment: Wa + 48 mm.
- VDI no. 6.2: EJC 110i: S3 5%; EJC 112i: S3 13%

The following applies for EJC 110i (E):

The values in the table apply for the MM 1540 mast.

- VDI no. 4.3: Free lift (h2) - 34 mm.
- VDI no. 4.4: Lift (h3) - 30 mm.
- VDI no. 4.5: Extended mast height (h4) + 34 mm.
- VDI no. 4.34.1: diagonal as per VDI: aisle width + 271 mm.
- VDI no. 4.34.2: diagonal as per VDI: aisle width + 161 mm.

The German production facilities in
Norderstedt, Moosburg and Landsberg
are certified as well as our Genuine Parts
Center in Kaltenkirchen.

ISO 9001
ISO 14001

Jungheinrich fork lift trucks meet
European safety requirements.



 **JUNGHEINRICH**

The Jungheinrich logo, featuring a red upward-pointing arrow above the word 'JUNGHEINRICH' in a bold, black, sans-serif font.