



Electric reach truck

ETV/ETM 210 - 216

Lift height: 4550-10700 mm / Load capacity: 1000-1600 kg



ETV/ETM 210 - 216

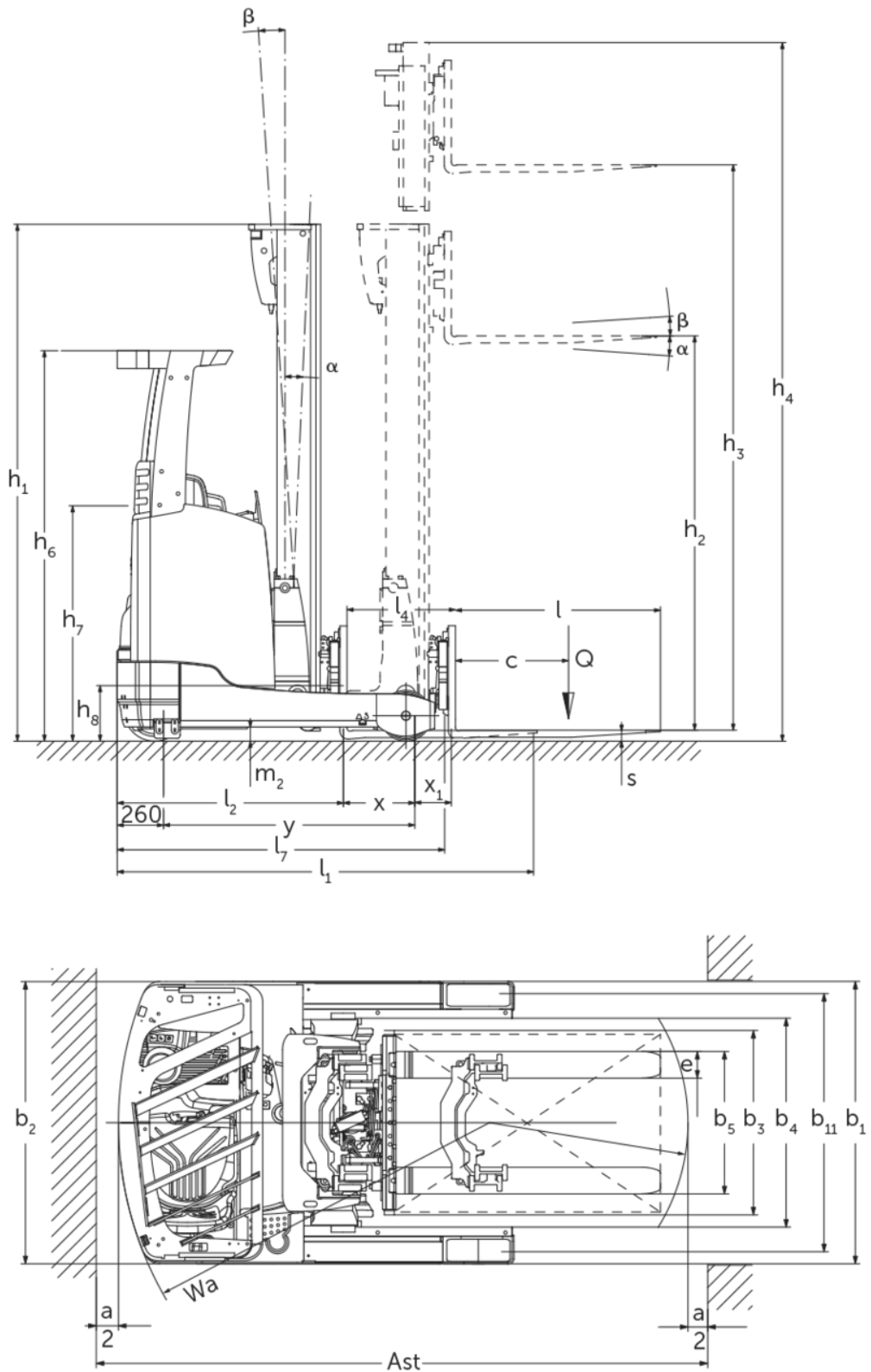

ETV/ETM 210 - 216

	Lift (h3)	Retracted mast height (h1)	Free lift (h2)	Extended mast height (h4)	Forward/backward tilt of mast	Forward/backward tilt of fork carriage
Fork tilt / Triplex mast DZ / cold-formed	5000 mm	2200 mm	1546 mm	5654 mm		2 / 5 °
	5300 mm	2300 mm	1646 mm	5954 mm		2 / 5 °
	5600 mm	2400 mm	1746 mm	6254 mm		2 / 5 °
	5900 mm	2500 mm	1846 mm	6554 mm		2 / 5 °
	6200 mm	2600 mm	1946 mm	6854 mm		2 / 5 °
	6500 mm	2700 mm	2046 mm	7154 mm		2 / 5 °
	6800 mm	2800 mm	2146 mm	7454 mm		2 / 5 °
	7100 mm	2900 mm	2246 mm	7754 mm		2 / 5 °
	7400 mm	3000 mm	2346 mm	8054 mm		2 / 5 °
	7700 mm	3100 mm	2446 mm	8354 mm		2 / 5 °
	8000 mm	3200 mm	2546 mm	8654 mm		2 / 5 °
	8300 mm	3300 mm	2646 mm	8954 mm		2 / 5 °
	8420 mm	3340 mm	2686 mm	9074 mm		2 / 5 °
	8720 mm	3440 mm	2786 mm	9374 mm		2 / 5 °
	9020 mm	3540 mm	2886 mm	9674 mm		2 / 5 °
	9410 mm	3670 mm	3016 mm	10064 mm		2 / 5 °
	9920 mm	3840 mm	3186 mm	10574 mm		2 / 5 °
	10250 mm	3950 mm	3296 mm	10904 mm		2 / 5 °
10520 mm	4040 mm	3386 mm	11174 mm		2 / 5 °	
10700 mm	4100 mm	3446 mm	11354 mm		2 / 5 °	
...	Lift (h3)	Retracted mast height (h1)	Free lift (h2)	Extended mast height (h4)	Forward/backward tilt of mast	Forward/backward tilt of fork carriage
Mast tilt / Triplex mast DZ / cold-formed	6500 mm	2700 mm	2046 mm	7154 mm	0.5 / 2 °	
	6800 mm	2800 mm	2146 mm	7454 mm	0.5 / 2 °	
	7100 mm	2900 mm	2246 mm	7754 mm	0.5 / 2 °	
	7310 mm	2970 mm	2316 mm	7964 mm	0.5 / 1 °	
	7400 mm	3000 mm	2346 mm	8054 mm	0.5 / 1 °	
	7700 mm	3100 mm	2446 mm	8354 mm	0.5 / 1 °	
	8000 mm	3200 mm	2546 mm	8654 mm	0.5 / 1 °	

	8300 mm	3300 mm	2646 mm	8954 mm	0.5 / 1 °	
	8420 mm	3340 mm	2686 mm	9074 mm	0.5 / 1 °	
	8720 mm	3440 mm	2786 mm	9374 mm	0.5 / 1 °	
	9020 mm	3540 mm	2886 mm	9674 mm	0.5 / 1 °	
ETV 210 , ETV 212, ...	Lift (h3)	Retracted mast height (h1)	Free lift (h2)	Extended mast height (h4)	Forward/backward tilt of mast	Forward/backward tilt of fork carriage
	4550 mm	2050 mm	1396 mm	5204 mm	1 / 5 °	
	5000 mm	2200 mm	1546 mm	5654 mm	1 / 5 °	
	5240 mm	2280 mm	1626 mm	5894 mm	1 / 5 °	
	5300 mm	2300 mm	1646 mm	5954 mm	1 / 5 °	
	5450 mm	2350 mm	1696 mm	6104 mm	1 / 3 °	
	5600 mm	2400 mm	1746 mm	6254 mm	1 / 3 °	
	5720 mm	2440 mm	1786 mm	6374 mm	1 / 3 °	
	5900 mm	2500 mm	1846 mm	6554 mm	1 / 3 °	
	6200 mm	2600 mm	1946 mm	6854 mm	1 / 3 °	
	6500 mm	2700 mm	2046 mm	7154 mm	0.5 / 2 °	
	6800 mm	2800 mm	2146 mm	7454 mm	0.5 / 2 °	
	7100 mm	2900 mm	2246 mm	7754 mm	0.5 / 2 °	
	7310 mm	2970 mm	2316 mm	7964 mm	0.5 / 1 °	
	7400 mm	3000 mm	2346 mm	8054 mm	0.5 / 1 °	
Mast tilt / Triplex mast DZ / hot-rolled						

VDI table

Characteristic	1.1	Manufacturer (abbreviated description)		Jungheinrich					
	1.2	Manufacturer's type designation		ETV 210	ETV 212	-			
	1.3	Drive		Electric					
	1.4	Operation		Sideways-seated					
	1.5	Load capacity/load	Q kg	1000	1200	1400	1600		
	1.6	Load centre distance	c mm	600					
	1.8	Load distance, centre of drive axle to fork	x mm	315	400	353	423	403	413
	1.8.1	Load distance, centre of drive axle to fork, mast extended	mm	170		205			
	1.9	Wheelbase	y mm	1300	1385	1410		1460	
Weights	2.1.1	Service weight (incl. battery)	kg	2560	2580	2975	3000	3110	3136
	2.3	Axle load unladen front/rear	kg	1587 / 973	1587 / 993	1785 / 1190	1830 / 1170	1835 / 1275	1882 / 1254
	2.4	Axle load fork forward laden front/rear	kg	634 / 2926	516 / 3264	481 / 3894	572 / 3828	518 / 4192	521 / 4215
	2.5	Axle load fork back laden front/rear	kg	1282 / 2278	1361 / 2419	1531 / 2844	1628 / 2772	1649 / 3061	1658 / 3078
Wheels/suspension system	3.1	Tyres		Polyurethane (PU)					
	3.2	Tyre size, front		Ø 343 x 114					
	3.3	Tyre size, rear		Ø 230 x 85		Ø 285 x 100			
	3.5	Wheels, number front/back (x=driven)		1x / 2					
	3.7	Tread width, rear	b11 mm	993	986	1136	986	1136	
Basic dimensions	4.1	Forward/backward tilt of mast	a/β °	1 / 3					
	4.2	Retracted mast height (h1)	h1 mm	2300	2400				
	4.3	Free lift (h2)	h2 mm	1646	1746				
	4.4	Lift (h3)	h3 mm	5300	5600				
	4.5	Extended mast height (h4)	h4 mm	5954	6254				
	4.7	Height of overhead guard (cab)	h6 mm	2190					
	4.8	Seat height/stand height	h7 mm	1057					
	4.10	Height of support arms	h8 mm	265	285				
	4.19	total length	l1 mm	2346	2418	2348	2418	2408	
	4.20	Length including fork shank	l2 mm	1196	1268	1198	1268	1258	
	4.21.1	total width	b1 mm	1120		1270	1120	1270	
	4.21.2	total width	b2 mm	1120		1270	1120	1270	
	4.22	Fork dimensions	s/ e/l mm	40 x 80 x 1150		40 x 120 x 1150			
	4.23	Fork carriage connection class		2B					
	4.24	Fork carriage width	b3 mm	800	830				
	4.25	Width across forks	b5 mm	296	335				
	4.25.1	Width across forks (min./max.)	b5 mm	296 / 705	335 / 560	335 / 705	335 / 560	335 / 705	
	4.26	Width between support arms/loading areas	b4 mm	900	780	940	780	940	
	4.28	Reach distance	mm	485	570	558	628	608	618
	4.32	Ground clearance centre of wheelbase	m2 mm	80					
4.34.1	Aisle width (pallet 1000x1200 sideways)	Ast mm	2626	2644	2702	2652	2716	2709	
4.34.2	Aisle width (pallet 800x1200 length)	Ast mm	2686	2689	2757	2694	2762	2753	

	4.35	Turning radius	Wa mm	1515	1595	1620	1670
	4.37	Length over the support arms	L7 mm	1640	1725	1780	1830
Performance data	5.1	Travel speed laden/unladen (Efficiency drivePLUS)	km/h	11 / 11 - / -		11 / 11 14 / 14	
	5.2	Lift speed laden/unladen (Efficiency liftPLUS)	m/s	0.48 / 0.7 - / -	0.43 / 0.7 - / -	0.38 / 0.7 0.51 / 0.7	0.35 / 0.7 0.48 / 0.7
	5.3	Lowering speed laden/unladen (Efficiency liftPLUS)	m/s	0.5 / 0.5 - / -		0.55 / 0.55 0.55 / 0.55	
	5.4	Reach speed laden/unladen (Efficiency liftPLUS)	m/s	0.2 / 0.2 - / -		0.18 / 0.18 0.22 / 0.22	
	5.7	Gradeability laden/unladen (Efficiency drivePLUS)	%	7 / 10 - / -		9 / 13 9 / 13 8 / 12 8 / 12	
	5.8	Max. gradeability laden/unladen (Efficiency drivePLUS)	%	10 / 15 - / -		10 / 15 10 / 15	
	5.9	Acceleration time laden/unladen (Efficiency drivePLUS)	s	4.8 / 4.3 - / -	4.9 / 4.5 - / -	5.3 / 5 4.7 / 4.3	5.4 / 5 4.8 / 4.3
	5.10	Service brake		electric			
E-motor/Electronics	6.1	Drive motor, performance S2 60 min (Efficiency drivePLUS)	kW	6 -		6 8.5	
	6.2	Lift motor, performance with S3 (Efficiency liftPLUS)	kW	13.3 -		13.3 15.5	
	6.3	Battery according to DIN 43531/35/36		DIN 43531 B		DIN 43531 C	DIN 43531 B DIN 43531 C
	6.4	Battery voltage/nominal capacity	V / Ah	48 / 280		48 / 465	
	6.5	Battery weight	kg	556		750	
	6.6.1	Energy consumption according to EN cycle (Efficiency PLUS)	kWh/h	2.81 -	3.05 -	3.16 3.21	3.19 3.23
	6.6.2	CO2 equivalent as per EN 16796 (Efficiency PLUS)	kg/h	1.5 -	1.7 -	1.7 1.7	
	6.7	Throughput (Efficiency PLUS)	t/h	38.63 -	46.65 -	52.34 60.8	58.42 68.74
	6.8	Turnover efficiency according to VDI 2198 (Efficiency PLUS)	t/kWh	13.4 -	15.2 -	17 15	18.1 16.7
	6.8.1	Energy consumption with max. throughput (Efficiency PLUS)	kWh/h	2.89 -	3.06 -	3.08 4.04	3.22 4.11
Other	8.1	Type of drive control		Impulse / Mosfet AC		Mosfet/AC	
	10.1	Operating pressure for attachment	bar	150			
	10.2	Oil flow for attachments	l/min	20			
	10.7	Sound pressure level according to EN12053	dB (A)	68			

- This data sheet according to VDI guideline 2198 only states the technical values of the standard truck. Different tyres, other masts, additional equipment etc. may result in different values.

- VDI no. 1.8: battery size and mast type affect load distance x
- VDI no. 2.1.1: the battery size and mast version affect service weight and axle loads
- VDI no. 2.3: the battery size and mast version affect service weight and axle loads
- VDI no. 2.4: the battery size and mast version affect service weight and axle loads
- VDI no. 2.5: the battery size and mast version affect service weight and axle loads
- VDI no. 4.1: the mast version determines the tilt values
- VDI no. 4.10: the height of the support arms is increased by 30 mm with a load wheel cover
- VDI no. 4.19: the battery size, mast type and fork length affect the overall length l1
- VDI no. 4.20: the battery size and mast type affect the length including fork shank l2
- VDI no. 4.28: battery size and mast type affect the reach distance l4
- VDI no. 4.34.1: the battery size and mast type affect the aisle widths
- VDI no. 4.34.2: the battery size and mast type affect the aisle widths
- VDI no. 6.6.1: PLUS refers to the drive&liftPLUS performance package
- VDI no. 6.6.2: PLUS refers to the drive&liftPLUS performance package
- VDI no. 6.7: PLUS refers to the drive&liftPLUS performance package
- VDI no. 6.8.1: PLUS refers to the drive&liftPLUS performance package

The German production facilities in
Norderstedt, Moosburg and Landsberg
are certified as well as our Genuine Parts
Center in Kaltenkirchen.

ISO 9001
ISO 14001

Jungheinrich fork lift trucks meet
European safety requirements.



 **JUNGHEINRICH**

The Jungheinrich logo, featuring a red upward-pointing arrow above the word 'JUNGHEINRICH' in a bold, black, sans-serif font.