



# Electric three-wheel counterbalance forklift truck

**EFG 112**

Lift height: 2900-7000 mm / Load capacity: 1200 kg

**LION**  
technology

**JUNGHEINRICH**

# EFG 112

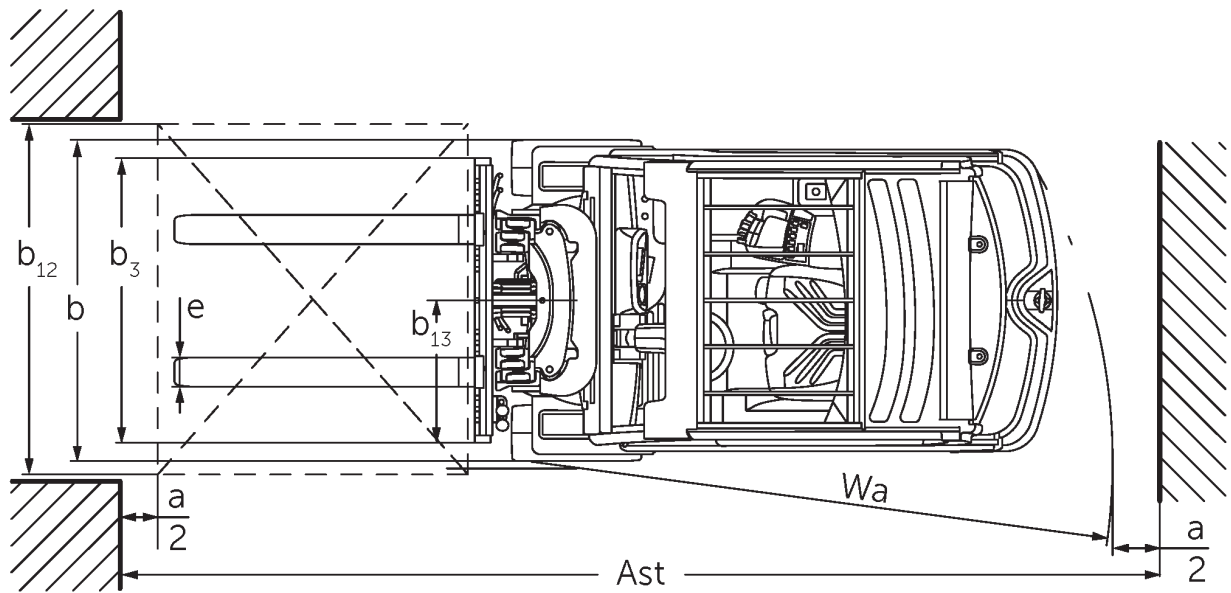
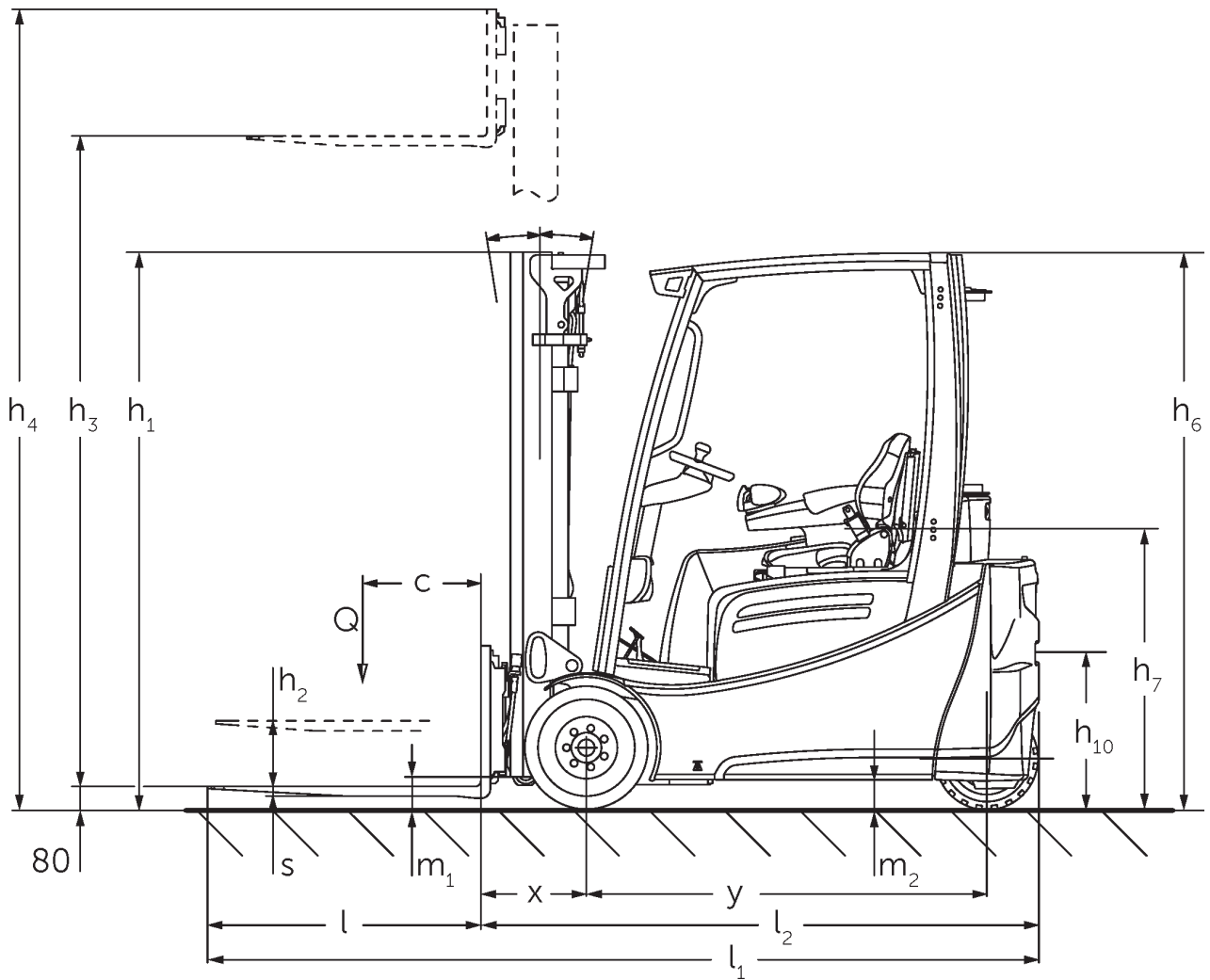

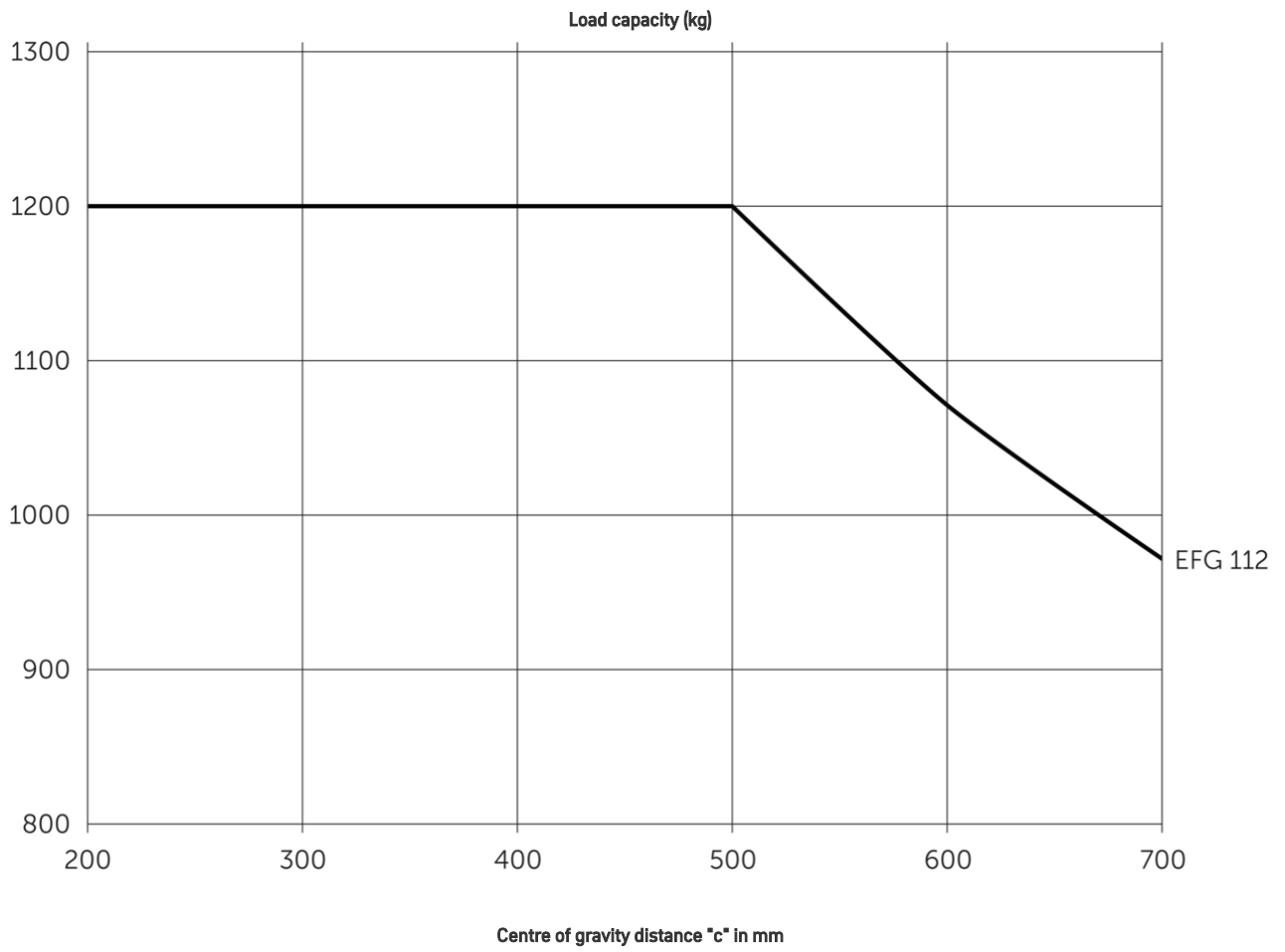

# EFG 112

EFG 112	Lift (h3)	Retracted mast height (h1)	Free lift (h2)	Extended mast height (h4)	Forward/backward tilt of mast
Duplex mast ZT	3000 mm	2060 mm	150 mm	3590 mm	7 / 6 °
	3100 mm	2110 mm	150 mm	3690 mm	7 / 6 °
	3300 mm	2210 mm	150 mm	3890 mm	7 / 7 °
	3500 mm	2310 mm	150 mm	4090 mm	7 / 7 °
	3700 mm	2410 mm	150 mm	4290 mm	7 / 7 °
	4000 mm	2560 mm	150 mm	4590 mm	7 / 7 °
	4500 mm	2810 mm	150 mm	5090 mm	7 / 7 °
Duplex mast ZZ	2900 mm	1965 mm	1375 mm	3490 mm	7 / 6 °
	3100 mm	2065 mm	1475 mm	3690 mm	7 / 6 °
	3180 mm	2105 mm	1515 mm	3770 mm	7 / 7 °
	3300 mm	2165 mm	1575 mm	3890 mm	7 / 7 °
	3500 mm	2265 mm	1675 mm	4090 mm	7 / 7 °
	3700 mm	2365 mm	1775 mm	4290 mm	7 / 7 °
	4000 mm	2515 mm	1925 mm	4590 mm	7 / 7 °
Triplex mast DZ	4250 mm	1975 mm	1385 mm	4840 mm	7 / 4 °
	4400 mm	2025 mm	1435 mm	4990 mm	7 / 4 °
	4640 mm	2105 mm	1515 mm	5230 mm	7 / 5 °
	4700 mm	2125 mm	1535 mm	5290 mm	7 / 5 °
	4800 mm	2165 mm	1575 mm	5390 mm	7 / 5 °
	5000 mm	2235 mm	1645 mm	5590 mm	7 / 5 °
	5500 mm	2415 mm	1825 mm	6090 mm	7 / 5 °
	6000 mm	2585 mm	1995 mm	6590 mm	7 / 5 °
	6500 mm	2765 mm	2175 mm	7090 mm	7 / 5 °
7000 mm	2935 mm	2345 mm	7590 mm	7 / 5 °	

## VDI table

Characteristic	1.1	Manufacturer (abbreviated description)		Jungheinrich	
	1.2	Manufacturer's type designation		EFG 112	
	1.3	Drive type		electric	
	1.4	Operation		Seat	
	1.5	Load capacity/load	Q	kg	1200
	1.6	Load centre distance	c	mm	500
	1.8	Load distance, centre of drive axle to fork	x	mm	344
	1.9	Wheelbase	y	mm	1249
Weights	2.1.1	Service weight (incl. battery)		kg	2622
	2.2	Axle load laden front/rear		kg	3318 / 504
	2.3	Axle load unladen front/rear		kg	1307 / 1315
Wheels/chassis	3.1	Tyres			Super-elastic (SE)
	3.2	Tyre size, front			18 x 7-8
	3.3	Tyre size, rear			140 / 55-9
	3.5	Wheels, number front/back (x=driven)			2x/2
	3.6	Tread width, front	b10	mm	904
	3.7	Tread width, rear	b11	mm	176
	Basic dimensions	4.1	Forward/backward tilt of mast	a/β	°
4.2		Retracted mast height (h1)	h1	mm	2060
4.3		Free lift (h2)	h2	mm	150
4.4		Lift (h3)	h3	mm	3000
4.5		Extended mast height (h4)	h4	mm	3590
4.7		Height of overhead guard (cab)	h6	mm	2040
4.8		Seat height/stand height	h7	mm	920
4.12		Coupling height	h10	mm	560
4.19		Total length	l1	mm	2933
4.20		Length including fork shank	l2	mm	1783
4.21.1		total width	b1	mm	1060
4.22		Fork dimensions	s/e/l	mm	40 x 80 x 1150
4.23		Fork carriage connection class			2A
4.24		Fork carriage width	b3	mm	980
4.31		Ground clearance laden under mast	m1	mm	97
4.32		Ground clearance centre of wheelbase	m2	mm	100
4.34.1		Aisle width (pallet 1000×1200 sideways)	Ast	mm	3112
4.34.2		Aisle width (pallet 800×1200 length)	Ast	mm	3235
4.35		Turning radius	Wa	mm	1440
4.36		Smallest pivot point distance	b13	mm	0
Performance data	5.1	Travel speed laden/unladen		km/h	12 / 12
	5.2	Lift speed laden/unladen		m/s	0.3 / 0.48
	5.3	Lowering speed laden/unladen		m/s	0.55 / 0.55
	5.5	Drawbar pull laden/unladen		N	2100 / 2300
	5.6	Max. drawbar pull laden/unladen		N	9500 / 8000
	5.7	Gradeability laden/unladen		%	7.5 / 11
	5.8	Max. gradeability laden/unladen		%	25 / 28
	5.9	Acceleration time laden/unladen		s	6.1 / 5.7

	5.10	Service brake		Friction brake (mechanically operated)
Electric motor/electronics	6.1	Drive motor, performance S2 60 min	kW	2.8
	6.1.1	2. Drive motor, performance S2 60 min	kW	2.8
	6.2	Lift motor, performance with S3	kW	8.2
	6.3	Battery according to DIN 43531/35/36		DIN 43531 A
	6.4	Battery voltage/nominal capacity	V / Ah	48 / 500
	6.5	Battery weight	kg	715
	6.6.1	Energy consumption according to EN cycle	kWh/h	3.4
	6.6.2	CO2 equivalent as per EN 16796	kg/h	1.8
	6.7	Throughput	t/h	80
	6.8	Turnover efficiency according to VDI 2198	t/kWh	21.1
Other	8.1	Type of drive control		Impulse/AC
	10.1	Operating pressure for attachment	bar	230
	10.2	Oil flow for attachments	l/min	27
	10.7	Sound pressure level according to EN12053	dB (A)	65
	10.8	Trailer coupling, model/type DIN		DIN 15170 H
- This data sheet according to VDI guideline 2198 only states the technical values of the standard truck. Different tyres, other masts, additional equipment etc. may result in different values.				

The German production facilities in  
Norderstedt, Moosburg and Landsberg are  
certified as well as our Genuine Parts  
Center in Kaltenkirchen.

ISO 9001  
ISO 14001

Jungheinrich fork lift trucks meet European  
safety requirements.



 **JUNGHEINRICH**

The Jungheinrich logo, featuring a red upward-pointing arrow above the word 'JUNGHEINRICH' in a bold, black, sans-serif font.