



Electric four wheel counterbalance forklift truck

EFG 316-320

Lift height: 2020-7000 mm / Load capacity: 1600-2000 kg



EFG 316-320

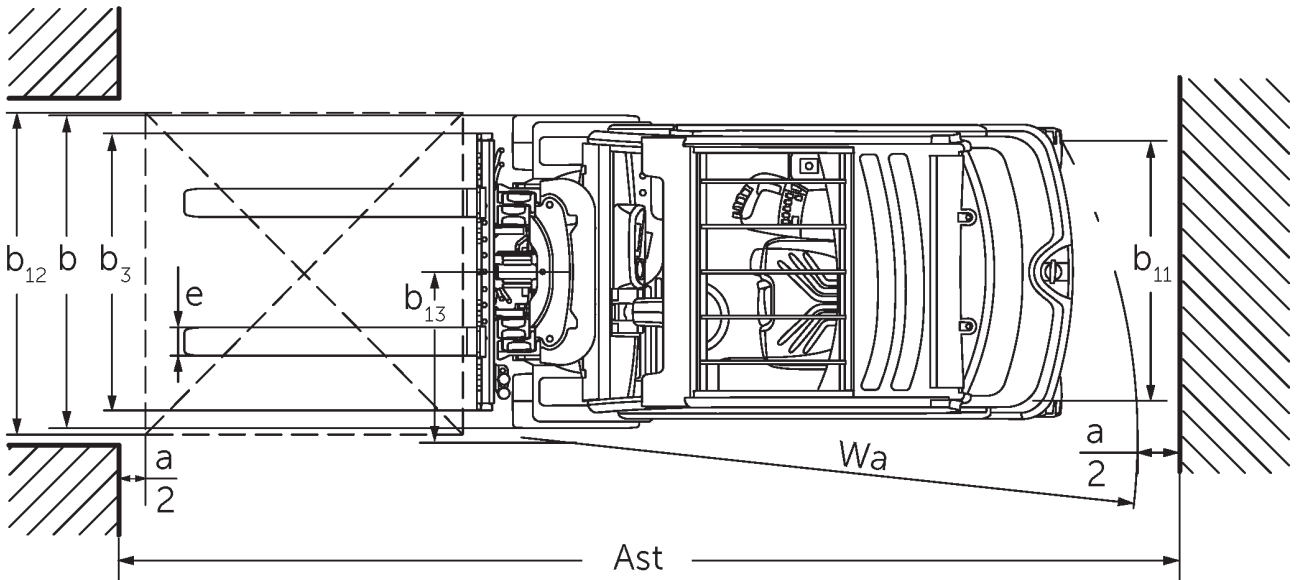
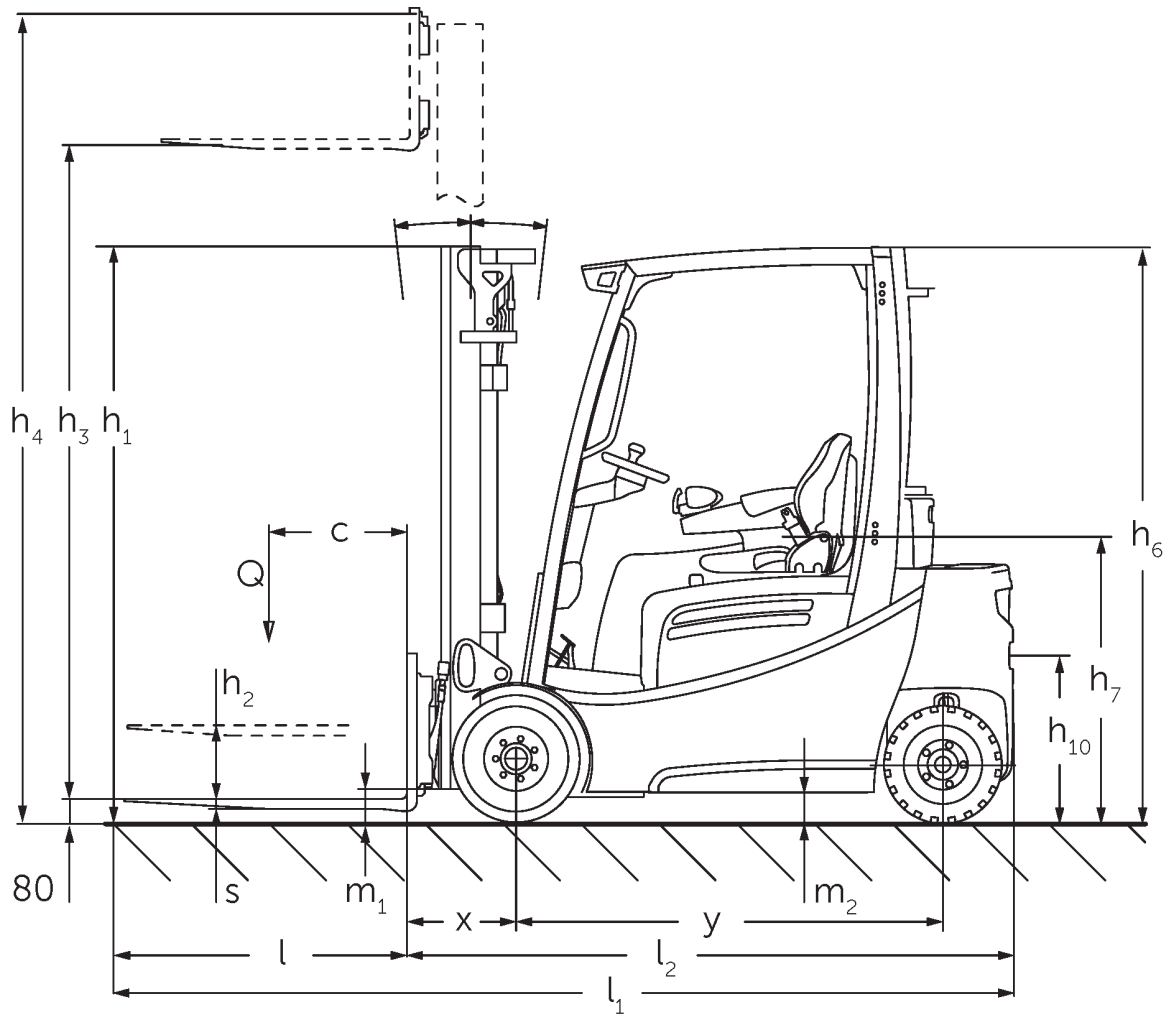

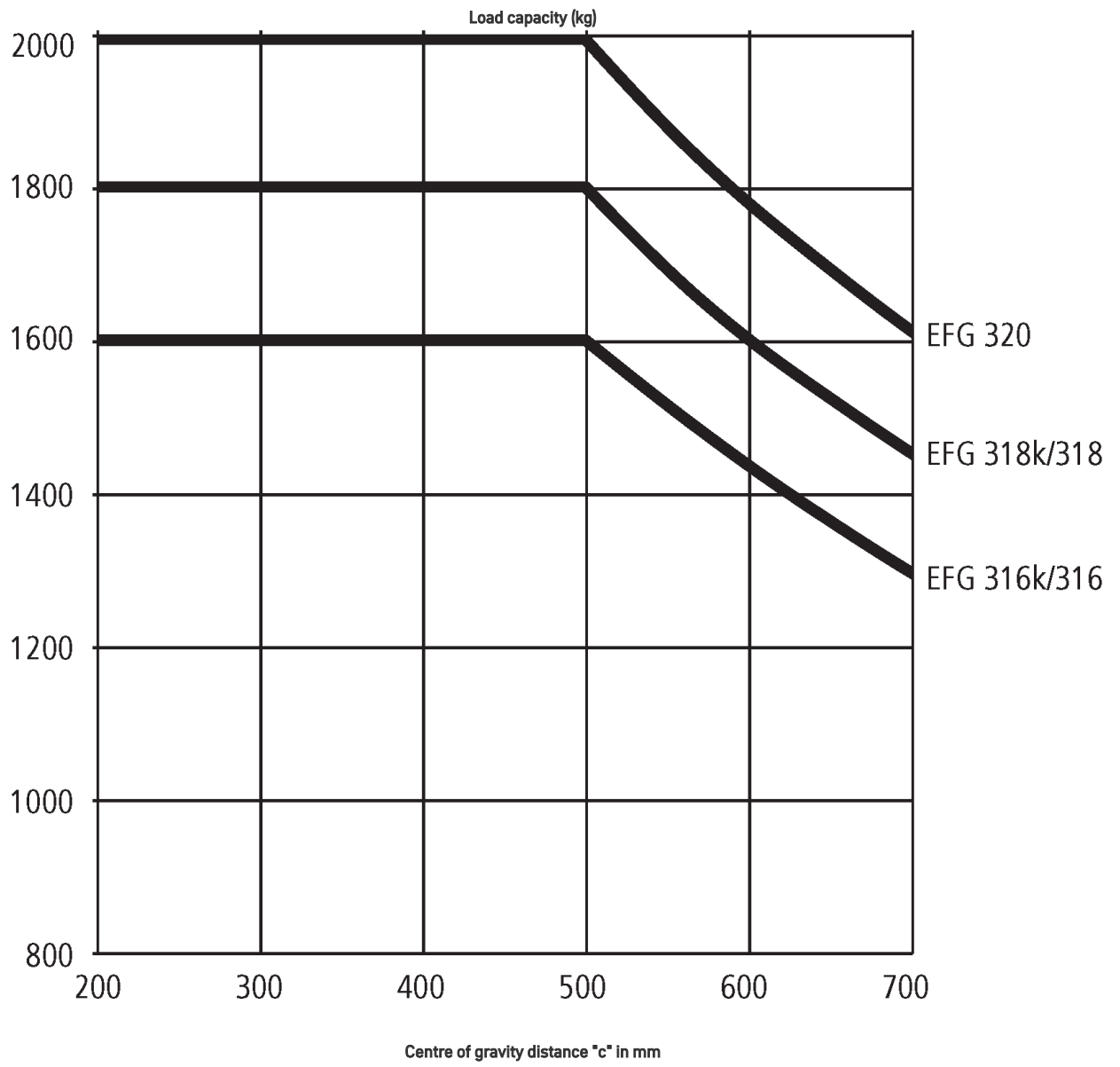

EFG 316-320

EFG 316k, EFG 316	Lift (h3)	Retracted mast height (h1)	Free lift (h2)	Extended mast height (h4)	Forward/backward tilt of mast
Duplex mast ZT	3000 mm	2060 mm	150 mm	3590 mm	7 / 6 °
	3100 mm	2110 mm	150 mm	3690 mm	7 / 6 °
	3300 mm	2210 mm	150 mm	3890 mm	7 / 7 °
	3500 mm	2310 mm	150 mm	4090 mm	7 / 7 °
	3700 mm	2410 mm	150 mm	4290 mm	7 / 7 °
	4000 mm	2560 mm	150 mm	4590 mm	7 / 7 °
	4500 mm	2810 mm	150 mm	5090 mm	7 / 7 °
Duplex mast ZZ	2900 mm	1965 mm	1375 mm	3490 mm	7 / 6 °
	3100 mm	2065 mm	1475 mm	3690 mm	7 / 6 °
	3180 mm	2105 mm	1515 mm	3770 mm	7 / 7 °
	3300 mm	2165 mm	1575 mm	3890 mm	7 / 7 °
	3500 mm	2265 mm	1675 mm	4090 mm	7 / 7 °
	3700 mm	2365 mm	1775 mm	4290 mm	7 / 7 °
	4000 mm	2515 mm	1925 mm	4590 mm	7 / 7 °
Triplex mast DZ	4250 mm	1975 mm	1385 mm	4840 mm	7 / 4 °
	4400 mm	2025 mm	1435 mm	4990 mm	7 / 4 °
	4640 mm	2105 mm	1515 mm	5230 mm	7 / 5 °
	4700 mm	2125 mm	1535 mm	5290 mm	7 / 5 °
	4800 mm	2165 mm	1575 mm	5390 mm	7 / 5 °
	5000 mm	2235 mm	1645 mm	5590 mm	7 / 5 °
	5500 mm	2415 mm	1825 mm	6090 mm	7 / 5 °
	6000 mm	2585 mm	1995 mm	6590 mm	7 / 5 °
	6500 mm	2765 mm	2175 mm	7090 mm	7 / 5 °
7000 mm	2935 mm	2345 mm	7590 mm	7 / 5 °	
EFG 318k, EFG 318, EFG 320	Lift (h3)	Retracted mast height (h1)	Free lift (h2)	Extended mast height (h4)	Forward/backward tilt of mast

Duplex mast ZT	2020 mm	1577 mm	150 mm	2632 mm	7 / 5 °
	3000 mm	2067 mm	150 mm	3612 mm	7 / 6 °
	3100 mm	2117 mm	150 mm	3712 mm	7 / 6 °
	3300 mm	2217 mm	150 mm	3912 mm	7 / 7 °
	3500 mm	2317 mm	150 mm	4112 mm	7 / 7 °
	3700 mm	2417 mm	150 mm	4312 mm	7 / 7 °
	4000 mm	2567 mm	150 mm	4612 mm	7 / 7 °
	4500 mm	2817 mm	150 mm	5112 mm	7 / 7 °
Duplex mast ZZ	2900 mm	1972 mm	1330 mm	3542 mm	7 / 6 °
	3100 mm	2072 mm	1430 mm	3742 mm	7 / 6 °
	3180 mm	2112 mm	1470 mm	3822 mm	7 / 7 °
	3300 mm	2172 mm	1530 mm	3942 mm	7 / 7 °
	3500 mm	2272 mm	1630 mm	4142 mm	7 / 7 °
	3700 mm	2372 mm	1730 mm	4342 mm	7 / 7 °
	4000 mm	2522 mm	1880 mm	4642 mm	7 / 7 °
Triplex mast DZ	4250 mm	1982 mm	1340 mm	4892 mm	7 / 6 °
	4400 mm	2032 mm	1390 mm	5042 mm	7 / 6 °
	4640 mm	2112 mm	1470 mm	5282 mm	7 / 5 °
	4700 mm	2132 mm	1490 mm	5342 mm	7 / 5 °
	4800 mm	2172 mm	1530 mm	5442 mm	7 / 5 °
	5000 mm	2242 mm	1600 mm	5642 mm	7 / 5 °
	5500 mm	2422 mm	1780 mm	6142 mm	7 / 5 °
	6000 mm	2592 mm	1950 mm	6642 mm	7 / 5 °
	6500 mm	2772 mm	2130 mm	7142 mm	7 / 5 °
	7000 mm	2942 mm	2300 mm	7642 mm	7 / 5 °

VDI table

		Jungheinrich						
Characteristic	1.1	Manufacturer (abbreviated description)						
	1.2	Manufacturer's type designation	EFG 316k	EFG 316	EFG 318k	EFG 318	EFG 320	
	1.3	Drive type	electric					
	1.4	Operation	Seat					
	1.5	Load capacity/load	Q kg	1600	1800	2000		
	1.6	Load centre distance	c mm	500				
	1.8	Load distance, centre of drive axle to fork	x mm	344	364			
	1.9	Wheelbase	y mm	1400	1508	1400	1508	
	Weights	2.1.1	Service weight (incl. battery)	kg	2994	2965	3159	3130
2.2		Axle load laden front/rear	kg	3995 / 599	4033 / 532	4413 / 546	4437 / 493	4753 / 537
2.3		Axle load unladen front/rear	kg	1362 / 1632	1474 / 1491	1399 / 1760	1512 / 1618	1503 / 1787
Wheels/chassis	3.1	Tyres	Super-elastic (SE)					
	3.2	Tyre size, front	18 x 7-8		200 / 50-10			
	3.3	Tyre size, rear	16 x 6-8					
	3.5	Wheels, number front/back (x=driven)	2x/2					
	3.6	Tread width, front	b10 mm	904	914			
	3.7	Tread width, rear	b11 mm	830				
	Basic dimensions	4.1	Forward/backward tilt of mast	a/β °	7 / 6			
4.2		Retracted mast height (h1)	h1 mm	2060	2067			
4.3		Free lift (h2)	h2 mm	150				
4.4		Lift (h3)	h3 mm	3000				
4.5		Extended mast height (h4)	h4 mm	3590	3612			
4.7		Height of overhead guard (cab)	h6 mm	2040				
4.8		Seat height/stand height	h7 mm	920				
4.12		Coupling height	h10 mm	410				
4.12.1		2. Coupling height	mm	580				
4.19		Total length	l1 mm	3144	3252	3164	3272	
4.20		Length including fork shank	l2 mm	1994	2102	2014	2122	
4.21.1		total width	b1 mm	1060	1120			
4.22		Fork dimensions	s/e/l mm	40 x 80 x 1150				40 x 100 x 1150
4.23		Fork carriage connection class		2A				
4.24		Fork carriage width	b3 mm	980				
4.31		Ground clearance laden under mast	m1 mm	97	105			
4.32		Ground clearance centre of wheelbase	m2 mm	100				
4.34.1		Aisle width (pallet 1000x1200 sideways)	Ast mm	3407	3530	3427	3550	
4.34.2		Aisle width (pallet 800x1200 length)	Ast mm	3603	3729	3623	3749	
4.35		Turning radius	Wa mm	1859	1985	1859	1985	
4.36	Smallest pivot point distance	b13 mm	498	562	498	562		

Performance data	5.1	Travel speed laden/unladen	km/h	17 / 17				
	5.2	Lift speed laden/unladen	m/s	0.51 / 0.74		0.46 / 0.74		0.4 / 0.63
	5.3	Lowering speed laden/unladen	m/s	0.55 / 0.55				
	5.5	Drawbar pull laden/unladen	N	2150 / 2450	2100 / 2450	2000 / 2300		
	5.6	Max. drawbar pull laden/unladen	N	13000 / 11900		12500 / 12200	12500 / 12500	12300 / 12000
	5.7	Gradeability laden/unladen	%	7.3 / 12.3	7 / 11.5	6.2 / 10.7	5.9 / 10.5	5.7 / 10.4
	5.8	Max. gradeability laden/unladen	%	27 / 30	27 / 33	25 / 29	25 / 32	24 / 31
	5.9	Acceleration time laden/unladen	s	5.7 / 5.2		5.8 / 5.2		5.9 / 5.5
	5.10	Service brake		Friction brake (mechanically operated)				
	Electric motor/electronics	6.1	Drive motor, performance S2 60 min	kW	4.5			
6.1.1		2. Drive motor, performance S2 60 min	kW	4.5				
6.2		Lift motor, performance with S3	kW	11.5				
6.3		Battery according to DIN 43531/35/36		DIN 43531 A				
6.4		Battery voltage/nominal capacity	V / Ah	48 / 625	48 / 750	48 / 625	48 / 750	
6.5		Battery weight	kg	855	1025	855	1025	
6.6.1		Energy consumption according to EN cycle	kWh/h	3.9		4.1		4.5
6.6.2		CO2 equivalent according to EN ISO 23308	kg/h0	2.1		2.2		2.4
6.7		Throughput	t/h	112		124		138
6.8	Turnover efficiency according to VDI 2198	t/kWh	22.9		23		25.1	
Other	8.1	Type of drive control		Impulse/AC				
	10.1	Operating pressure for attachment	bar	230				
	10.2	Oil flow for attachments	l/min	27				
	10.7	Sound pressure level according to EN12053	dB (A)	67				
	10.8	Trailer coupling, model/type DIN		DIN 15170 H				
- This data sheet according to VDI guideline 2198 only states the technical values of the standard truck. Different tyres, other masts, additional equipment etc. may result in different values.								

- 6.6.1: 60 working cycles / h

The German production facilities in
Norderstedt, Moosburg and Landsberg are
certified as well as our Genuine Parts
Center in Kaltenkirchen.

ISO 9001
ISO 14001

Jungheinrich fork lift trucks meet European
safety requirements.



 **JUNGHEINRICH**

The logo features a red arrow pointing upwards, positioned to the left of the word 'JUNGHEINRICH' which is written in a bold, black, sans-serif font.