



Electric pedestrian stacker

EJC 212-230

Lift height: 2500-6000 mm / Load capacity: 1200-3000 kg



EJC 212-230

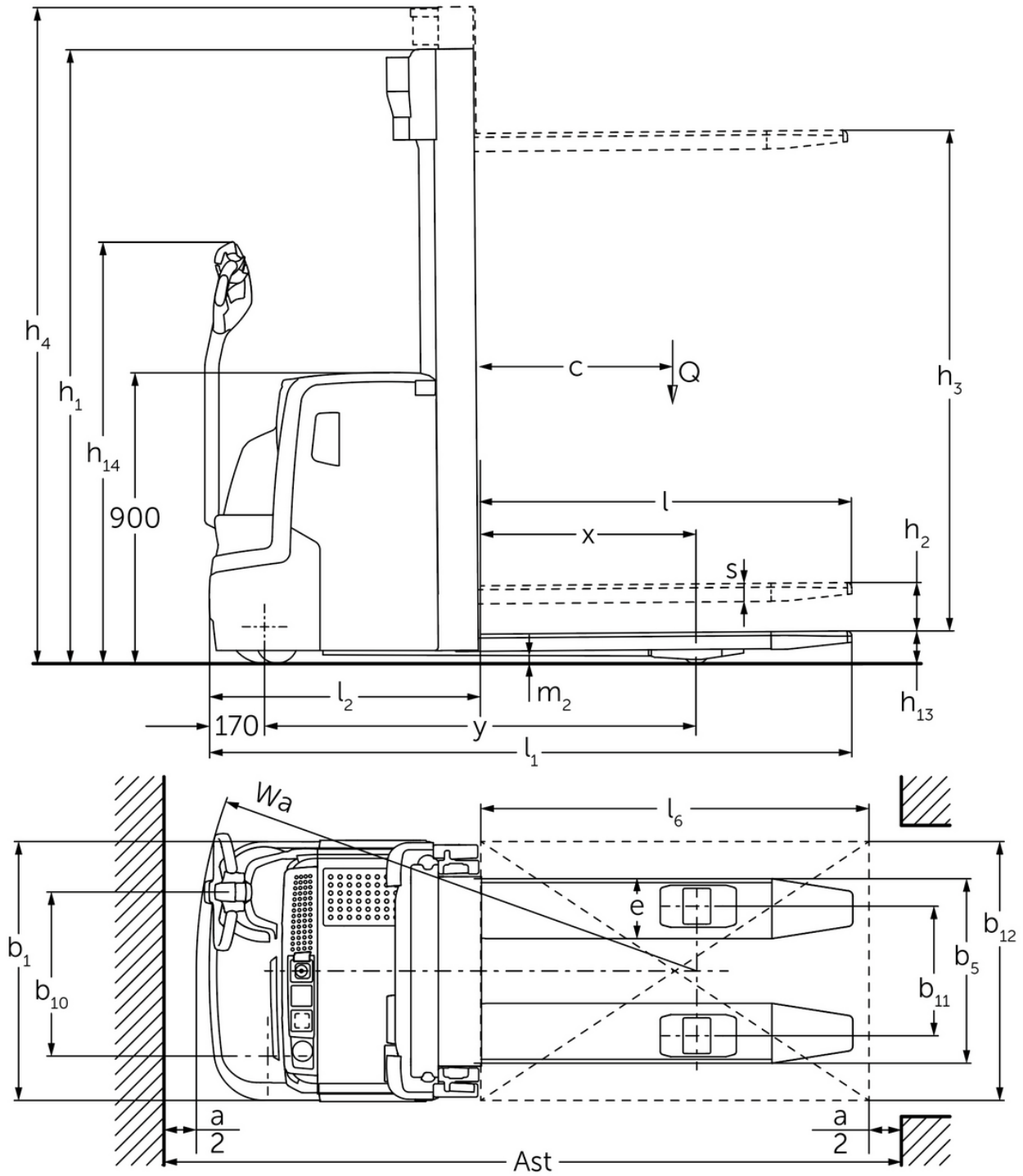

EJC 212-230

EJC 212		Lift (h3)	Retracted mast height (h1)	Free lift (h2)	Extended mast height (h4)
Duplex mast ZT		2500 mm	1750 mm	100 mm	2975 mm
		2700 mm	1850 mm	100 mm	3175 mm
		2900 mm	1950 mm	100 mm	3375 mm
		3200 mm	2100 mm	100 mm	3675 mm
		3600 mm	2300 mm	100 mm	4075 mm
		4100 mm	2550 mm	100 mm	4575 mm
		4300 mm	2650 mm	100 mm	4775 mm
Duplex mast ZZ		2500 mm	1700 mm	1225 mm	2975 mm
		2900 mm	1900 mm	1425 mm	3375 mm
		3200 mm	2050 mm	1575 mm	3675 mm
		3600 mm	2250 mm	1775 mm	4075 mm
		4100 mm	2500 mm	2025 mm	4575 mm
		4300 mm	2600 mm	2125 mm	4775 mm
Triplex mast DZ		4090 mm	1845 mm	1338 mm	4597 mm
		4300 mm	1915 mm	1408 mm	4807 mm
		4700 mm	2050 mm	1543 mm	5207 mm
EJC 214		Lift (h3)	Retracted mast height (h1)	Free lift (h2)	Extended mast height (h4)
Duplex mast ZT		2500 mm	1750 mm	100 mm	2975 mm
		2700 mm	1850 mm	100 mm	3175 mm
		2900 mm	1950 mm	100 mm	3375 mm
		3200 mm	2100 mm	100 mm	3675 mm
		3600 mm	2300 mm	100 mm	4075 mm
		4100 mm	2550 mm	100 mm	4575 mm
		4300 mm	2650 mm	100 mm	4775 mm
		4500 mm	2750 mm	100 mm	4975 mm
Duplex mast ZZ		2500 mm	1700 mm	1225 mm	2975 mm
		2900 mm	1900 mm	1425 mm	3375 mm
		3200 mm	2050 mm	1575 mm	3675 mm

	3600 mm	2250 mm	1775 mm	4075 mm
	4100 mm	2500 mm	2025 mm	4575 mm
	4300 mm	2600 mm	2125 mm	4775 mm
Triplex mast DZ	4090 mm	1830 mm	1341 mm	4579 mm
	4300 mm	1900 mm	1411 mm	4789 mm
	4690 mm	2030 mm	1541 mm	5179 mm
	5350 mm	2250 mm	1761 mm	5839 mm
EJC 214, EJC 216	Lift (h3)	Retracted mast height (h1)	Free lift (h2)	Extended mast height (h4)
Triplex mast DZ	6000 mm	2500 mm	1968 mm	6532 mm
EJC 216	Lift (h3)	Retracted mast height (h1)	Free lift (h2)	Extended mast height (h4)
Duplex mast ZT	2400 mm	1750 mm	100 mm	2925 mm
	2600 mm	1850 mm	100 mm	3125 mm
	2800 mm	1950 mm	100 mm	3325 mm
	3100 mm	2100 mm	100 mm	3625 mm
	3500 mm	2300 mm	100 mm	4025 mm
	3800 mm	2450 mm	100 mm	4325 mm
	4000 mm	2550 mm	100 mm	4525 mm
	4200 mm	2650 mm	100 mm	4725 mm
	4400 mm	2750 mm	100 mm	4925 mm
Duplex mast ZZ	2400 mm	1700 mm	1175 mm	2925 mm
	2800 mm	1900 mm	1375 mm	3325 mm
	3100 mm	2050 mm	1525 mm	3625 mm
	3500 mm	2250 mm	1725 mm	4025 mm
	4000 mm	2500 mm	1975 mm	4525 mm
	4200 mm	2600 mm	2075 mm	4725 mm
Triplex mast DZ	3990 mm	1830 mm	1298 mm	4522 mm
	4200 mm	1900 mm	1368 mm	4732 mm
	4590 mm	2030 mm	1498 mm	5122 mm
	5250 mm	2250 mm	1718 mm	5782 mm

EJC 220		Lift (h3)	Retracted mast height (h1)	Free lift (h2)	Extended mast height (h4)
Duplex mast ZT	2540 mm	1950 mm	100 mm	3195 mm	
	2840 mm	2100 mm	100 mm	3495 mm	
	3540 mm	2450 mm	100 mm	4195 mm	
Duplex mast ZZ	2540 mm	1900 mm	1245 mm	3195 mm	
	2840 mm	2050 mm	1395 mm	3495 mm	
	3540 mm	2400 mm	1745 mm	4195 mm	
Triplex mast DZ	3750 mm	1900 mm	1218 mm	4432 mm	
	4200 mm	2050 mm	1368 mm	4882 mm	
	4800 mm	2250 mm	1568 mm	5482 mm	
EJC 230		Lift (h3)	Retracted mast height (h1)	Free lift (h2)	Extended mast height (h4)
Duplex mast ZT	2800 mm	2075 mm	100 mm	3558 mm	
Triplex mast DZ	4250 mm	2075 mm	1320 mm	5006 mm	
	4700 mm	2225 mm	1470 mm	5456 mm	

VDI table

		Jungheinrich							
		EJC 212	EJC 214	EJC 216	EJC 220	EJC 230			
Characteristic	1.1	Manufacturer (abbreviated description)							
	1.2	Manufacturer's type designation							
	1.3	Drive type	electric						
	1.4	Operation	Pedestrian						
	1.5	Load capacity/load	Q kg	1200	1400	1600	2000	3000	
	1.6	Load centre distance	c mm	600					
	1.8	Load distance, centre of drive axle to fork	x mm	689	668			635	
	1.9	Wheelbase	y mm	1196	1264		1336	1470	
	Weights	2.1.1	Service weight (incl. battery)	kg	880	1039	1044	1207	1952
2.2		Axle load laden front/rear	kg	660 / 1420	794 / 1645	814 / 1830	878 / 2329	1409 / 3523	
2.3		Axle load unladen front/rear	kg	590 / 290	721 / 318	724 / 320	805 / 402	1259 / 693	
Wheels/chassis	3.1	Tyres	Polyurethane (PU)						
	3.2	Tyre size, front	Ø 230 x 70						
	3.3	Tyre size, rear	Ø 85 x 110		Ø 85 x 85	Ø 85 x 110			
	3.4	Additional wheels	Ø 140 x 54						
	3.5	Wheels, number front/back (x=driven)	1x + 1 / 2			1x + 1 / 4			
	3.6	Tread width, front	b10 mm	507					
	3.7	Tread width, rear	b11 mm	400			370		
Basic dimensions	4.2	Retracted mast height (h1)	h1 mm	1950		2100	2075		
	4.3	Free lift (h2)	h2 mm	100					
	4.4	Lift (h3)	h3 mm	2900	2800	2840	2800		
	4.5	Extended mast height (h4)	h4 mm	3375	3325	3495	3558		
	4.9	Height of tiller handle in drive position min./max.	h14 mm	850 / 1305					
	4.15	Height, lowered	h13 mm	90			95		
	4.19	Total length	l1 mm	1827	1916	1988	2129		
	4.20	Length including fork shank	l2 mm	677	766	838	979		
	4.21.1	total width	b1 mm	800					
	4.22	Fork dimensions	s/ e/l mm	56 x 185 x 1150				85 x 210 x 1150	
	4.23	Fork carriage connection class		2A			2B		
	4.25	Width across forks	b5 mm	570			580		
	4.32	Ground clearance centre of wheelbase	m2 mm	28	25	18	20		
	4.34.1	Aisle width (pallet 1000x1200 sideways)	Ast mm	2068	2178	2250	-		
4.34.2	Aisle width (pallet 800x1200 length)	Ast mm	2118	2228	2300	2532			
4.35	Turning radius	Wa mm	1407	1496	1568	1720			
Performance data	5.1	Travel speed laden/unladen	km/h	6 / 6				5.5 / 5.5	
	5.2	Lift speed laden/unladen	m/s	0.2 / 0.4	0.16 / 0.3	0.15 / 0.3	0.11 / 0.34	0.07 / 0.15	
	5.3	Lowering speed laden/unladen	m/s	0.45 / 0.35			0.5 / 0.35	0.25 / 0.25	
	5.8	Max. gradeability laden/unladen	%	8 / 16		7 / 16	5 / 16	2 / 14	

Electric motor/electronics	6.1	Drive motor, performance S2 60 min	kW	1	1.6			
	6.2	Lift motor, performance with S3	kW	3				
	6.3	Battery according to DIN 43531/35/36		no				
	6.4	Battery voltage/nominal capacity	V / Ah	24 / 200	24 / 300		24 / 375	
	6.5	Battery weight	kg	185	243		288	
	6.6	Energy consumption according to VDI cycle	kWh/h	1.05	1.18	1.32	-	
	6.6.1	Energy consumption according to EN cycle	kWh/h	0.77	0.83	0.91	1.08	0.92
	6.6.2	CO2 equivalent according to EN ISO 23308	kg/h0	0.4		0.5	0.6	0.5
Other	8.1	Type of drive control		AC				
	10.7	Sound pressure level according to EN12053	dB (A)	63			70	
<p>- This data sheet according to VDI guideline 2198 only states the technical values of the standard truck. Different tyres, other masts, additional equipment etc. may result in different values.</p>								

The values in the table apply for the battery compartment S-VBE (EJC 212), M-VBE (EJC 214 / 216), L-VBE (EJC 220 / 230), mast ZT 2,800 / 2,840 / 2,900 mm.

- VDI no. 1.8 with EJC 212 / 214 / 216: with DZ mast: x - 42 mm.
- VDI no. 1.8 with EJC 220: with L-VBE or L-SBE battery compartment and DZ mast: x - 1 mm, M Li-ion and DZ mast: x - 71 mm.
- VDI no. 1.8 with EJC 230: with DZ mast: x - 104 mm.
- VDI no. 1.9 with EJC 212: with battery compartment M-VBE or M Li-ion: y + 68 mm, L-VBE or L-SBE: y + 140 mm.
- VDI no. 1.9 with EJC 214 / 216: with M Li-ion battery compartment: y + 0 mm, L-VBE or L-SBE: y + 72 mm.
- VDI no. 1.9 with EJC 220: with L-VBE or L-SBE battery compartment and DZ mast: y + 70 mm, M Li-ion: y - 72 mm.
- VDI no. 1.9 with EJC 230: with DZ mast: y + 104 mm.
- VDI no. 3.3 with EJC 212 / 214 / 216: tandem: Ø 85 x 85 mm.
- VDI no. 4.19 with EJC 212: with DZ mast: l1 + 42 mm; with M-VBE or M Li-ion battery compartment: l1 + 68 mm, L-VBE or L-SBE: l1 + 140 mm.
- VDI no. 4.19 with EJC 214/216: with DZ mast: l1 + 42 mm; with M Li-ion battery compartment: l1 + 0 mm, L-VBE or L-SBE: l1 + 72 mm.
- VDI no. 4.19 with EJC 220: with DZ mast: l1 + 71 mm; with battery compartment M Li-ion: l1 - 72 mm.
- VDI no. 4.19 with EJC 230: with DZ mast: l1 + 26 mm.
- VDI no. 4.20 with EJC 212: with DZ mast: l2 + 42 mm; with M-VBE or M Li-ion battery compartment: l2 + 68 mm, L-VBE or L-SBE: l2 + 140 mm.
- VDI no. 4.20 with EJC 214/216: with DZ mast: l2 + 42 mm; with M Li-ion battery compartment: l2 + 0 mm, L-VBE or L-SBE: l2 + 72 mm.
- VDI no. 4.20 with EJC 220: with DZ mast: l2 + 71 mm; with battery compartment M Li-ion: l2 - 72 mm.
- VDI no. 4.20 with EJC 230: with DZ mast: l2 + 26 mm.
- VDI no. 4.34.1 with EJC 212: diagonal as per VDI: aisle width + 215 mm; with M-VBE or M Li-ion battery compartment: aisle width + 68 mm, L-VBE or L-SBE: aisle width + 140 mm; with DZ mast: aisle width + 42 mm.
- VDI no. 4.34.1 with EJC 214 / 216: diagonal as per VDI: aisle width + 215 mm; with M Li-ion battery compartment: aisle width + 0 mm, L-VBE or L-SBE: aisle width + 72 mm; with DZ mast: aisle width + 42 mm.
- VDI no. 4.34.1 with EJC 220: diagonal as per VDI: aisle width + 215 mm; with DZ mast: aisle width + 71 mm; with M Li-ion battery compartment: aisle width - 72 mm.
- VDI no. 4.34.2 with EJC 212: diagonal as per VDI: aisle width + 138 mm; with M-VBE or M Li-ion battery compartment: aisle width + 68 mm, L-VBE or L-SBE: aisle width + 140 mm; with DZ mast: aisle width + 42 mm.
- VDI no. 4.34.2 with EJC 214 / 216: diagonal as per VDI: aisle width + 138 mm; with M Li-ion battery compartment: aisle width + 0 mm, L-VBE or L-SBE: aisle width + 72 mm; with DZ mast: aisle width + 42 mm.
- VDI no. 4.34.2 with EJC 220: diagonal as per VDI: aisle width + 138 mm; with DZ mast: aisle width + 71 mm; with M Li-ion battery compartment: aisle width - 72 mm.
- VDI no. 4.34.2 with EJC 230: diagonal as per VDI: aisle width + 240 mm; with DZ mast: aisle width = 2,574 mm.

- VDI no. 4.35 with EJC 212: with M-VBE or M Li-ion battery compartment: Wa + 68 mm, L-VBE or L-SBE: Wa + 140 mm.
- VDI no. 4.35 with EJC 214/216: with M Li-ion battery compartment: Wa + 0 mm, L-VBE or L-SBE: Wa + 72 mm.
- VDI no. 4.35 with EJC 220: with L-VBE or L-SBE battery compartment and DZ mast: Wa + 70 mm.
- VDI no. 4.35 with EJC 230: with DZ mast: Wa = 1,760 mm.
- VDI no. 5.1 with EJC 230: in load direction 5 km/h.
- VDI no. 5.3: with ZZ / DZ mast: the lowering speed in free lift is below the specified values.

The German production facilities in
Norderstedt, Moosburg and Landsberg are
certified as well as our Genuine Parts
Center in Kaltenkirchen.

ISO 9001
ISO 14001

Jungheinrich fork lift trucks meet European
safety requirements.



 **JUNGHEINRICH**