



Electric four wheel counterbalance forklift truck

CBH 2.0 (AU & NZ)

Lift height: 3000-4500 mm / Load capacity: 2000 kg



CBH 2.0 (AU & NZ)

Trucks that simply work.

Built for use in changing environments.

The AntOn by Jungheinrich CBH electric forklift truck combines everything that matters in demanding daily operation: robust technology, easy handling and reliable performance. Whether in the warehouse, outdoors or at the loading ramp: the CBH is versatile and delivers exactly where it is needed. This electric forklift truck will always make your job easier – from internal transport, manoeuvrable applications in confined spaces and the rapid loading and unloading of HGVs. It excels not only in daily use but also through its fast availability and a price/performance ratio that makes transitioning to electromobility particularly appealing.

With modern lithium-ion power, the CBH provides exactly the flexibility your business needs today – making it an easy choice: a truck that simply works.

All benefits at a glance

- Reliable technology for everyday use.
- Robust design to meet a wide range of requirements.
- Simple operation for comfortable handling.
- Lithium-ion technology for rapid charging and consistent performance.
- High availability for fast delivery.

Versatile

Functional power for every job.

- Various capacity options, to match different applications, needs and budgets.
- Super-elastic (SE) tyres, solid rubber tyres or abrasion-resistant tyres.
- Compact and highly manoeuvrable – even in tight spaces.
- Large tyres and high ground clearance for outdoor use on uneven ground.
- Charging with an external charger.

Straightforward

Intuitive technology that makes work easier.

- LED display with all key information at a glance.
- Simple control elements – from the control panel and comfortable pedal to the water-resistant charging port.
- Optimum visibility for safer daily operation.
- Ergonomic operator position, adjustable steering wheel and generous legroom.

Cost-effective

Solutions for every task and every budget.

- Maintenance-free 80-V lithium-ion battery for long service life and short charging pauses.
- Rapid lift speeds save time with every application.
- High availability and cost-efficient acquisition.
- Fast spare parts supply keeps your operations running smoothly.

VDI table

Characteristic	1.1	Manufacturer (abbreviated description)			Jungheinrich
	1.3	Drive			Electric
	1.4	Operation			Seat
	1.5	Load capacity/load	Q	kg	2000
	1.6	Load centre distance	c	mm	500
	1.8	Load distance, centre of drive axle to fork	x	mm	495
	1.9	Wheelbase	y	mm	1540
	Weights	2.1.1	Service weight (incl. battery)		kg
2.2		Axle load laden front/rear		kg	4930 / 619
2.3		Axle load unladen front/rear		kg	1635 / 1909
Wheels/suspension system	3.1	Tyres			Super-elastic (SE)
	3.2	Tyre size, front			7.00-12
	3.3	Tyre size, rear			18x7-8
	3.5	Wheels, number front/back (x=driven)			2x / 2
	3.6	Tread width, front	b10	mm	975
	3.7	Tread width, rear	b11	mm	955
	Basic dimensions	4.2	Retracted mast height (h1)	h1	mm
4.3		Free lift (h2)	h2	mm	120
4.4		Lift (h3)	h3	mm	3000
4.5		Extended mast height (h4)	h4	mm	4025
4.7		Height of overhead guard (cab)	h6	mm	2165
4.8		Seat height/stand height	h7	mm	1095
4.12		Coupling height	h10	mm	310
4.19		total length	l1	mm	3535
4.20		Length including fork shank	l2	mm	2385
4.21.1		total width	b1	mm	1154
4.22		Fork dimensions	s/e/l	mm	40 x 122 x 1150
4.23		Fork carriage connection class			2A
4.24		Fork carriage width	b3	mm	1040
4.31		Ground clearance laden under mast	m1	mm	125
4.32		Ground clearance centre of wheelbase	m2	mm	150
4.34.1		Aisle width (pallet 1000x1200 sideways)	Ast	mm	3824
4.34.2		Aisle width (pallet 800x1200 length)	Ast	mm	4024
4.35	Turning radius	Wa	mm	2129	
4.36	Smallest pivot point distance	b13	mm	662	
Performance data	5.1	Travel speed laden/unladen		km/h	14 / 15
	5.2	Lift speed laden/unladen		m/s	0.29 / 0.36
	5.3	Lowering speed laden/unladen		m/s	0.43 / 0.44
	5.5	Drawbar pull laden/unladen		N	2090 / 2090
	5.6	Max. drawbar pull laden/unladen		N	12570 / 12570
	5.7	Gradeability laden/unladen		%	7 / 14
	5.8	Max. gradeability laden/unladen		%	15 / 20
	5.9	Acceleration time laden/unladen		s	7.9 / 7.5
	5.10	Service brake			hydraulic

E-motor/Electronics	6.1	Drive motor, performance S2 60 min	kW	10
	6.2	Lift motor, performance with S3	kW	16
	6.4	Battery voltage/nominal capacity	V / Ah	80 / 230
	6.6.1	Energy consumption according to EN cycle	kWh/h	6.77
	6.6.2	CO2 equivalent according to EN ISO 23308	kg/h0	3.7
	6.7	Throughput	t/h	116
	6.8.1	Energy consumption with max. throughput	kWh/h	5.88
Other	8.1	Type of drive control		AC
	10.1	Operating pressure for attachment	bar	180
	10.2	Oil flow for attachments	l/min	35
	10.7	Sound pressure level according to EN12053	dB (A)	74

- This data sheet according to VDI guideline 2198 only states the technical values of the standard truck. Different tyres, other masts, additional equipment etc. may result in different values.

Appendix

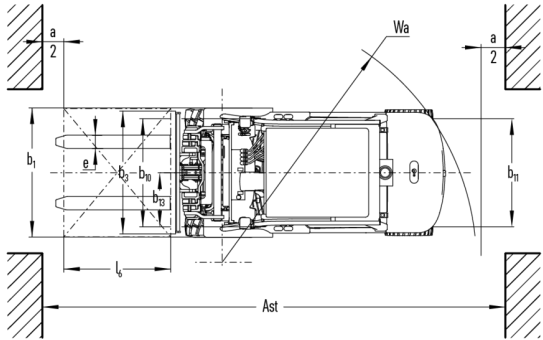
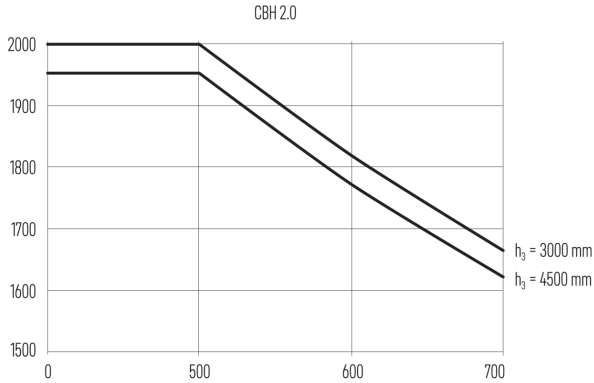
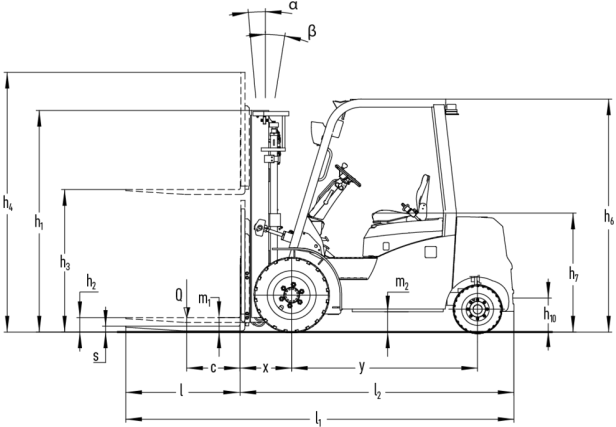

The German production facilities in
Norderstedt, Moosburg and Landsberg are
certified as well as our Genuine Parts
Center in Kaltenkirchen. ISO 9001
ISO 14001

anton
BY JUNGHEINRICH