



Electric pedestrian pallet truck

AME 20

Lift height: 115 mm / Load capacity: 2000 kg

AME 20

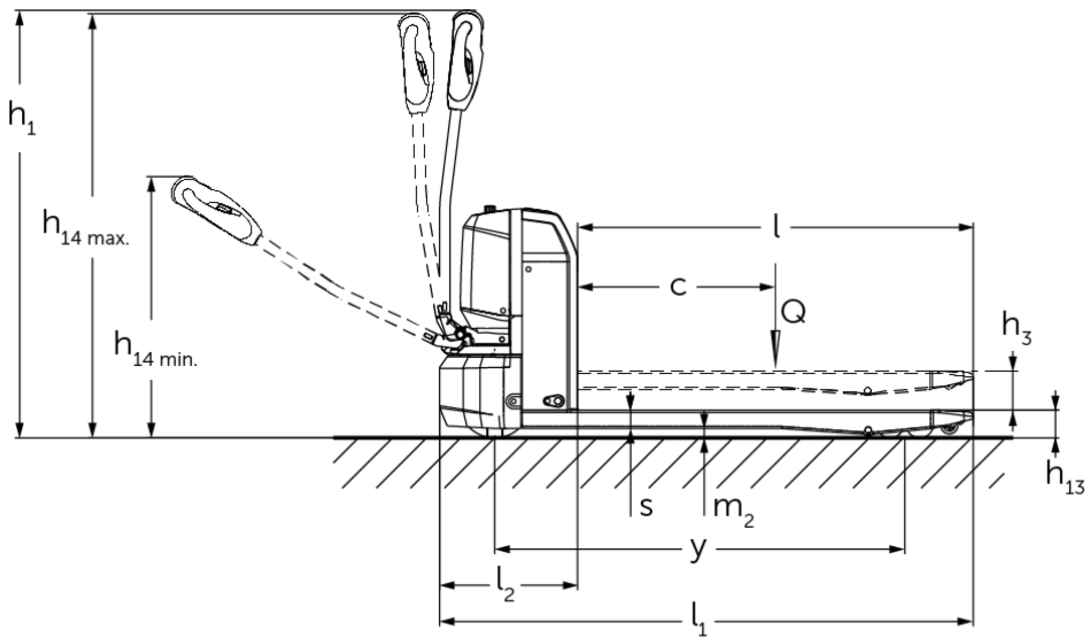



VDI table

		Manufacturer (abbreviated description)	Jungheinrich								
Characteristic	1.1	Manufacturer (abbreviated description)	Jungheinrich								
	1.2	Manufacturer's type designation	AME 20 (530x800, V-BV)	AME 20 (530x1000, V-BV)	AME 20 (530x1150, V-BV)	AME 20 (530x1150, V-GV)	AME 20 (530x1210, V-BV)	AME 20 (670x1000, V-BV)	AME 20 (670x1150, V-BV)	AME 20 (670x1150, V-GV)	
	1.3	Drive type	electric								
	1.4	Operation	Pedestrian								
	1.5	Load capacity/load	Q kg	2000							
	1.6	Load centre distance	c mm	600							
	1.8	Load distance, centre of drive axle to fork	x mm	602	802	952		1012	802	952	
	1.9	Wheelbase	y mm	843	1043	1193		1253	1043	1193	
	Weights	2.1.1	Service weight (incl. battery)	kg	145	153	158		160	161	166
2.2		Axle load laden front/rear	kg	725 / 1420	728 / 1425	729 / 1429		730 / 1430	734 / 1427	736 / 1430	
2.3		Axle load unladen front/rear	kg	119 / 26	125 / 28	128 / 30		130 / 30	133 / 28	136 / 30	
Wheels/chassis	3.1	Tyres	Polyurethane (PU)								
	3.2	Tyre size, front	Ø210 x 70								
	3.3	Tyre size, rear	Ø80 x 70 (Ø80 x 93)								
	3.4	Additional wheels	Ø62,5 x 45								
	3.5	Wheels, number front/back (x=driven)	1x + 2 / 4 (1x + 2 / 2)								
	3.6	Tread width, front	b10 mm	390				530			
	3.7	Tread width, rear	b11 mm	370				510			
Basic dimensions	4.2.1	Total height	h15 mm	673							
	4.4	Lift (h3)	h3 mm	115							
	4.9	Height of tiller handle in drive position min./max.	h14 mm	700 / 1190							
	4.15	Height, lowered	h13 mm	80							
	4.19	Total length	l1 mm	1200	1400	1550		1610	1400	1550	
	4.20	Length including fork shank	l2 mm	400							
	4.21.1	total width	b1 mm	530				670			
	4.22	Fork dimensions	s/e/l mm	53 x 160 x 800	53 x 160 x 1000	53 x 160 x 1150		53 x 160 x 1210	53 x 160 x 1000	53 x 160 x 1150	
	4.25	Width across forks	b5 mm	530				670			
	4.32	Ground clearance centre of wheelbase	m2 mm	27							
4.34.2	Aisle width (pallet 800x1200 length)	Ast mm	1958	2003	2060		2090	2003	2060		
4.35	Turning radius	Wa mm	1039	1239	1389		1449	1239	1389	1449	

Performance data	5.1	Travel speed laden/unladen	km/h	5 / 5.5
	5.2	Lift speed laden/unladen	m/s	0.03 / 0.04
	5.3	Lowering speed laden/unladen	m/s	0.06 / 0.05
	5.8	Max. gradeability laden/unladen	%	7 / 20
	5.10	Service brake		electromagnetic
Electric motor/electronics	6.1	Drive motor, performance S2 60 min	kW	1
	6.2	Lift motor, performance with S3	kW	0.8
	6.4	Battery voltage/nominal capacity	V / Ah	48 / 25
	6.5	Battery weight	kg	10.5
	6.6	Energy consumption according to VDI cycle	kWh/h	0.16
	Other	8.1	Type of drive control	
10.7		Sound pressure level according to EN12053	dB (A)	70

- This data sheet according to VDI guideline 2198 only states the technical values of the standard truck. Different tyres, other masts, additional equipment etc. may result in different values.

- VDI no. 4.2.1: overall height h15 = height of the truck without tiller.