



Elektrische stapelaar met dwarsgeplaatste zitplaats

ESC 214-316 / 214z-316z

Hefhoogte: 2800-6200 mm / Draagvermogen: 1400-1600 kg



ESC 214-316 / 214z-316z

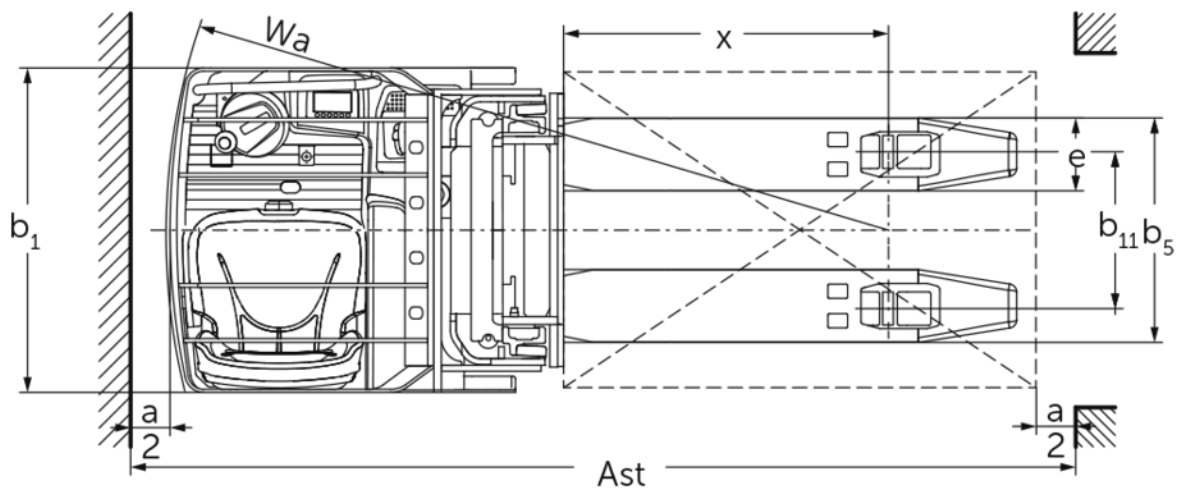



ESC 214-316 / 214z-316z

ESC 214, ESC 214z	Heffing (h3)	Ingeschoven masthoogte (h1)	Vrije heffing (h2)	Uitgeschoven masthoogte (h4)	Hoogte beschermend dak (cabine)
Drievoudige mast DZ	4300 mm	1945 mm	1426 mm	4830 mm	2093 mm
	5350 mm	2295 mm	1776 mm	5880 mm	2288 mm
Tweevoudige mast ZT	2900 mm	2015 mm	100 mm	3422 mm	2093 mm
	3200 mm	2165 mm	100 mm	3722 mm	2243 mm
	3600 mm	2365 mm	100 mm	4122 mm	2288 mm
	4100 mm	2615 mm	100 mm	4622 mm	2288 mm
	4300 mm	2715 mm	100 mm	4822 mm	2288 mm
Tweevoudige mast ZZ	2900 mm	1965 mm	1420 mm	3422 mm	2093 mm
	3200 mm	2115 mm	1570 mm	3722 mm	2243 mm
	3600 mm	2315 mm	1770 mm	4122 mm	2288 mm
	4100 mm	2565 mm	2020 mm	4622 mm	2288 mm
	4300 mm	2665 mm	2120 mm	4822 mm	2288 mm
ESC 216, ESC 216z, ESC 316, ESC 316z	Heffing (h3)	Ingeschoven masthoogte (h1)	Vrije heffing (h2)	Uitgeschoven masthoogte (h4)	Hoogte beschermend dak (cabine)
Drievoudige mast DZ	4200 mm	1945 mm	1376 mm	4770 mm	2093 mm
	5250 mm	2295 mm	1726 mm	5820 mm	2288 mm
	6200 mm	2615 mm	2046 mm	6790 mm	2288 mm
Tweevoudige mast ZT	2800 mm	2015 mm	100 mm	3372 mm	2093 mm
	3100 mm	2165 mm	100 mm	3672 mm	2243 mm
	3500 mm	2365 mm	100 mm	4072 mm	2288 mm
	4000 mm	2615 mm	100 mm	4572 mm	2288 mm
	4200 mm	2715 mm	100 mm	4772 mm	2288 mm
Tweevoudige mast ZZ	2800 mm	1965 mm	1373 mm	3372 mm	2093 mm
	3100 mm	2115 mm	1523 mm	3672 mm	2243 mm
	3500 mm	2315 mm	1723 mm	4072 mm	2288 mm
	4000 mm	2565 mm	1973 mm	4572 mm	2288 mm
	4200 mm	2665 mm	2073 mm	4772 mm	2288 mm

VDI-tabel

Kenmerken	1.1	Fabrikant (korte naam)		Jungheinrich						
	1.2	Typeaanduiding fabrikant		ESC 214	ESC 216	ESC 214z	ESC 216z	ESC 316	ESC 316z	
	1.3	Aandrijving		Elektrisch						
	1.4	Bediening		Stoel						
	1.5	Draagvermogen/last	Q kg	1400	1600	1400	1600			
	1.6	Lastzwaartepuntafstand	c mm	600						
	1.8	Lastafstand	x mm	860		874		860	874	
	1.9	Wielbasis	y mm	1656		1685		1656	1700	
	Gewichten	2.1.1	Eigen gewicht (incl. accu)	kg	1590		1660		1746	1685
2.2		Aslast met last voor/achter	kg	1316 / 1674	1340 / 1850	1285 / 1775	1370 / 1890	1459 / 1228	1432 / 1857	
2.3		Aslast onbelast voor/achter	kg	1113 / 477		1162 / 498		1891 / 518	1190 / 495	
Wielen/chassis	3.1	Banden		Polyurethaan (PU)						
	3.2	Bandenmaat, voor		Ø 230 x 77						
	3.3	Bandenmaat, achter		Ø 85 x 85						
	3.4	Extra wielen		Ø 140 x 126						
	3.5	Wielen, aantal voor/achter (x = aangedreven)		2 + 1x / 4						
	3.6	Spoorbreedte, voor	b10 mm	544				645		
	3.7	Spoorbreedte, achter	b11 mm	385						
Afmetingen	4.2	Ingeschoven masthoogte (h1)	h1 mm	1995						
	4.3	Vrije heffing (h2)	h2 mm	100						
	4.4	Heffing (h3)	h3 mm	2900	2800	2900	2800			
	4.5	Uitgeschoven masthoogte (h4)	h4 mm	3422						
	4.6	Initiële heffing	h5 mm	-		125		-	125	
	4.7	Hoogte beschermend dak (cabine)	h6 mm	2095						
	4.8	Zithoogte / stahoogte	h7 mm	1020						
	4.15	Gedaalde hoogte	h13 mm	90						
	4.19	Totale lengte	l1 mm	2125		2140		2125	2155	
	4.20	Lengte inclusief vorkrug	l2 mm	975		990		975	1005	
	4.21.1	Totale breedte	b1 mm	820				930		
	4.22	Vorkafmetingen	s/ e/l mm	60 x 185 x 1150						
	4.25	Maat over de vorken	b5 mm	570						
	4.32	Bodemvrijheid midden wielbasis	m2 mm	30		25		30	25	
	4.34.1	Werkbreedte (pallet 1000 x 1200 dwars)	Ast mm	-				2353	2383	
4.34.2	Werkbreedte (pallet 800x1200 longitudinaal)	Ast mm	2383		2398		2403	2433		
4.35	Draaicirkel	Wa mm	1843		1872		1863	1907		
Prestaties	5.1	Rijsnelheid met last/onbelast	km/u	9,1 / 9,1						
	5.2	Hefsnelheid met last/onbelast	m/s	0,15 / 0,24	0,13 / 0,24	0,14 / 0,23		0,13 / 0,24	0,14 / 0,23	
	5.3	Daalsnelheid met last/onbelast	m/s	0,42 / 0,42		0,42 / 0,38		0,42 / 0,42	0,42 / 0,38	
	5.7	Nominale helling met last/onbelast	%	7 / 12						
	5.10	Rem		elektrisch						

E-motor/elektronica	6.1	Rijmotor, vermogen S2 60 min	kW	2,8				
	6.2	Hefmotor, vermogen bij S3	kW	3				
	6.3	Accu volgens DIN 43531/35/36		nee				
	6.4	Accuspanning/nominaal vermogen	V / Ah	24 / 465				
	6.5	Accugewicht	kg	380				
	6.6	Energieverbruik volgens VDI-cyclus	kWh/u	0		2,5		
	6.6.1	Energieverbruik volgens EN-cyclus	kWh/u	0,94	1,02	0,94	1,02	1,04
	6.6.2	CO2-equivalent volgens EN ISO 23308	kg/h0	0,5				
Overig	8.1	Type rijregeling		AC				
<p>- Dit typeblad volgens VDI-richtlijn 2198 noemt alleen de technische waarden van de standaardmachine. Afwijkende banden, andere hefmasten, extra systemen etc. kunnen resulteren in andere waarden.</p>								

De waarden in de tabel gelden voor hefmast ZT 2800 / 2900, wielarmheffing gedaald.

VDI-nr. 1.8: bij ESC 214z / 216z / 316z: wielarmheffing geheven: x - 78 mm.

VDI-nr. 1.9: bij ESC 214z / 216z / 316z: wielarmheffing geheven: y - 78 mm.

VDI-nr. 4.34.2: diagonaal volgens VDI: gangpadbreedte + 190 mm.

VDI-nr. 4.35: bij ESC 214z / 216z / 316z: wielarmheffing geheven: Wa - 78 mm.

De Duitse fabrieken in Norderstedt,
Moosburg en Landsberg zijn gecertificeerd,
evenals ons onderdelenmagazijn in
Kaltenkirchen. ISO 9001
ISO 14001

Jungheinrich intern transport materieel
voldoet aan de Europese
veiligheidsvoorschriften. 

**JUNGHEINRICH**