



Electric pedestrian pallet truck

EJE 114i-120i

Lift height: 122 mm / Load capacity: 1400-2000 kg



EJE 114i-120i

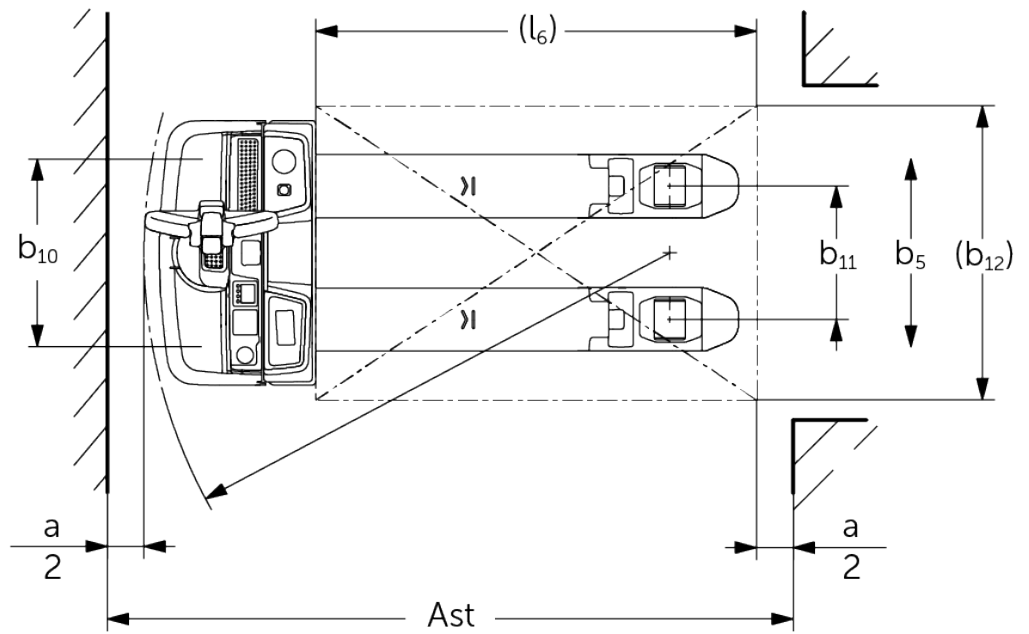
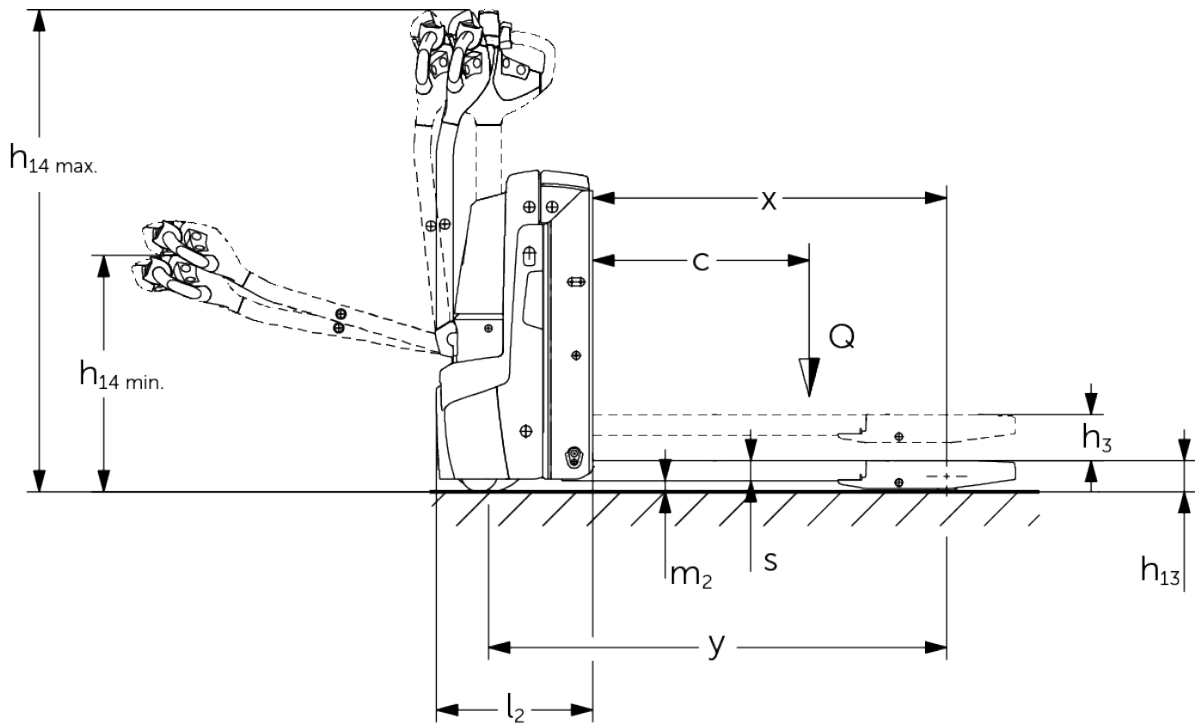

VDI table

Characteristic	1.1	Manufacturer (abbreviated description)		Jungheinrich			
	1.3	Drive		Electric			
	1.4	Operation		Pedestrian			
	1.5	Load capacity/load	Q kg	1400	1600	1800	2000
	1.6	Load centre distance	c mm	600			
	1.8	Load distance, centre of drive axle to fork	x mm	897			
	1.9	Wheelbase	y mm	1180			
Weights	2.1.1	Service weight (incl. battery)	kg	311	315		
	2.2	Axle load laden front/rear	kg	685 / 1026	757 / 1158	772 / 1343	776 / 1539
	2.3	Axle load unladen front/rear	kg	244 / 67	246 / 69		
Wheels/suspension system	3.1	Tyres		Polyurethane (PU)			
	3.2	Tyre size, front		Ø 230 x 70			
	3.3	Tyre size, rear		Ø 85 x 95	Ø 85 x 110		
	3.4	Additional wheels		Ø 100 x 40			
	3.5	Wheels, number front/back (x=driven)		1x + 2 / 2			
	3.6	Tread width, front	b10 mm	510			
	3.7	Tread width, rear	b11 mm	363			
Basic dimensions	4.4	Lift (h3)	h3 mm	122			
	4.9	Height of tiller handle in drive position min./max.	h14 mm	690 / 1235			
	4.15	Height, lowered	h13 mm	85			
	4.19	total length	l1 mm	1575			
	4.20	Length including fork shank	l2 mm	425			
	4.21.1	total width	b1 mm	720			
	4.22	Fork dimensions	s/e/ l mm	55 x 150 x 1150	55 x 172 x 1150		
	4.25	Width across forks	b5 mm	513	535		
	4.32	Ground clearance centre of wheelbase	m2 mm	30			
	4.34.1	Aisle width (pallet 1000x1200 sideways)	Ast mm	2173			
4.34.2	Aisle width (pallet 800x1200 length)	Ast mm	2066				
4.35	Turning radius	Wa mm	1364				
Performance data	5.1	Travel speed laden/unladen	km/h	5 / 5	6 / 6		
	5.2	Lift speed laden/unladen	m/s	0.03 / 0.03	0.05 / 0.06		
	5.3	Lowering speed laden/unladen	m/s	0.05 / 0.02	0.06 / 0.05		
	5.8	Max. gradeability laden/unladen	%	8 / 20	10 / 20		
	5.10	Service brake		generative			

E-motor/Electronics	6.1	Drive motor, performance S2 60 min	kW	0.9	1.1		
	6.2	Lift motor, performance with S3	kW	1.2			
	6.3	Battery according to DIN 43531/35/36		no			
	6.4	Battery voltage/nominal capacity	V / Ah	25.6 / 50			
	6.5	Battery weight	kg	23.8			
	6.6.1	Energy consumption according to EN cycle	kWh/h	0.3	0.31	0.33	0.35
	6.6.2	CO2 equivalent according to EN ISO 23308	kg/h0	0.2			
	6.7	Throughput	t/h	59	101	117	129
Other	8.1	Type of drive control		AC			
	10.7	Sound pressure level according to EN12053	dB (A)	61	58		
<p>- This data sheet according to VDI guideline 2198 only states the technical values of the standard truck. Different tyres, other masts, additional equipment etc. may result in different values.</p>							

The specified values refer to the XS battery compartment with 50-Ah battery and raised load section.

- VDI no. 1.8: lowered load section: $x + 67$ mm.
- VDI no. 1.9: with S battery compartment: $y + 50$ mm; load section: $y + 67$ mm.
- VDI no. 3.3: applies for single load wheel; EJE 114i: with tandem: $\emptyset 82 \times 70$; with triplex: $\emptyset 82 \times 35$; EJE 116i - 120i: with tandem: $\emptyset 82 \times 85$; with triplex: $\emptyset 82 \times 42$.
- VDI no. 4.15: with tandem rollers and triplex rollers h_{13} is = 83 mm.
- VDI no. 4.19: with S battery compartment: $l_1 + 50$ mm.
- VDI no. 4.20: with S battery compartment: $l_2 + 50$ mm.
- VDI no. 4.34.1: with S battery compartment: aisle width + 50 mm.
- VDI no. 4.34.2: with S battery compartment: aisle width + 50 mm.
- VDI no. 4.35: with S battery compartment: $W_a + 50$ mm; load section lowered: $W_a + 67$ mm.
- VDI no. 6.2: lift motor, performance with 4.5% ED.

The German production facilities in
Norderstedt, Moosburg and Landsberg are
certified as well as our Genuine Parts
Center in Kaltenkirchen.

ISO 9001
ISO 14001

Jungheinrich fork lift trucks meet European
safety requirements.



 **JUNGHEINRICH**

The Jungheinrich logo, featuring a red upward-pointing arrow above the word 'JUNGHEINRICH' in a bold, black, sans-serif font.