



## Electric pedestrian stacker

**EJC MA 112 + B12**

Lift height: 2440-3600 mm / Load capacity: 1200 kg

**JUNGHEINRICH**

# EJC MA 112 + B12

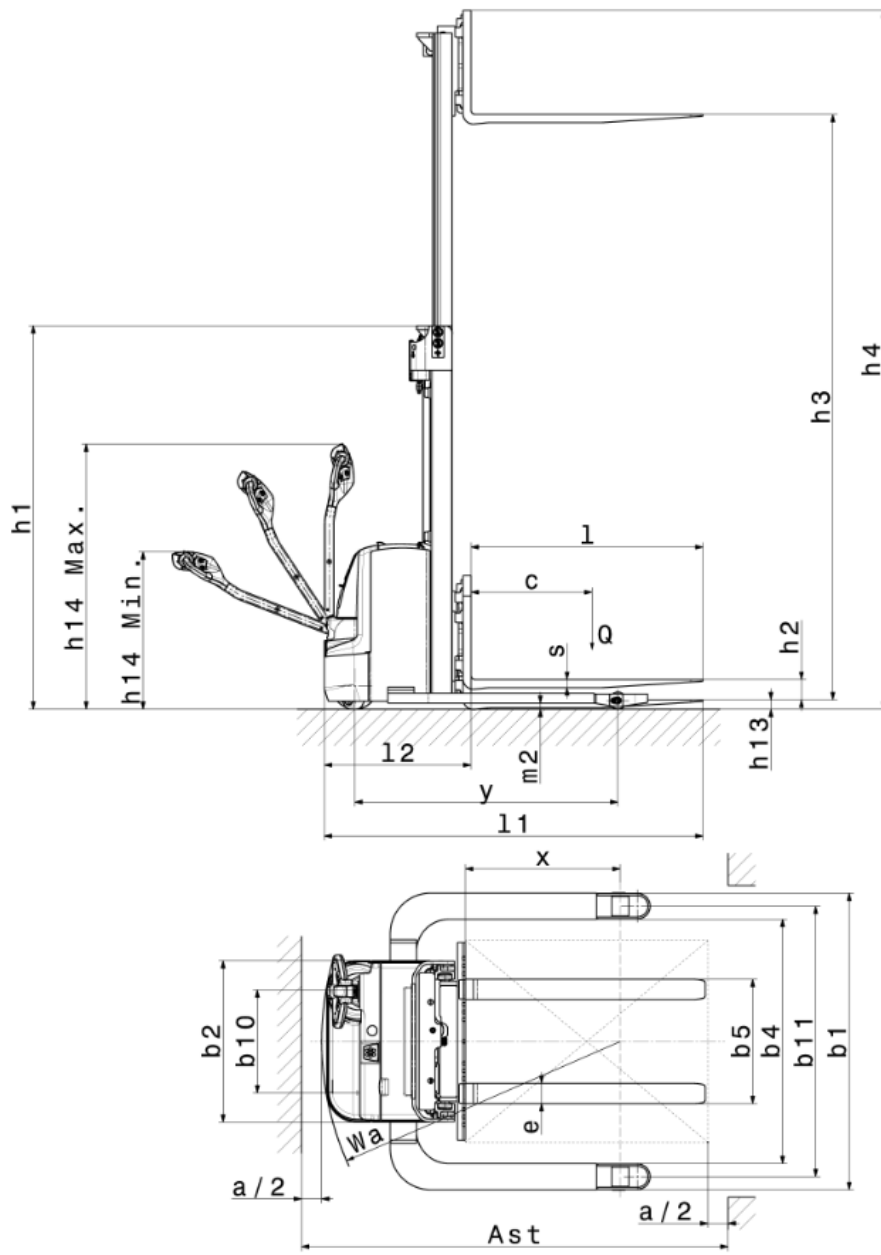

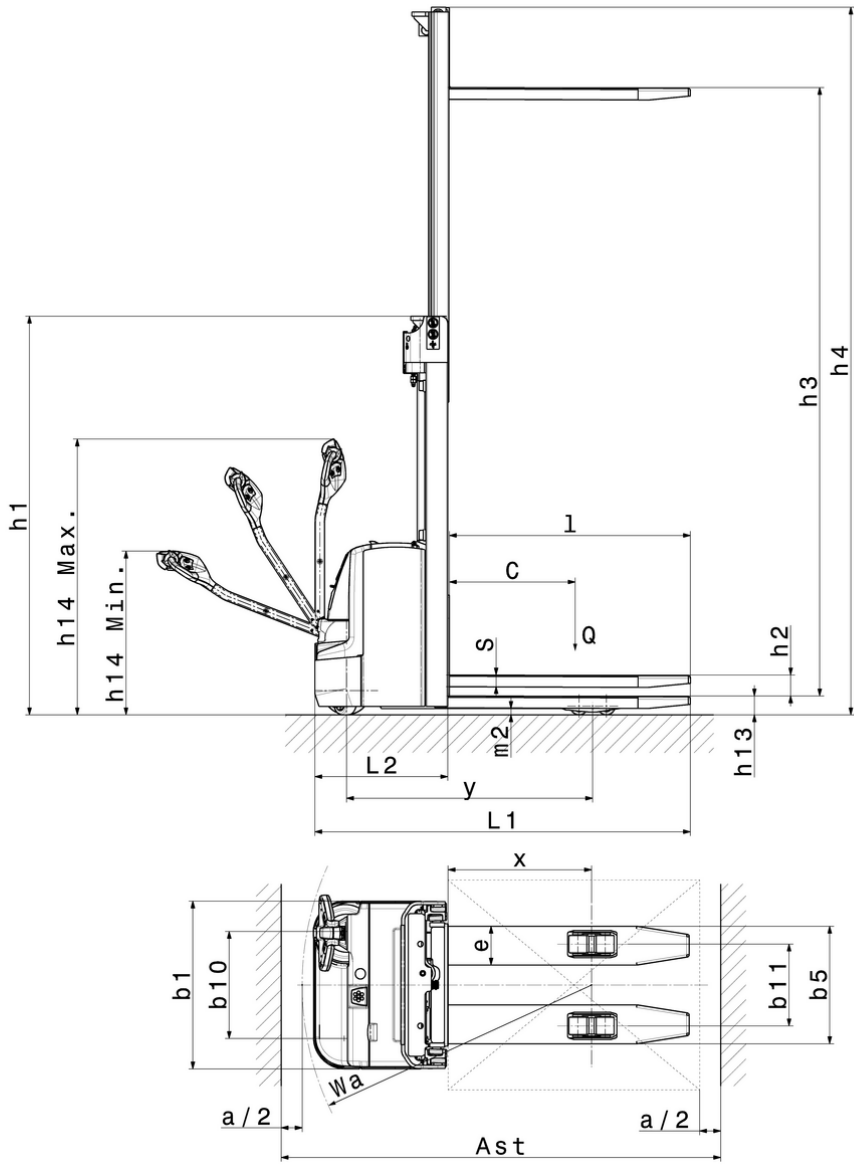

## EJC MA 112 + B12

EJC MA 112	Lift (h3)	Retracted mast height (h1)	Free lift (h2)	Extended mast height (h4)
Duplex mast ZT	2500 mm	1750 mm	100 mm	2973 mm
	2900 mm	1950 mm	100 mm	3373 mm
	3200 mm	2100 mm	100 mm	3673 mm
	3600 mm	2300 mm	100 mm	4073 mm
EJC MA B12	Lift (h3)	Retracted mast height (h1)	Free lift (h2)	Extended mast height (h4)
Duplex mast ZT	2440 mm	1750 mm	100 mm	3002 mm
	2840 mm	1950 mm	100 mm	3402 mm
	3140 mm	2100 mm	100 mm	3702 mm
	3540 mm	2300 mm	100 mm	4102 mm

## VDI table

Characteristic	1.1	Manufacturer (abbreviated description)		Jungheinrich	
	1.3	Drive		Electric	
	1.4	Operation		Pedestrian	
	1.5	Load capacity/load	Q kg	1200	
	1.6	Load centre distance	c mm	600	
	1.8	Load distance, centre of drive axle to fork	x mm	684	760
	1.9	Wheelbase	y mm	1174	1306
	Weights	2.1.1	Service weight (incl. battery)	kg	820
2.2		Axle load laden front/rear	kg	660 / 1360	827 / 1481
2.3		Axle load unladen front/rear	kg	575 / 245	682 / 281
Wheels/suspension system	3.1	Tyres		Polyurethane (PU)	
	3.2	Tyre size, front		Ø 230 x 70	
	3.3	Tyre size, rear		Ø 85 x 110 / Ø 85 x 85	Ø 85 x 100
	3.4	Additional wheels		Ø 140 x 54	
	3.5	Wheels, number front/back (x=driven)		1x +1/2 or 4	1x +1/2
	3.6	Tread width, front	b10 mm	510	
	3.7	Tread width, rear	b11 mm	390	1340
Basic dimensions	4.2	Retracted mast height (h1)	h1 mm	1950	
	4.3	Free lift (h2)	h2 mm	100	
	4.4	Lift (h3)	h3 mm	2900	2840
	4.5	Extended mast height (h4)	h4 mm	3373	3402
	4.9	Height of tiller handle in drive position min./max.	h14 mm	770 / 1310	
	4.15	Height, lowered	h13 mm	90	47
	4.19	total length	l1 mm	1791	1877
	4.20	Length including fork shank	l2 mm	634	727
	4.21.1	total width	b1 mm	800	1470
	4.21.2	total width	b2 mm	800	
	4.22	Fork dimensions	s/e/l mm	56 x 185 x 1150	40 x 100 x 1150
	4.24	Fork carriage width	b3 mm	-	980
	4.25	Width across forks	b5 mm	560	-
	4.26	Width between support arms/loading areas	b4 mm	245	1210
	4.32	Ground clearance centre of wheelbase	m2 mm	30	
	4.34.1	Aisle width (pallet 1000x1200 sideways)	Ast mm	2300	2326
4.34.2	Aisle width (pallet 800x1200 length)	Ast mm	2240	2270	
4.35	Turning radius	Wa mm	1380	1480	
Performance data	5.1	Travel speed laden/unladen	km/h	6 / 6	
	5.2	Lift speed laden/unladen	m/s	0.11 / 0.22	
	5.3	Lowering speed laden/unladen	m/s	0.43 / 0.4	
	5.7	Gradeability laden/unladen	%	8 / 16	
	5.10	Service brake		generative	

E-motor/Electronics	6.1	Drive motor, performance S2 60 min	kW	1	
	6.2	Lift motor, performance with S3	kW	2.2	
	6.3	Battery according to DIN 43531/35/36		no	
	6.4	Battery voltage/nominal capacity	V / Ah	24 / 160	
	6.5	Battery weight	kg	152	
	6.6.1	Energy consumption according to EN cycle	kWh/h	0.84	
	6.6.2	CO2 equivalent according to EN ISO 23308	kg/h0	0.4	
	6.7	Throughput	t/h	39	-
Other	8.1	Type of drive control		AC	
	10.7	Sound pressure level according to EN12053	dB (A)	65	

- This data sheet according to VDI guideline 2198 only states the technical values of the standard truck. Different tyres, other masts, additional equipment etc. may result in different values.

The German production facilities in  
Norderstedt, Moosburg and Landsberg are  
certified as well as our Genuine Parts  
Center in Kaltenkirchen.

ISO 9001  
ISO 14001

Jungheinrich fork lift trucks meet European  
safety requirements.



 **JUNGHEINRICH**

The logo features a red upward-pointing arrow integrated into the letter 'J' of the word 'JUNGHEINRICH', which is written in a bold, black, sans-serif font.