



Electric pedestrian stacker with support arm lift

ERD 120i

Lift height: 1500-2905 mm / Load capacity: 2000 kg



ERD 120i

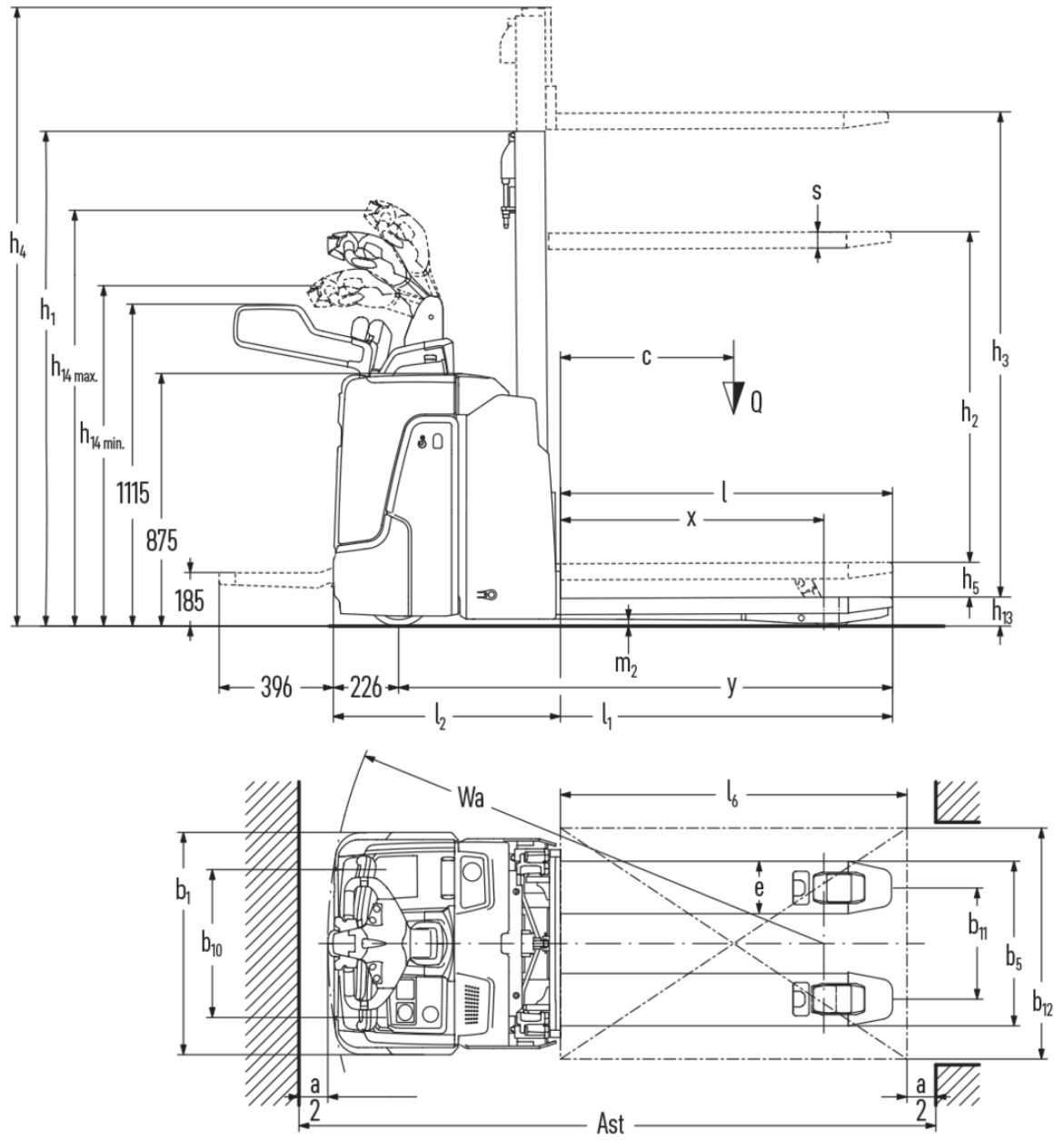

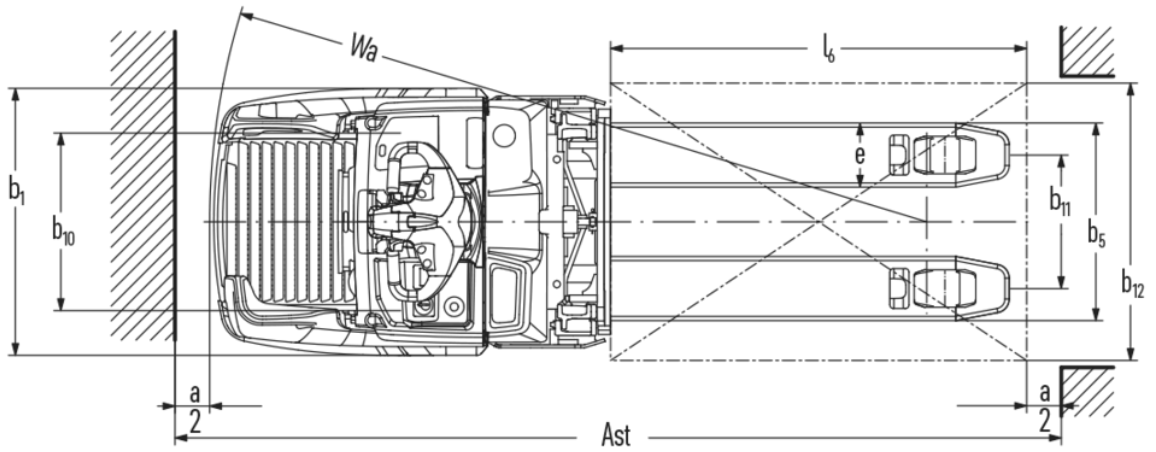

ERD 120i

ERD 120i	Lift (h3)	Retracted mast height (h1)	Free lift (h2)	Extended mast height (h4)
Duplex mast ZT	1660 mm	1306 mm	100 mm	2115 mm
	2010 mm	1481 mm	100 mm	2465 mm
	2100 mm	1526 mm	100 mm	2555 mm
	2560 mm	1756 mm	100 mm	3015 mm
	2900 mm	1926 mm	100 mm	3355 mm
Duplex mast ZZ	2500 mm	1706 mm	1250 mm	2956 mm
	2900 mm	1906 mm	1450 mm	3356 mm
Single mast E	1500 mm	1921 mm	1468 mm	1953 mm
	1660 mm	2081 mm	1628 mm	2113 mm
	2100 mm	2521 mm	2068 mm	2553 mm
Triplex mast DT	2050 mm	1213 mm	100 mm	2513 mm
	2350 mm	1313 mm	100 mm	2813 mm
	2500 mm	1363 mm	100 mm	2963 mm
	2905 mm	1498 mm	100 mm	3368 mm

VDI table

Characteristic	1.1	Manufacturer (abbreviated description)			Jungheinrich
	1.2	Manufacturer's type designation			ERD 120i
	1.3	Drive type			electric
	1.4	Operation			Pedestrian
	1.5	Load capacity/load	Q	kg	2000
	1.5.1	Rated capacity/load with mast lift	Q	kg	1000
	1.5.2	Rated capacity/load with support arm lift	Q	kg	2000
	1.6	Load centre distance	c	mm	600
	1.8	Load distance, centre of drive axle to fork	x	mm	910
	1.9	Wheelbase	y	mm	1469
Weights	2.1.1	Service weight (incl. battery)		kg	853
	2.2	Axle load laden front/rear		kg	1794 / 1059
	2.3	Axle load unladen front/rear		kg	216 / 637
Wheels/chassis	3.1	Tyres			Polyurethane (PU)
	3.2	Tyre size, front			Ø 230 x 80
	3.3	Tyre size, rear			Ø 85 x 95 / Ø 85 x 75
	3.4	Additional wheels			Ø 140 x 50
	3.5	Wheels, number front/back (x=driven)			1x +2/2 oder 4
	3.6	Tread width, front	b10	mm	512
	3.7	Tread width, rear	b11	mm	385
Basic dimensions	4.2	Retracted mast height (h1)	h1	mm	1306
	4.3	Free lift (h2)	h2	mm	1256
	4.4	Lift (h3)	h3	mm	1660
	4.5	Extended mast height (h4)	h4	mm	2115
	4.6	Initial lift	h5	mm	110
	4.9	Height of tiller handle in drive position min./max.	h14	mm	1137 / 1419
	4.15	Height, lowered	h13	mm	92
	4.19	Total length	l1	mm	1971
	4.20	Length including fork shank	l2	mm	784
	4.21.1	total width	b1	mm	770
	4.22	Fork dimensions	s/e/l	mm	56 x 185 x 1190
	4.25	Width across forks	b5	mm	570
	4.32	Ground clearance centre of wheelbase	m2	mm	19
	4.34.2	Aisle width (pallet 800x1200 length)	Ast	mm	2389
4.34.8	Aisle width (pallet 800x1200 crosswise)	Ast	mm	2502	
4.35	Turning radius	Wa	mm	1695	
Performance data	5.1	Travel speed laden/unladen		km/h	9 / 9
	5.2	Lift speed laden/unladen		m/s	0.21 / 0.39
	5.3	Lowering speed laden/unladen		m/s	0.48 / 0.37
	5.8	Max. gradeability laden/unladen		%	8 / 16
	5.10	Service brake			generative

Electric motor/electronics	6.1	Drive motor, performance S2 60 min	kW	2.8
	6.2	Lift motor, performance with S3	kW	2.2
	6.3	Battery according to DIN 43531/35/36		no
	6.4	Battery voltage/nominal capacity	V / Ah	25.6 / 100
	6.5	Battery weight	kg	35
	6.6.1	Energy consumption according to EN cycle	kWh/h	0.4
	6.6.2	CO2 equivalent according to EN ISO 23308	kg/h0	0.2
	6.7	Throughput	t/h	100
Other	8.1	Type of drive control		AC
	10.7	Sound pressure level according to EN12053	dB (A)	64
- This data sheet according to VDI guideline 2198 only states the technical values of the standard truck. Different tyres, other masts, additional equipment etc. may result in different values.				

The values in the table apply to the folding stand-on platform (folded up) with restraint system (optional), battery compartment XS, mast ZT1660, proportional hydraulics (optional), fork length 1,190 mm, raised support arm lift.

- VDI no. 1.5: in double-decker operation: mast lift max. 1 t / total load max. 2 t. Permitted up to a lift height $h_{13} + h_3$ of 1,800 mm. The heavier load is to be transported on the support arms (below).
- VDI no. 1.8: with lowered support arms: $x + 53$ mm. With fork length 1,150 mm: $x - 40$ mm. With simplex mast: $x - 1$ mm; triplex telescopic mast: $x - 10$ mm; ZZ mast: $x - 29$ mm.
- VDI no. 1.9: with lowered support arms: $y + 53$ mm. With fork length 1,150 mm: $y - 40$ mm. With S battery compartment: $y + 30$ mm.
- VDI no. 4.19: with S battery compartment: $l_1 + 30$ mm. With folding platform folded down: $l_1 + 396$ mm; compact, fixed platform: $l_1 + 360$ mm; extended, fixed platform: $l_1 + 474$ mm. With simplex mast: $l_1 + 1$ mm; triplex telescopic mast: $l_1 + 10$ mm; ZZ mast: $l_1 + 29$ mm.
- VDI no. 4.20: with S battery compartment: $l_2 + 30$ mm. With folding platform folded down: $l_2 + 396$ mm; compact, fixed platform: $l_2 + 360$ mm; extended, fixed platform: $l_2 + 474$ mm. With simplex mast: $l_2 + 1$ mm; triplex telescopic mast: $l_2 + 10$ mm; ZZ mast: $l_2 + 29$ mm.
- VDI no. 4.34.1: with lowered support arms: $AST + 47$ mm; with fork length 1,150 mm: aisle width - 40 mm. With S battery compartment: aisle width + 30 mm. With folding platform folded down: aisle width + 396 mm; compact, fixed platform: aisle width + 360 mm; extended, fixed platform: aisle width + 474 mm. With simplex mast: aisle width + 1 mm; triplex telescopic mast: aisle width + 10 mm; ZZ mast: aisle width + 29 mm.
- VDI no. 4.34.2: with lowered support arms: $AST + 47$ mm; with fork length 1,150 mm: aisle width - 40 mm. With S battery compartment: aisle width + 30 mm. With folding platform folded down: aisle width + 396 mm; compact, fixed platform: aisle width + 360 mm; extended, fixed platform: aisle width + 474 mm. With simplex mast: aisle width + 1 mm; triplex telescopic mast: aisle width + 10 mm; ZZ mast: aisle width + 29 mm.
- VDI no. 4.35: with lowered support arms: $AST + 53$ mm; with fork length 1,150 mm: $Wa - 40$ mm. With S battery compartment: $Wa + 30$ mm. With folding platform folded down: $Wa + 396$ mm; compact, fixed platform: $Wa + 360$ mm; extended, fixed platform: $Wa + 474$ mm.
- VDI no. 4.9: with fixed stand-on platform: 1,220 mm.
- VDI no. 5.1: maximum travel speed in double-decker operation (mast lift > 400 mm): 6 km/h.
- VDI no. 6.2: specified value with S3 = 10% power-on time.

The German production facilities in
Norderstedt, Moosburg and Landsberg are
certified as well as our Genuine Parts
Center in Kaltenkirchen.

ISO 9001
ISO 14001

Jungheinrich fork lift trucks meet European
safety requirements.



 **JUNGHEINRICH**