



## Electric pedestrian stacker with support arm lift

**EJD 120/222**

Lift height: 1500-2905 mm / Load capacity: 2000-2200 kg



# EJD 120/222

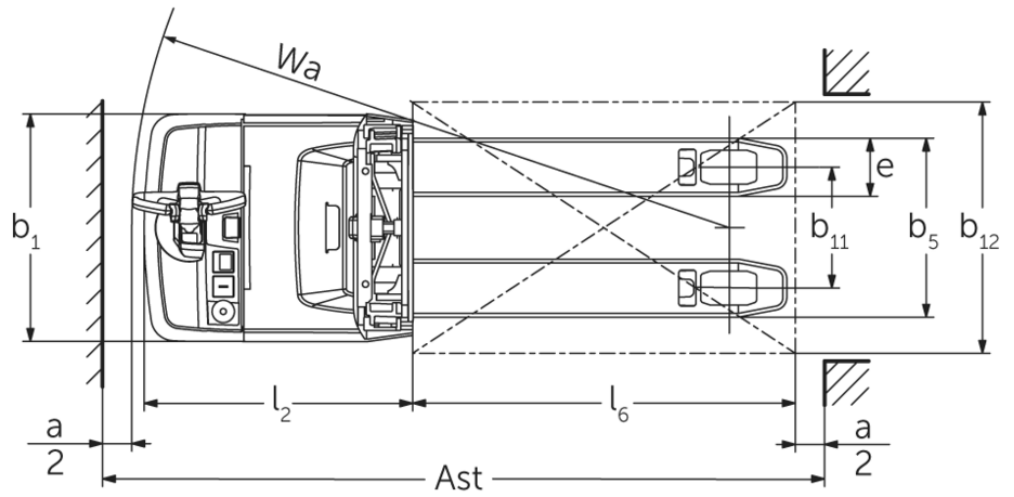

# EJD 120/222

EJD 120, EJD 222		Lift (h3)	Retracted mast height (h1)	Free lift (h2)	Extended mast height (h4)
Duplex mast ZT	1660 mm	1306 mm	100 mm	2115 mm	
	2010 mm	1481 mm	100 mm	2465 mm	
	2100 mm	1526 mm	100 mm	2555 mm	
Single mast E	1500 mm	1921 mm	1468 mm	1953 mm	
	1660 mm	2081 mm	1628 mm	2113 mm	
EJD 222		Lift (h3)	Retracted mast height (h1)	Free lift (h2)	Extended mast height (h4)
Duplex mast ZT	2560 mm	1756 mm	100 mm	3015 mm	
	2900 mm	1926 mm	100 mm	3355 mm	
Triplex mast DT	2050 mm	1213 mm	100 mm	2513 mm	
	2350 mm	1313 mm	100 mm	2813 mm	
	2500 mm	1363 mm	100 mm	2963 mm	
	2905 mm	1498 mm	100 mm	3368 mm	

## VDI table

					Jungheinrich	
					EJD 120	EJD 222
Characteristic	1.1	Manufacturer (abbreviated description)				
	1.2	Manufacturer's type designation				
	1.3	Drive type			electric	
	1.4	Operation			Pedestrian	
	1.5	Load capacity/load	Q	kg	2000	2200
	1.5.1	Rated capacity/load with mast lift	Q	kg	1000	
	1.5.2	Rated capacity/load with support arm lift	Q	kg	2000	2200
	1.6	Load centre distance	c	mm	600	
	1.8	Load distance, centre of drive axle to fork	x	mm	940	953
	1.9	Wheelbase	y	mm	1495	1664
Weights	2.1	Netto weight		kg	662	725
	2.1.1	Service weight (incl. battery)		kg	812	935
	2.2	Axle load laden front/rear		kg	1081 / 1738	1116 / 2024
	2.3	Axle load unladen front/rear		kg	585 / 227	664 / 271
Wheels/chassis	3.1	Tyres			Polyurethane (PU)	
	3.2	Tyre size, front			Ø 230 x 65	
	3.3	Tyre size, rear			Ø 85 x 95 / Ø 85 x 75	
	3.4	Additional wheels			Ø 100 x 40	
	3.5	Wheels, number front/back (x=driven)			1x +2/2 oder 4	
	3.6	Tread width, front	b10	mm	520	522
	3.7	Tread width, rear	b11	mm	350	385
Basic dimensions	4.2	Retracted mast height (h1)	h1	mm	1265	1306
	4.3	Free lift (h2)	h2	mm	90	100
	4.4	Lift (h3)	h3	mm	1660	
	4.5	Extended mast height (h4)	h4	mm	2116	2115
	4.6	Initial lift	h5	mm	120	
	4.9	Height of tiller handle in drive position min./max.	h14	mm	820 / 1237	750 / 1237
	4.15	Height, lowered	h13	mm	93	90
	4.19	Total length	l1	mm	1847	2046
	4.20	Length including fork shank	l2	mm	684	783
	4.21.1	total width	b1	mm	726	
	4.22	Fork dimensions	s/e/l	mm	56 x 185 x 1190	
	4.25	Width across forks	b5	mm	535	570
	4.32	Ground clearance centre of wheelbase	m2	mm	23	20
	4.34.1	Aisle width (pallet 1000x1200 sideways)	Ast	mm	2469	2578
4.34.2	Aisle width (pallet 800x1200 length)	Ast	mm	2343	2447	
4.35	Turning radius	Wa	mm	1666	1776	
Performance data	5.1	Travel speed laden/unladen		km/h	6 / 6	
	5.2	Lift speed laden/unladen		m/s	0.14 / 0.25	
	5.3	Lowering speed laden/unladen		m/s	0.31 / 0.25	
	5.8	Max. gradeability laden/unladen		%	8 / 15	10 / 15
	5.10	Service brake			generative	

Electric motor/electronics	6.1	Drive motor, performance S2 60 min	kW	1.1	1.7
	6.2	Lift motor, performance with S3	kW	2.2	
	6.3	Battery according to DIN 43531/35/36		DIN 43535 B	
	6.4	Battery voltage/nominal capacity	V / Ah	24 / 150	24 / 250
	6.5	Battery weight	kg	150	210
	6.6	Energy consumption according to VDI cycle	kWh/h	0	
	6.6.1	Energy consumption according to EN cycle	kWh/h	0.54	0.61
	6.6.2	CO2 equivalent according to EN ISO 23308	kg/h0	0.3	
	6.7	Throughput	t/h	41	37
	6.8	Turnover efficiency according to VDI 2198	t/kWh	49	39
	6.8.1	Energy consumption with max. throughput	kWh/h	0.84	-
Other	8.1	Type of drive control		AC	
	10.7	Sound pressure level according to EN12053	dB (A)	67	
- This data sheet according to VDI guideline 2198 only states the technical values of the standard truck. Different tyres, other masts, additional equipment etc. may result in different values.					

#### EJD 120:

The values in the table apply for the S-VBE battery compartment, ZT1660 mast, raised support arm lift.

- VDI no. 1.5: rated capacity in double-decker mode: support arm lift: 1.0 t / mast lift: 1.0 t.
- VDI no. 1.8: with lowered support arms:  $x + 56$  mm.
- VDI no. 1.9: with lowered support arms:  $y + 56$  mm; with M-VBE battery compartment:  $y + 74$  mm, M Li-ion  $y + 142$  mm.
- VDI no. 4.19: with M-VBE battery compartment:  $l1 \geq 74$  mm, M Li-ion:  $l1 + 142$  mm.
- VDI no. 4.20: with M-VBE battery compartment:  $l2 \geq 74$  mm, M Li-ion:  $l2 + 142$  mm.
- VDI no. 4.34.1: with lowered support arms: aisle width + 54 mm; with M-VBE battery compartment: aisle width + 74 mm; M Li-ion: aisle width + 142 mm.
- VDI no. 4.34.2: with lowered support arms: aisle width + 29 mm; with M-VBE battery compartment: aisle width + 74 mm; M Li-ion: aisle width + 142 mm.
- VDI no. 4.35: with lowered support arms:  $Wa + 56$  mm; with M-VBE battery compartment:  $Wa + 74$  mm; M Li-ion:  $Wa + 142$  mm.
- VDI no. 5.2: lift speed laden / unladen for support arm lift: 0.05 / 0.05 km/h.
- VDI no. 5.3: lowering speed laden / unladen for support arm lift: 0.03 / 0.05 km/h.
- VDI no. 6.2: specified value with S3 = 5% power-on time.

#### EJD 222:

The values in the table apply for the M-LBE battery compartment, ZT1660 mast, raised support arm lift.

- VDI no. 1.5: rated capacity in double-decker mode: support arm lift: 1.0 t / mast lift: 1.0 t.
- VDI no. 1.8: with lowered support arms:  $x + 56$  mm.
- VDI no. 1.9: with lowered support arms:  $y + 56$  mm; with M-VBE battery compartment:  $y + 72$  mm; with L-VBE battery compartment:  $y + 117$  mm.
- VDI no. 4.19: with M-VBE battery compartment:  $l1 + 72$  mm; with L-VBE battery compartment:  $l1 + 117$  mm.
- VDI no. 4.20: with M-VBE battery compartment:  $l2 + 72$  mm; with L-VBE battery compartment:  $l2 + 117$  mm.
- VDI no. 4.34.1: with lowered support arms: aisle width + 54 mm; with M-VBE battery compartment: aisle width + 72 mm; with L-VBE battery compartment: aisle width + 117 mm.
- VDI no. 4.34.2: with lowered support arms: aisle width + 29 mm; with M-VBE battery compartment: aisle width + 72 mm; with L-VBE battery compartment: aisle width + 117 mm.
- VDI no. 4.35: with lowered support arms:  $Wa + 56$  mm; with M-VBE battery compartment:  $Wa + 72$  mm; with L-VBE battery compartment:  $Wa + 117$  mm.
- VDI no. 5.2: lift speed laden / unladen for support arm lift: 0.05 / 0.05 km/h
- VDI no. 5.3: lowering speed laden / unladen for support arm lift: 0.025 / 0.05 km/h
- VDI no. 6.2: specified value with S3 = 5% power-on time.

The German production facilities in  
Norderstedt, Moosburg and Landsberg are  
certified as well as our Genuine Parts  
Center in Kaltenkirchen.

ISO 9001  
ISO 14001

Jungheinrich fork lift trucks meet European  
safety requirements.



 **JUNGHEINRICH**

The Jungheinrich logo, featuring a red upward-pointing arrow above the word 'JUNGHEINRICH' in a bold, black, sans-serif font.