



Electric reach truck

ETV MB 214/216

Lift height: 5000-10700 mm / Load capacity: 1400-1600 kg



ETV MB 214/216

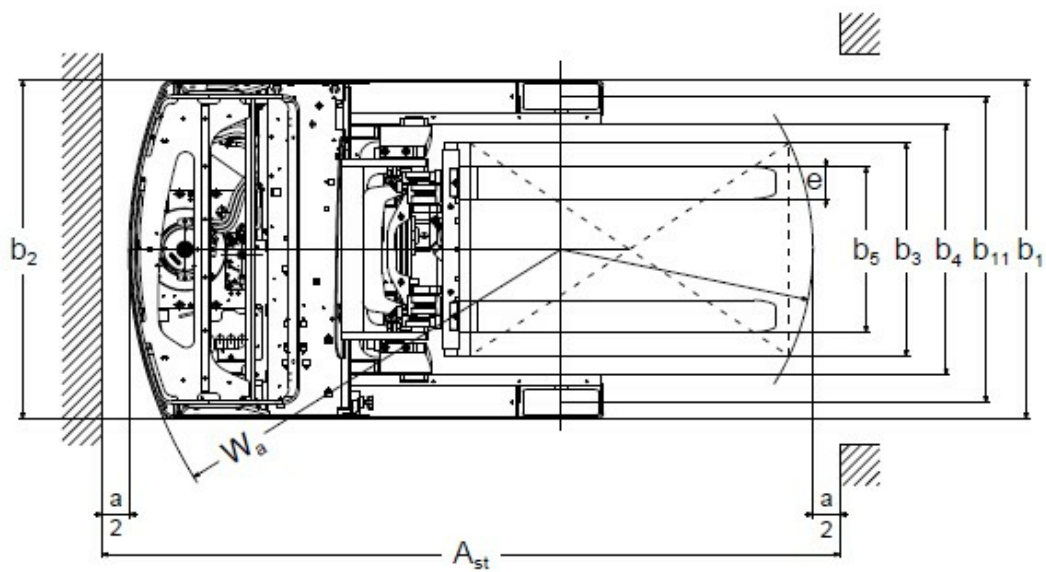
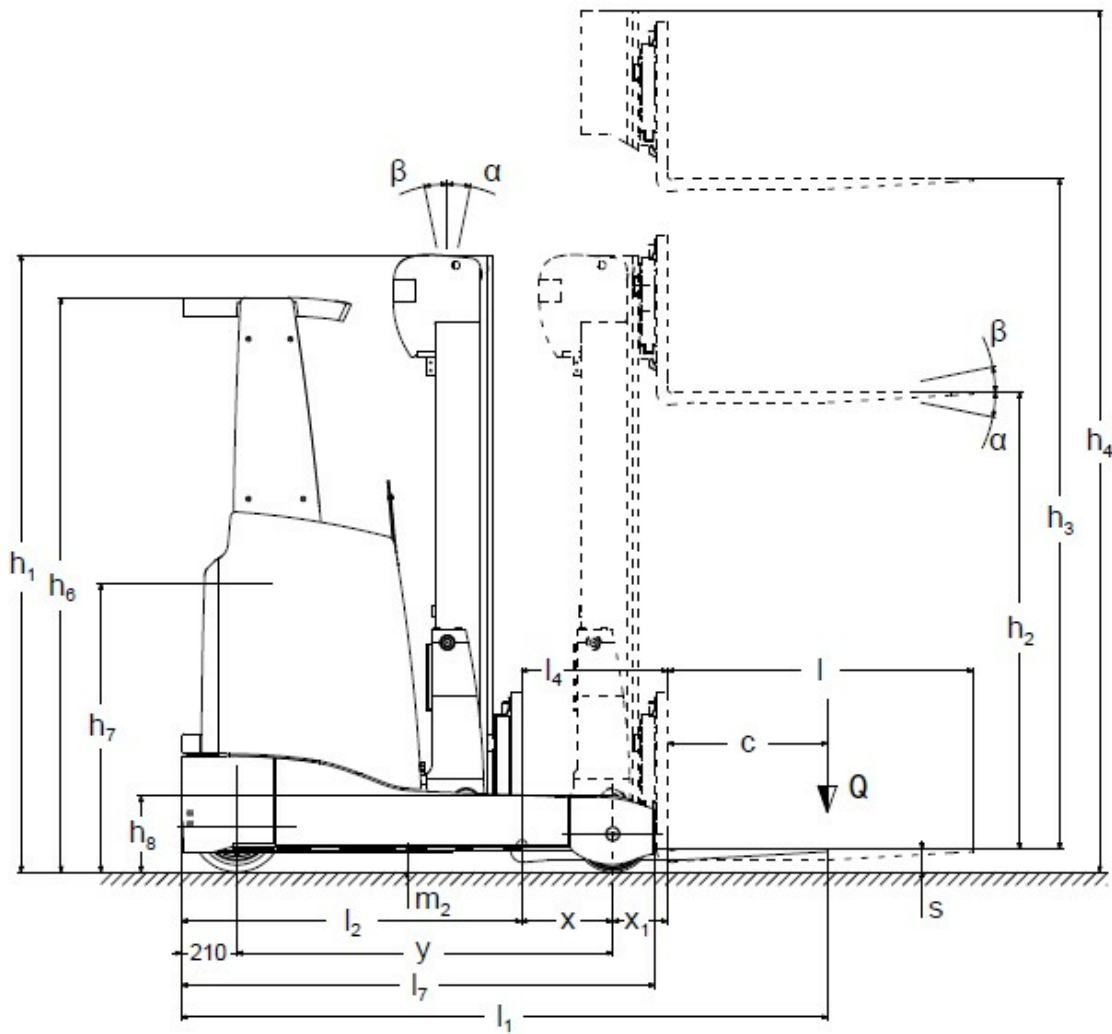

VDI table

- VDI no. 1.8: battery size and mast type affect load distance x
- VDI no. 2.1.1: battery size and mast version affect service weight and axle loads
- VDI no. 2.3: battery size and mast version affect service weight and axle loads
- VDI no. 2.4: battery size and mast version affect service weight and axle loads
- VDI no. 2.5: battery size and mast version affect service weight and axle loads
- VDI no. 4.1: the mast version determines the tilt values
- VDI no. 4.10: the height of the support arms is enlarged by 42 mm with a load support arm cover
- VDI no. 4.19: battery size, mast type and fork length affect the overall length l1
- VDI no. 4.19: total length increased by 20mm with floor stripes option
- VDI no. 4.20: battery size and mast type affect the length including fork shank l2
- VDI no. 4.28: battery size and mast type affect the reach distance l4
- VDI no. 4.34.1: battery size and mast type affect the aisle widths
- VDI no. 4.34.1: AST increased by 20mm with floor stripes option
- VDI no. 4.34.2: battery size and mast type affect the aisle widths
- VDI no. 4.34.2: AST increased by 20mm with floor stripes option
- VDI no. 4.7: height of overhead guard increased by 108mm with floor stripes option
- VDI no. 6.6.1: PLUS refers to the drive&liftPLUS performance package
- VDI no. 6.6.2: PLUS refers to the drive&liftPLUS performance package
- VDI no. 6.7: PLUS refers to the drive&liftPLUS performance package
- VDI no. 6.8.1: PLUS refers to the drive&liftPLUS performance package

The German production facilities in
Norderstedt, Moosburg and Landsberg are
certified as well as our Genuine Parts
Center in Kaltenkirchen.

ISO 9001
ISO 14001

Jungheinrich fork lift trucks meet European
safety requirements.



 **JUNGHEINRICH**

The Jungheinrich logo, featuring a red upward-pointing arrow above the word 'JUNGHEINRICH' in a bold, black, sans-serif font.